

# Thread Turning Inserts

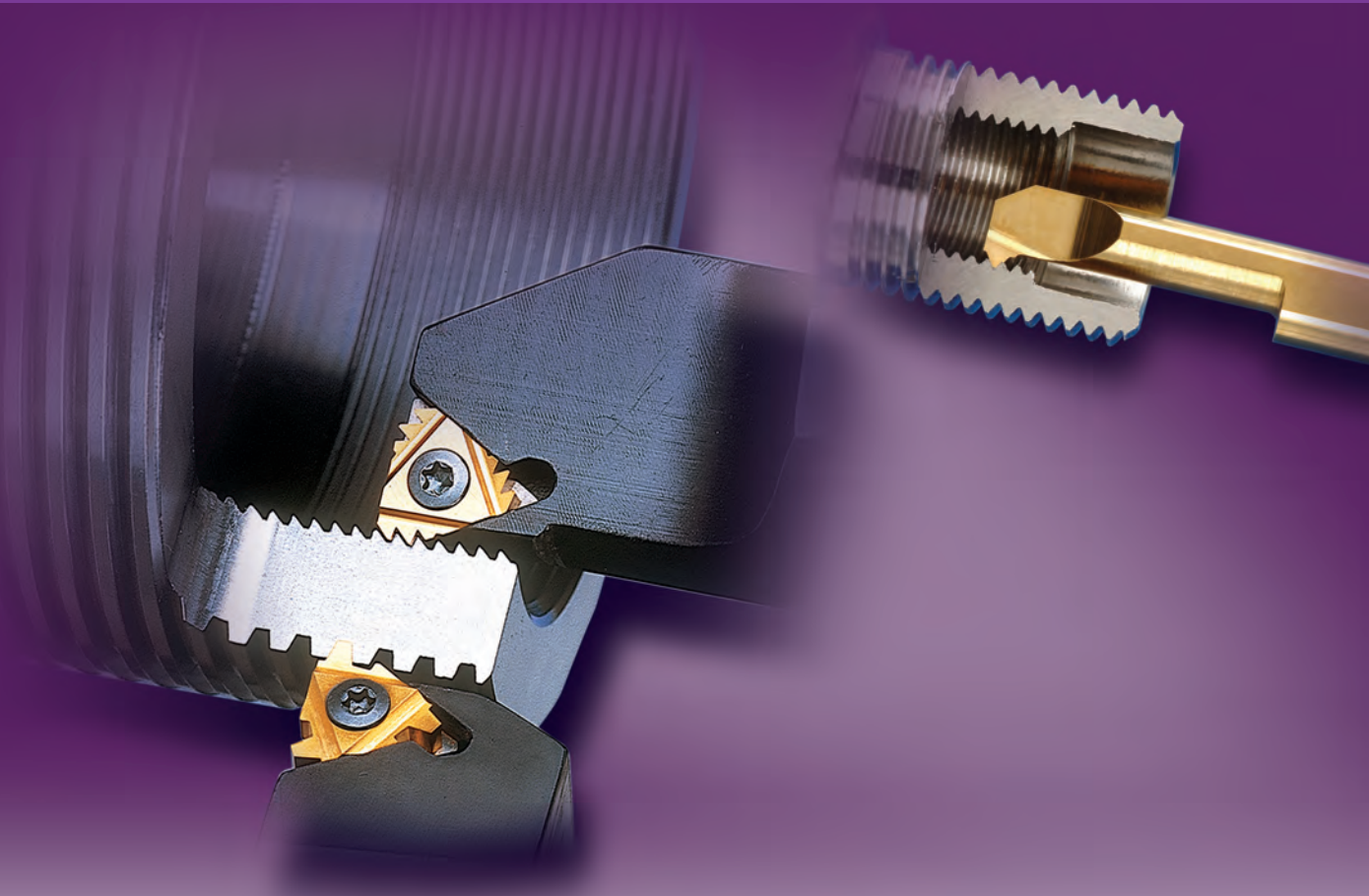

## BLU Grade

A sub-micrograin grade with PVD triple layer coating. The BLU grade provides a combination of very high strength with high wear resistance.

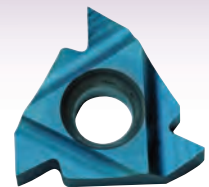

## HBA Grade

An extra-fine sub-micron grade with high toughness, for optimized performance on Hardened Steels and Cast Iron up to 62HRC, Titanium Alloys and Super Alloys (Hastelloy, Inconel, and Nickel based alloys).

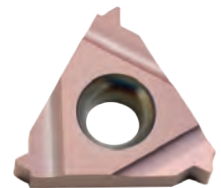

### Contents:

Page:

### Contents:

Page:

Product Identification	4	Stub Acme	26
Partial Profile 60°	5-6	Trapez - DIN 103	27
Partial Profile 55°	7-8	PG - DIN 40430	28
ISO - metric	9-11	Sägengewinde - DIN 513	28
UN - unified	12-15	Round - DIN 405	29
Whitworth 55°	16-19	Round - DIN 20400	29
NPT	20-21	UNJ	30-31
NPTF	22	MJ - ISO 5855	32
BSPT	23-24	American Buttress	33
DIN 477	24	Oil Threads	34-36
Acme	25	VAM	36

## Product Identification

### Thread Turning Inserts Ordering Codes

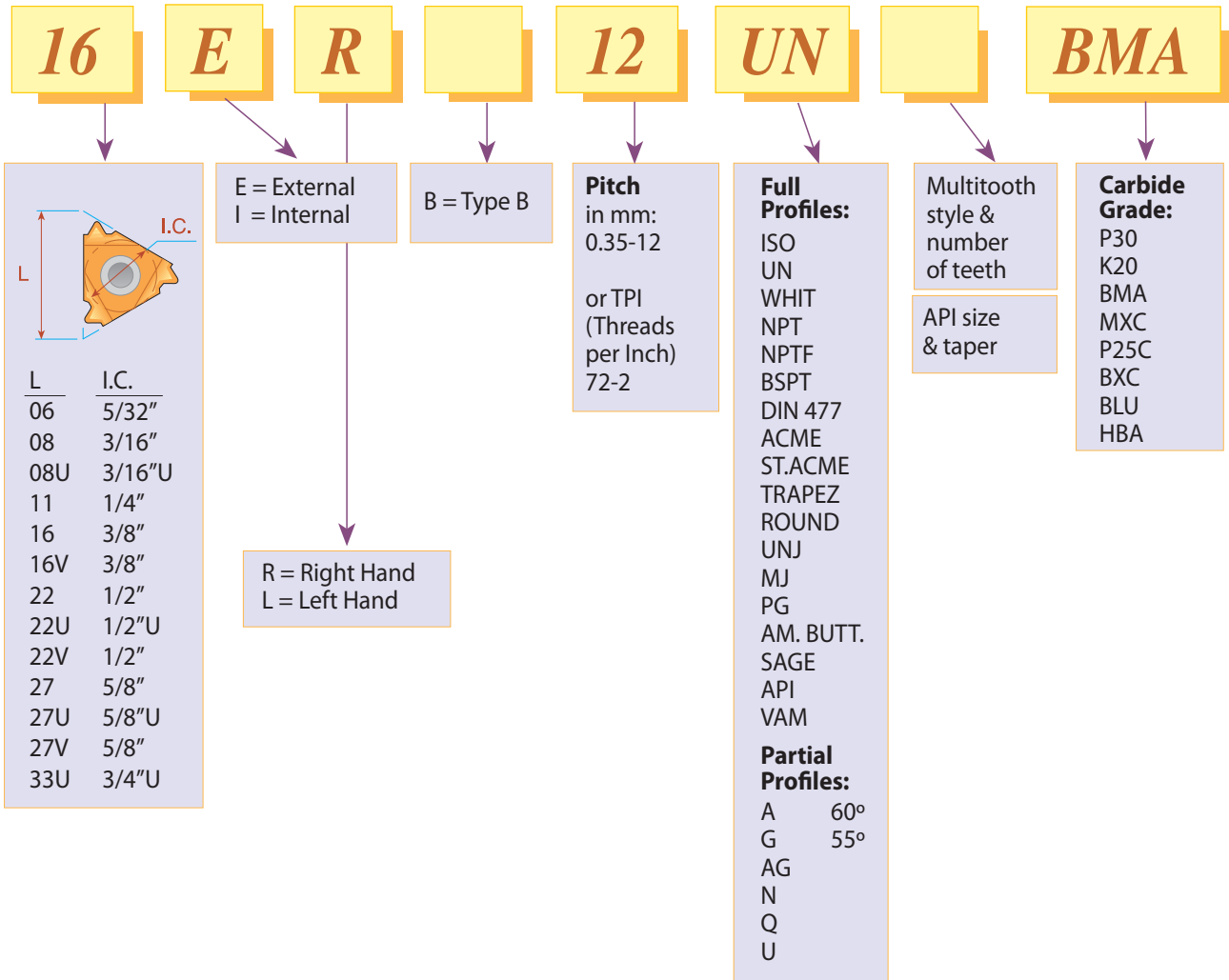

## Partial Profile 60°

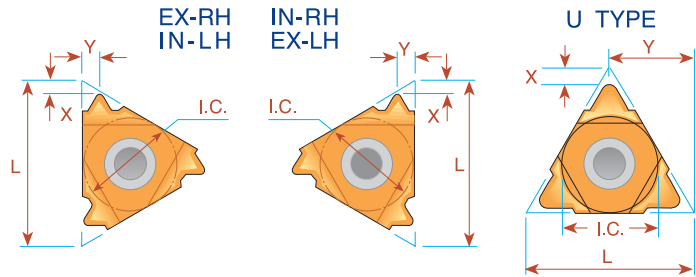
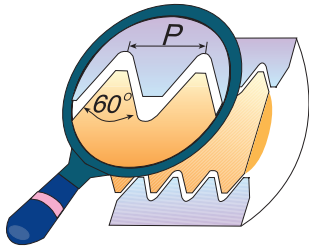

L	I.C. in	Pitch Range		<b>EXTERNAL</b>		<b>INTERNAL</b>		X	Y
		mm	TPI	Ordering Code Right Hand	Ordering Code Left Hand	Ordering Code Right Hand	Ordering Code Left Hand		
6	5/32	0.5 -1.25	48-20	<i>ULTRA MINIATURE</i> →		<b>*06 IR A60</b>	<b>*06 IL A60</b>	0.6	0.6
8	3/16	0.5 -1.5	48-16	<i>MINIATURE</i> →		<b>*08 IR A60</b>	<b>*08 IL A60</b>	0.6	0.7
8U	3/16U	1.75-2.0	14-11	<i>"U" MINIATURE</i> →		<b>*08U IR/L U60</b>		0.8	4.0
11	1/4	0.5 -1.5	48-16	<b>11 ER A60</b>	<b>11 EL A60</b>	<b>11 IR A60</b>	<b>11 IL A60</b>	0.8	0.9
16	3/8	0.5 -1.5	48-16	<b>16 ER A60</b>	<b>16 EL A60</b>	<b>16 IR A60</b>	<b>16 IL A60</b>	0.8	0.9
16	3/8	1.75-3.0	14- 8	<b>16 ER G60</b>	<b>16 EL G60</b>	<b>16 IR G60</b>	<b>16 IL G60</b>	1.2	1.7
16	3/8	0.5 -3.0	48- 8	<b>16 ER AG60</b>	<b>16 EL AG60</b>	<b>16 IR AG60</b>	<b>16 IL AG60</b>	1.2	1.7
22	1/2	3.5 -5.0	7- 5	<b>22 ER N60</b>	<b>22 EL N60</b>	<b>22 IR N60</b>	<b>22 IL N60</b>	1.7	2.5
22U	1/2U	5.5 -8.0	4.5- 3.25	<b>22U E/R/L U60</b>				0.6	11.0
27	5/8	5.5 -6.0	4.5- 4	<b>27 ER Q60</b>	<b>27 EL Q60</b>	<b>27 IR Q60</b>	<b>27 IL Q60</b>	2.1	3.1
27U	5/8U	6.5 -9.0	4- 2.75	<b>27U E/R/L U60</b>				1.0	13.7

Order example: 16 ER G60 MXC

For small bore threading see page 82  
\* Available only in BXC and BMA grades

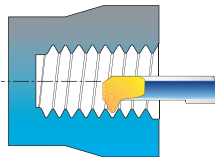

## Type B Ground Profile with Sintered Chip-breaker



L	I.C. in	Pitch Range		<b>EXTERNAL</b>		<b>INTERNAL</b>		X	Y
		mm	TPI	Ordering Code Right Hand	Ordering Code Left Hand	Ordering Code Right Hand	Ordering Code Left Hand		
16	3/8	0.5 -1.5	48-16	<b>16 ER B A60</b>		<b>16 IR B A60</b>		0.8	0.9
16	3/8	1.75-3.0	14- 8	<b>16 ER B G60</b>		<b>16 IR B G60</b>		1.2	1.7
16	3/8	0.5 -3.0	48- 8	<b>16 ER B AG60</b>		<b>16 IR B AG60</b>		1.2	1.7

Order example: 16 ER B G60 BMA

For Carbide Grade and Cutting Speed see page 60-61

## Partial Profile 60° Vertical

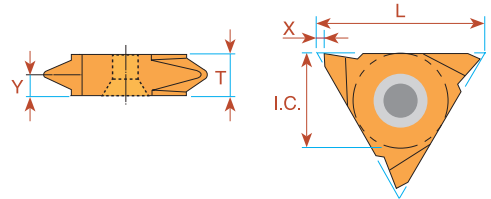

L	I.C. in	Pitch Range		<b>EXTERNAL</b> Ordering Code		<b>INTERNAL</b> Ordering Code		X	Y	T
		mm	TPI	Right Hand	Left Hand	Right Hand	Left Hand			
16	3/8	0.5 - 1.5	48-16	<b>16V ER A60</b>	<b>16V EL A60</b>			1.0	0.9	3.6
16	3/8	1.75- 3.0	14- 8	<b>16V ER G60</b>	<b>16V EL G60</b>			1.0	1.8	3.6
16	3/8	0.5 - 3.0	48- 8	<b>16V ER AG60</b>	<b>16V EL AG60</b>			1.0	1.8	3.6
22	1/2	1.75- 3.0	14- 8	<b>22V ER G60</b>	<b>22V EL G60</b>			1.2	1.7	4.0
22	1/2	0.5 - 5.0	7- 5	<b>22V ER N60</b>	<b>22V EL N60</b>			1.2	2.5	4.8
27	5/8	6.0 -10.0	4- 2.5	<b>27V ER V60</b>	<b>27V EL V60</b>	<b>27V IR V60</b>	<b>27V IL V60</b>	1.8	5.2	10.4

Order example: 16V ER G60 BMA

For Carbide Grade and Cutting Speed see page 60-61

## Partial Profile 55°

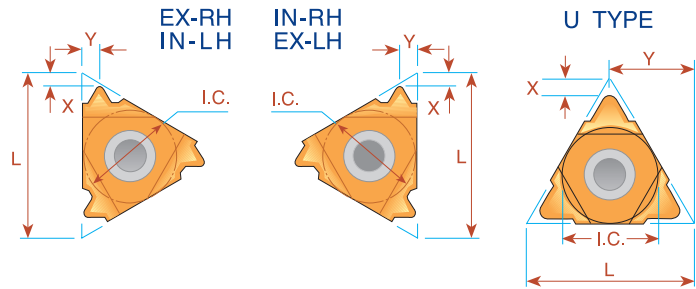
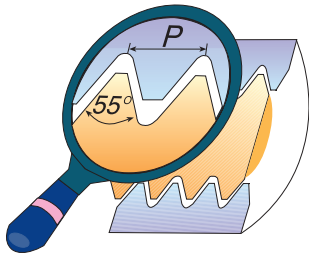

L	I.C. in	Pitch Range		<b>EXTERNAL</b>		<b>INTERNAL</b>		X	Y
		mm	TPI	Ordering Code Right Hand	Ordering Code Left Hand	Ordering Code Right Hand	Ordering Code Left Hand		
6	5/32	0.5 -1.25	48-20	<i>ULTRA MINIATURE</i> →		<b>*06 IR A55</b>	<b>*06 IL A55</b>	0.5	0.6
8	3/16	0.5 -1.5	48-16	<i>MINIATURE</i> →		<b>*08 IR A55</b>	<b>*08 IL A55</b>	0.6	0.7
8U	3/16U	1.75-2.0	14-11	<i>"U" MINIATURE</i> →		<b>*08U IR/L U55</b>		0.9	4.0
11	1/4	0.5 -1.5	48-16	<b>11 ER A55</b>	<b>11 EL A55</b>	<b>11 IR A55</b>	<b>11 IL A55</b>	0.8	0.9
16	3/8	0.5 -1.5	48-16	<b>16 ER A55</b>	<b>16 EL A55</b>	<b>16 IR A55</b>	<b>16 IL A55</b>	0.8	0.9
16	3/8	1.75-3.0	14- 8	<b>16 ER G55</b>	<b>16 EL G55</b>	<b>16 IR G55</b>	<b>16 IL G55</b>	1.2	1.7
16	3/8	0.5 -3.0	48- 8	<b>16 ER AG55</b>	<b>16 EL AG55</b>	<b>16 IR AG55</b>	<b>16 IL AG55</b>	1.2	1.7
22	1/2	3.5 -5.0	7- 5	<b>22 ER N55</b>	<b>22 EL N55</b>	<b>22 IR N55</b>	<b>22 IL N55</b>	1.7	2.5
22U	1/2U	5.5 -8.0	4.5- 3.25	<b>22U E/R/L U55</b>				0.9	11.0
27	5/8	5.5 -6.0	4.5- 4	<b>27 ER Q55</b>	<b>27 EL Q55</b>	<b>27 IR Q55</b>	<b>27 IL Q55</b>	2.0	2.9
27U	5/8U	6.5 -9.0	4 - 2.75	<b>27U E/R/L U55</b>				1.2	13.7

Order example: 16 ER G55 MXC

For small bore threading see page 82  
\* Available only in BXC and BMA grades

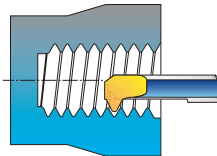

## Type B Ground Profile with Sintered Chip-breaker



L	I.C. in	Pitch Range		<b>EXTERNAL</b>		<b>INTERNAL</b>		X	Y
		mm	TPI	Ordering Code Right Hand	Ordering Code Right Hand	Ordering Code Right Hand	Ordering Code Right Hand		
16	3/8	1.75-3.0	14-8	<b>16 ER B G55</b>		<b>16 IR B G55</b>		1.2	1.7
16	3/8	0.5-3.0	48-8	<b>16 ER B AG55</b>		<b>16 IR B AG55</b>		1.2	1.7

Order example: 16 ER B G55 BMA

For Carbide Grade and Cutting Speed see page 60-61

## Partial Profile 55° Vertical

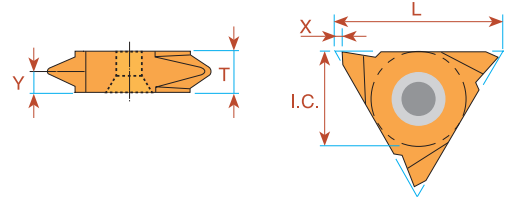

L	I.C. in	Pitch Range		<b>EXTERNAL</b> Ordering Code		<b>INTERNAL</b> Ordering Code		X	Y	T
		mm	TPI	Right Hand	Left Hand	Right Hand	Left Hand			
16	3/8	0.5 - 1.5	48-16	<b>16V ER A55</b>	<b>16V EL A55</b>			1.0	0.9	3.6
16	3/8	1.75- 3.0	14- 8	<b>16V ER G55</b>	<b>16V EL G55</b>			1.0	1.7	3.6
16	3/8	0.5 - 3.0	48- 8	<b>16V ER AG55</b>	<b>16V EL AG55</b>			1.0	1.8	3.6
22	1/2	3.5 - 5.0	7- 5	<b>22V ER N55</b>	<b>22V EL N55</b>			1.2	2.5	4.8
27	5/8	6.0-10.0	4- 2.5	<b>27V ER V55</b>	<b>27V EL V55</b>	<b>27V IR V55</b>	<b>27V IL V55</b>	1.8	5.2	10.4

Order example: 22V ER N55 BMA

For Carbide Grade and Cutting Speed see page 60-61

# Thread Turning Inserts

## ISO - metric

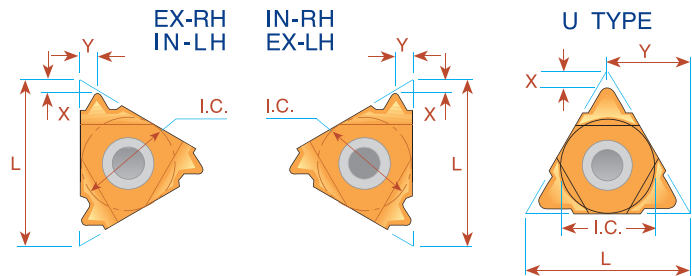
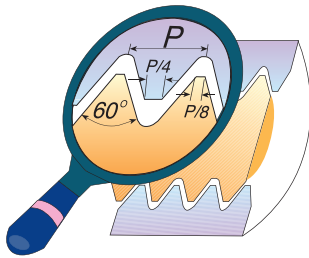

Pitch mm	L	I.C. in	EXTERNAL				INTERNAL			
			Ordering Code		X	Y	Ordering Code		X	Y
Right Hand	Left Hand	Right Hand	Left Hand	Right Hand			Left Hand			
0.5	6	5/32	<i>ULTRA MINIATURE</i> →				*06 IR 0.5 ISO	*06 IL 0.5 ISO	0.9	0.5
0.75	6	5/32					*06 IR 0.75 ISO	*06 IL 0.75 ISO	0.8	0.5
1.0	6	5/32					*06 IR 1.0 ISO	*06 IL 1.0 ISO	0.7	0.6
1.25	6	5/32					*06 IR 1.25 ISO	*06 IL 1.25 ISO	0.6	0.6
0.5	8	3/16	<i>MINIATURE</i> →				*08 IR 0.5 ISO	*08 IL 0.5 ISO	0.6	0.5
0.75	8	3/16					*08 IR 0.75 ISO	*08 IL 0.75 ISO	0.6	0.5
1.0	8	3/16					*08 IR 1.0 ISO	*08 IL 1.0 ISO	0.6	0.6
1.25	8	3/16					*08 IR 1.25 ISO	*08 IL 1.25 ISO	0.6	0.7
1.5	8	3/16					*08 IR 1.5 ISO	*08 IL 1.5 ISO	0.6	0.7
1.75	8	3/16					*08 IR 1.75 ISO	*08 IL 1.75 ISO	0.6	0.8
2.0	8U	3/16U	<i>"U" MINIATURE</i> →				*08U IR/L 2.0 ISO		0.9	4.0
0.35	11	1/4	11 ER 0.35 ISO	11 EL 0.35 ISO	0.8	0.4	11 IR 0.35 ISO	11 IL 0.35 ISO	0.8	0.3
0.4	11	1/4	11 ER 0.4 ISO	11 EL 0.4 ISO	0.7	0.4	11 IR 0.4 ISO	11 IL 0.4 ISO	0.8	0.4
0.45	11	1/4	11 ER 0.45 ISO	11 EL 0.45 ISO	0.7	0.4	11 IR 0.45 ISO	11 IL 0.45 ISO	0.8	0.4
0.5	11	1/4	11 ER 0.5 ISO	11 EL 0.5 ISO	0.6	0.6	11 IR 0.5 ISO	11 IL 0.5 ISO	0.6	0.6
0.6	11	1/4	11 ER 0.6 ISO	11 EL 0.6 ISO	0.6	0.6	11 IR 0.6 ISO	11 IL 0.6 ISO	0.6	0.6
0.7	11	1/4	11 ER 0.7 ISO	11 EL 0.7 ISO	0.6	0.6	11 IR 0.7 ISO	11 IL 0.7 ISO	0.6	0.6
0.75	11	1/4	11 ER 0.75 ISO	11 EL 0.75 ISO	0.6	0.6	11 IR 0.75 ISO	11 IL 0.75 ISO	0.6	0.6
0.8	11	1/4	11 ER 0.8 ISO	11 EL 0.8 ISO	0.6	0.6	11 IR 0.8 ISO	11 IL 0.8 ISO	0.6	0.6
1.0	11	1/4	11 ER 1.0 ISO	11 EL 1.0 ISO	0.7	0.7	11 IR 1.0 ISO	11 IL 1.0 ISO	0.6	0.7
1.25	11	1/4	11 ER 1.25 ISO	11 EL 1.25 ISO	0.8	0.9	11 IR 1.25 ISO	11 IL 1.25 ISO	0.8	0.8
1.5	11	1/4	11 ER 1.5 ISO	11 EL 1.5 ISO	0.8	1.0	11 IR 1.5 ISO	11 IL 1.5 ISO	0.8	1.0
1.75	11	1/4	11 ER 1.75 ISO	11 EL 1.75 ISO	0.8	1.1	11 IR 1.75 ISO	11 IL 1.75 ISO	0.8	1.1
2.0	11	1/4	11 ER 2.0 ISO	11 EL 2.0 ISO	0.8	1.1	11 IR 2.0 ISO	11 IL 2.0 ISO	0.8	0.9
2.5	11	1/4					11 IR 2.5 ISO	11 IL 2.5 ISO	0.8	1.2
0.35	16	3/8	16 ER 0.35 ISO	16 EL 0.35 ISO	0.8	0.4	16 IR 0.35 ISO	16 IL 0.35 ISO	0.8	0.3
0.4	16	3/8	16 ER 0.4 ISO	16 EL 0.4 ISO	0.7	0.4	16 IR 0.4 ISO	16 IL 0.4 ISO	0.8	0.4
0.45	16	3/8	16 ER 0.45 ISO	16 EL 0.45 ISO	0.7	0.4	16 IR 0.45 ISO	16 IL 0.45 ISO	0.8	0.4
0.5	16	3/8	16 ER 0.5 ISO	16 EL 0.5 ISO	0.6	0.6	16 IR 0.5 ISO	16 IL 0.5 ISO	0.6	0.6
0.6	16	3/8	16 ER 0.6 ISO	16 EL 0.6 ISO	0.6	0.6	16 IR 0.6 ISO	16 IL 0.6 ISO	0.6	0.6
0.7	16	3/8	16 ER 0.7 ISO	16 EL 0.7 ISO	0.6	0.6	16 IR 0.7 ISO	16 IL 0.7 ISO	0.6	0.6
0.75	16	3/8	16 ER 0.75 ISO	16 EL 0.75 ISO	0.6	0.6	16 IR 0.75 ISO	16 IL 0.75 ISO	0.6	0.6
0.8	16	3/8	16 ER 0.8 ISO	16 EL 0.8 ISO	0.6	0.6	16 IR 0.8 ISO	16 IL 0.8 ISO	0.6	0.6
1.0	16	3/8	16 ER 1.0 ISO	16 EL 1.0 ISO	0.7	0.7	16 IR 1.0 ISO	16 IL 1.0 ISO	0.6	0.7
1.25	16	3/8	16 ER 1.25 ISO	16 EL 1.25 ISO	0.8	0.9	16 IR 1.25 ISO	16 IL 1.25 ISO	0.8	0.9
1.5	16	3/8	16 ER 1.5 ISO	16 EL 1.5 ISO	0.8	1.0	16 IR 1.5 ISO	16 IL 1.5 ISO	0.8	1.0
1.75	16	3/8	16 ER 1.75 ISO	16 EL 1.75 ISO	0.9	1.2	16 IR 1.75 ISO	16 IL 1.75 ISO	0.9	1.2
2.0	16	3/8	16 ER 2.0 ISO	16 EL 2.0 ISO	1.0	1.3	16 IR 2.0 ISO	16 IL 2.0 ISO	1.0	1.3
2.5	16	3/8	16 ER 2.5 ISO	16 EL 2.5 ISO	1.1	1.5	16 IR 2.5 ISO	16 IL 2.5 ISO	1.1	1.5
3.0	16	3/8	16 ER 3.0 ISO	16 EL 3.0 ISO	1.2	1.6	16 IR 3.0 ISO	16 IL 3.0 ISO	1.1	1.5
3.5	16	3/8	16 ER 3.5 ISO	16 EL 3.5 ISO	1.2	1.7	16 IR 3.5 ISO	16 IL 3.5 ISO	1.2	1.7

\* Available only in BXC and BMA grades



## ISO - metric

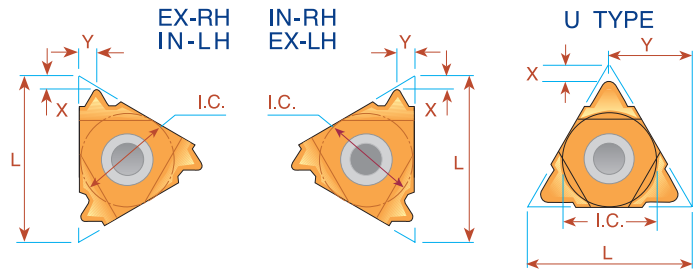
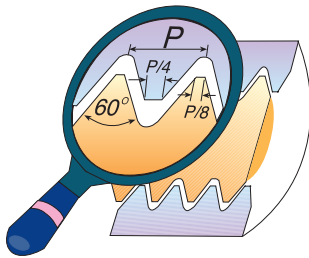

Pitch mm	L	I.C. in	<b>EXTERNAL</b>		X	Y	<b>INTERNAL</b>		X	Y
			Ordering Code Right Hand	Ordering Code Left Hand			Ordering Code Right Hand	Ordering Code Left Hand		
3.5	22	1/2	<b>22 ER 3.5 ISO</b>	<b>22 EL 3.5 ISO</b>	1.6	2.3	<b>22 IR 3.5 ISO</b>	<b>22 IL 3.5 ISO</b>	1.6	2.3
4.0	22	1/2	<b>22 ER 4.0 ISO</b>	<b>22 EL 4.0 ISO</b>	1.6	2.3	<b>22 IR 4.0 ISO</b>	<b>22 IL 4.0 ISO</b>	1.6	2.3
4.5	22	1/2	<b>22 ER 4.5 ISO</b>	<b>22 EL 4.5 ISO</b>	1.7	2.4	<b>22 IR 4.5 ISO</b>	<b>22 IL 4.5 ISO</b>	1.6	2.4
5.0	22	1/2	<b>22 ER 5.0 ISO</b>	<b>22 EL 5.0 ISO</b>	1.7	2.5	<b>22 IR 5.0 ISO</b>	<b>22 IL 5.0 ISO</b>	1.6	2.3
5.5	22	1/2	<b>22 ER 5.5 ISO</b>	<b>22 EL 5.5 ISO</b>	1.7	2.6	<b>22 IR 5.5 ISO</b>	<b>22 IL 5.5 ISO</b>	1.6	2.3
6.0	22	1/2	<b>**22 ER 6.0 ISO</b>	<b>**22 EL 6.0 ISO</b>	1.9	2.7	<b>22 IR 6.0 ISO</b>	<b>22 IL 6.0 ISO</b>	1.6	2.4
5.5	22U	1/2U	<b>22U ER/L 5.5 ISO</b>		2.3	11.0	<b>22U IR/L 5.5 ISO</b>		2.4	11.0
6.0	22U	1/2U	<b>22U ER/L 6.0 ISO</b>		2.6	11.0	<b>22U IR/L 6.0 ISO</b>		2.1	11.0
5.5	27	5/8	<b>27 ER 5.5 ISO</b>	<b>27 EL 5.5 ISO</b>	1.9	2.7	<b>27 IR 5.5 ISO</b>	<b>27 IL 5.5 ISO</b>	1.6	2.3
6.0	27	5/8	<b>27 ER 6.0 ISO</b>	<b>27 EL 6.0 ISO</b>	2.0	2.9	<b>27 IR 6.0 ISO</b>	<b>27 IL 6.0 ISO</b>	1.8	2.5
8.0	27U	5/8U	<b>27U ER/L 8.0 ISO</b>		2.4	13.7	<b>27U IR/L 8.0 ISO</b>		2.4	13.7
12.0	33U	3/4U	<b>33U ER/L 12.0 ISO</b>		2.5	16.5	<b>33U IR/L 12.0 ISO</b>		3.5	16.9

Order example: 22 IR 3.5 ISO BMA

For small bore threading see page 83

\*\* Special holder required

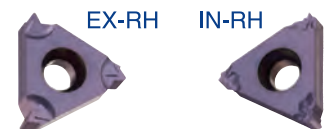
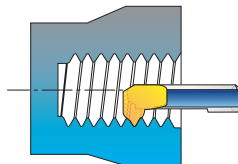

## Type B

### Ground Profile with Sintered Chip-breaker

Pitch mm	L	I.C. in	<b>EXTERNAL</b>		X	Y	<b>INTERNAL</b>		X	Y
			Ordering Code Right Hand				Ordering Code Right Hand			
0.5	11	1/4					<b>11 IR B 0.5 ISO</b>		0.6	0.6
0.75	11	1/4					<b>11 IR B 0.75 ISO</b>		0.6	0.6
0.8	11	1/4					<b>11 IR B 0.8 ISO</b>		0.6	0.6
1.0	11	1/4					<b>11 IR B 1.0 ISO</b>		0.6	0.6
1.25	11	1/4					<b>11 IR B 1.25 ISO</b>		0.8	0.9
1.5	11	1/4					<b>11 IR B 1.5 ISO</b>		0.8	0.9
1.75	11	1/4					<b>11 IR B 1.75 ISO</b>		0.8	0.9
2.0	11	1/4					<b>11 IR B 2.0 ISO</b>		0.8	0.9
0.8	16	3/8	<b>16 ER B 0.8 ISO</b>		0.6	0.6				
1.0	16	3/8	<b>16 ER B 1.0 ISO</b>		0.7	0.7	<b>16 IR B 1.0 ISO</b>		0.6	0.7
1.25	16	3/8	<b>16 ER B 1.25 ISO</b>		0.8	0.9	<b>16 IR B 1.25 ISO</b>		0.8	0.9
1.5	16	3/8	<b>16 ER B 1.5 ISO</b>		0.8	1.0	<b>16 IR B 1.5 ISO</b>		0.8	1.0
1.75	16	3/8	<b>16 ER B 1.75 ISO</b>		0.9	1.2	<b>16 IR B 1.75 ISO</b>		0.9	1.2
2.0	16	3/8	<b>16 ER B 2.0 ISO</b>		1.0	1.3	<b>16 IR B 2.0 ISO</b>		1.0	1.3
2.5	16	3/8	<b>16 ER B 2.5 ISO</b>		1.1	1.5	<b>16 IR B 2.5 ISO</b>		1.1	1.5
3.0	16	3/8	<b>16 ER B 3.0 ISO</b>		1.2	1.6	<b>16 IR B 3.0 ISO</b>		1.1	1.5

Order example: 16 IR B 1.5 ISO BMA

For Carbide Grade and Cutting Speed see page 60-61



## ISO - metric Vertical

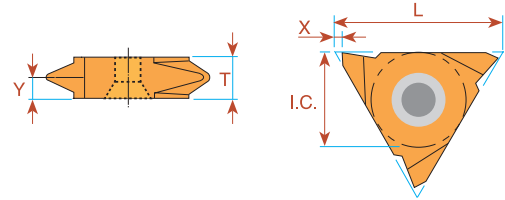

Pitch mm	L	I.C. in	<b>EXTERNAL</b>		<b>INTERNAL</b>		X	Y	T
			Right Hand	Left Hand	Right Hand	Left Hand			
0.5	16	3/8	<b>16V ER 0.5 ISO</b>	<b>16V EL 0.5 ISO</b>			1.0	0.6	3.6
0.75	16	3/8	<b>16V ER 0.75 ISO</b>	<b>16V EL 0.75 ISO</b>			1.0	0.6	3.6
0.8	16	3/8	<b>16V ER 0.8 ISO</b>	<b>16V EL 0.8 ISO</b>			1.0	0.6	3.6
1.0	16	3/8	<b>16V ER 1.0 ISO</b>	<b>16V EL 1.0 ISO</b>			1.0	0.7	3.6
1.25	16	3/8	<b>16V ER 1.25 ISO</b>	<b>16V EL 1.25 ISO</b>			1.0	0.9	3.6
1.5	16	3/8	<b>16V ER 1.5 ISO</b>	<b>16V EL 1.5 ISO</b>			1.0	0.9	3.6
1.75	16	3/8	<b>16V ER 1.75 ISO</b>	<b>16V EL 1.75 ISO</b>			1.0	1.2	3.6
2.0	16	3/8	<b>16V ER 2.0 ISO</b>	<b>16V EL 2.0 ISO</b>			1.0	1.3	3.6
2.5	16	3/8	<b>16V ER 2.5 ISO</b>	<b>16V EL 2.5 ISO</b>			1.0	1.5	3.6
3.0	16	3/8	<b>16V ER 3.0 ISO</b>	<b>16V EL 3.0 ISO</b>			1.0	1.7	3.6
* 8.0	27	5/8	<b>27V ER 8.0 ISO</b>	<b>27V EL 8.0 ISO</b>	<b>27V IR 8.0 ISO</b>	<b>27 IL 8.0 ISO</b>	1.8	5.2	10.4
** 10.0	27	5/8	<b>27V ER 10.0 ISO</b>	<b>27V EL 10.0 ISO</b>	<b>27V IR 10.0 ISO</b>	<b>27 IL 10.0 ISO</b>	1.8	5.2	10.4

Order example: 16V ER 1.5 ISO BMA

\* Minimum bore: Ø60 mm

\*\* Minimum bore: Ø72 mm

## Multitooth

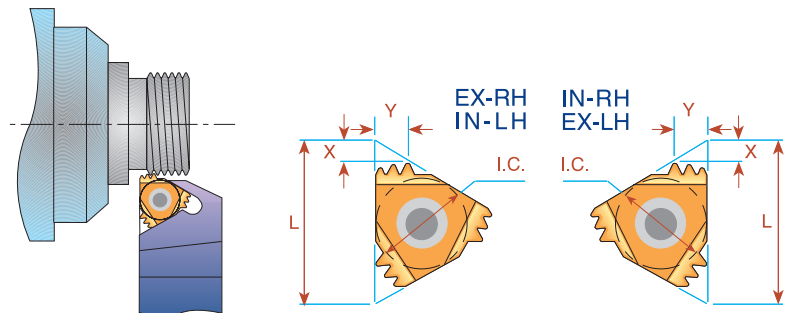

Pitch mm	L	I.C. in	Number of Teeth	<b>EXTERNAL</b>	Anvil	<b>INTERNAL</b>	Anvil	X	Y
				Ordering Code		Ordering Code			
1.0	16	3/8	3	<b>16 ER 1.0 ISO 3M</b>	AE16M	<b>16 IR 1.0 ISO 3M</b>	AI16M	1.7	2.5
1.5	16	3/8	2	<b>16 ER 1.5 ISO 2M</b>	AE16M	<b>16 IR 1.5 ISO 2M</b>	AI16M	1.5	2.3
1.5	22	1/2	3	<b>22 ER 1.5 ISO 3M</b>	AE22M	<b>22 IR 1.5 ISO 3M</b>	AI22M	2.3	3.7
2.0	22	1/2	2	<b>22 ER 2.0 ISO 2M</b>	AE22M	<b>22 IR 2.0 ISO 2M</b>	AI22M	2.0	3.0
2.0	22	1/2	3	<b>22 ER 2.0 ISO 3M</b>	AE22M	<b>22 IR 2.0 ISO 3M</b>	AI22M	3.1	5.0
3.0	27	5/8	2	<b>27 ER 3.0 ISO 2M</b>	AE27M	<b>27 IR 3.0 ISO 2M</b>	AI27M	2.9	4.6

Order example: 22 IR 2.0 ISO 2M BMA

For recommended number of passes see page 62

For Carbide Grade and Cutting Speed see page 60-61

## UN - Unified UNC, UNF, UNEF, UNS

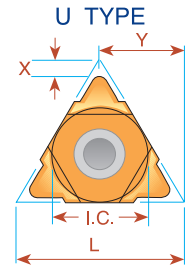
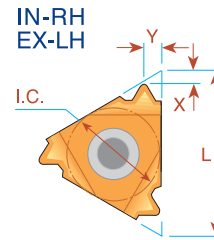
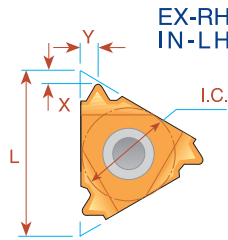
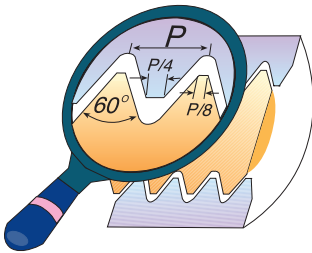

Pitch TPI	L	I.C. in	EXTERNAL			INTERNAL				
			Ordering Code		X	Y	Ordering Code		X	Y
Right Hand	Left Hand	Right Hand	Left Hand							
32	6	5/32	<i>ULTRA MINIATURE</i> →			<b>*06 IR 32 UN</b>	<b>*06 IL 32 UN</b>	0.8	0.5	
28	6	5/32				<b>*06 IR 28 UN</b>	<b>*06 IL 28 UN</b>	0.8	0.6	
24	6	5/32				<b>*06 IR 24 UN</b>	<b>*06 IL 24 UN</b>	0.7	0.6	
20	6	5/32				<b>*06 IR 20 UN</b>	<b>*06 IL 20 UN</b>	0.6	0.6	
18	6	5/32				<b>*06 IR 18 UN</b>	<b>*06 IL 18 UN</b>	0.6	0.7	
32	8	3/16	<i>MINIATURE</i> →			<b>*08 IR 32 UN</b>	<b>*08 IL 32 UN</b>	0.6	0.5	
28	8	3/16				<b>*08 IR 28 UN</b>	<b>*08 IL 28 UN</b>	0.6	0.6	
24	8	3/16				<b>*08 IR 24 UN</b>	<b>*08 IL 24 UN</b>	0.6	0.6	
20	8	3/16				<b>*08 IR 20 UN</b>	<b>*08 IL 20 UN</b>	0.6	0.7	
18	8	3/16				<b>*08 IR 18 UN</b>	<b>*08 IL 18 UN</b>	0.6	0.7	
16	8	3/16	<b>*08 IR 16 UN</b>	<b>*08 IL 16 UN</b>	0.6	0.7				
14	8	3/16	<b>*08 IR 14 UN</b>	<b>*08 IL 14 UN</b>	0.6	0.8				
13	8	3/16	<b>**08 IR 13 UN</b>		0.8	0.9				
13	8U	3/16U	<i>"U" MINIATURE</i> →			<b>*08U IR/L 13 UN</b>		1.0	4.0	
12	8U	3/16U				<b>*08U IR/L 12 UN</b>		0.9	4.0	
11	8U	3/16U				<b>*08U IR/L 11 UN</b>		0.9	4.0	
72	11	1/4	<b>11 ER 72 UN</b>	<b>11 EL 72 UN</b>	0.8	0.4	<b>11 IR 72 UN</b>	<b>11 IL 72 UN</b>	0.8	0.3
64	11	1/4	<b>11 ER 64 UN</b>	<b>11 EL 64 UN</b>	0.8	0.4	<b>11 IR 64 UN</b>	<b>11 IL 64 UN</b>	0.8	0.4
56	11	1/4	<b>11 ER 56 UN</b>	<b>11 EL 56 UN</b>	0.7	0.4	<b>11 IR 56 UN</b>	<b>11 IL 56 UN</b>	0.7	0.4
48	11	1/4	<b>11 ER 48 UN</b>	<b>11 EL 48 UN</b>	0.6	0.6	<b>11 IR 48 UN</b>	<b>11 IL 48 UN</b>	0.6	0.6
44	11	1/4	<b>11 ER 44 UN</b>	<b>11 EL 44 UN</b>	0.6	0.6	<b>11 IR 44 UN</b>	<b>11 IL 44 UN</b>	0.6	0.6
40	11	1/4	<b>11 ER 40 UN</b>	<b>11 EL 40 UN</b>	0.6	0.6	<b>11 IR 40 UN</b>	<b>11 IL 40 UN</b>	0.6	0.6
36	11	1/4	<b>11 ER 36 UN</b>	<b>11 EL 36 UN</b>	0.6	0.6	<b>11 IR 36 UN</b>	<b>11 IL 36 UN</b>	0.6	0.6
32	11	1/4	<b>11 ER 32 UN</b>	<b>11 EL 32 UN</b>	0.6	0.6	<b>11 IR 32 UN</b>	<b>11 IL 32 UN</b>	0.6	0.6
28	11	1/4	<b>11 ER 28 UN</b>	<b>11 EL 28 UN</b>	0.6	0.7	<b>11 IR 28 UN</b>	<b>11 IL 28 UN</b>	0.6	0.7
27	11	1/4	<b>11 ER 27 UN</b>	<b>11 EL 27 UN</b>	0.7	0.8	<b>11 IR 27 UN</b>	<b>11 IL 27 UN</b>	0.7	0.8
24	11	1/4	<b>11 ER 24 UN</b>	<b>11 EL 24 UN</b>	0.7	0.8	<b>11 IR 24 UN</b>	<b>11 IL 24 UN</b>	0.7	0.8
20	11	1/4	<b>11 ER 20 UN</b>	<b>11 EL 20 UN</b>	0.8	0.9	<b>11 IR 20 UN</b>	<b>11 IL 20 UN</b>	0.8	0.9
18	11	1/4	<b>11 ER 18 UN</b>	<b>11 EL 18 UN</b>	0.8	1.0	<b>11 IR 18 UN</b>	<b>11 IL 18 UN</b>	0.8	1.0
16	11	1/4	<b>11 ER 16 UN</b>	<b>11 EL 16 UN</b>	0.9	1.1	<b>11 IR 16 UN</b>	<b>11 IL 16 UN</b>	0.9	1.1
14	11	1/4	<b>11 ER 14 UN</b>	<b>11 EL 14 UN</b>	0.9	1.1	<b>11 IR 14 UN</b>	<b>11 IL 14 UN</b>	0.9	1.1
13	11	1/4					<b>11 IR 13 UN</b>	<b>11 IL 13 UN</b>	0.8	1.0
12	11	1/4					<b>11 IR 12 UN</b>	<b>11 IL 12 UN</b>	0.9	1.1
11	11	1/4					<b>11 IR 11 UN</b>	<b>11 IL 11 UN</b>	0.8	1.1
72	16	3/8	<b>16 ER 72 UN</b>	<b>16 EL 72 UN</b>	0.8	0.4	<b>16 IR 72 UN</b>	<b>16 IL 72 UN</b>	0.8	0.3
64	16	3/8	<b>16 ER 64 UN</b>	<b>16 EL 64 UN</b>	0.8	0.4	<b>16 IR 64 UN</b>	<b>16 IL 64 UN</b>	0.8	0.4
56	16	3/8	<b>16 ER 56 UN</b>	<b>16 EL 56 UN</b>	0.7	0.4	<b>16 IR 56 UN</b>	<b>16 IL 56 UN</b>	0.7	0.4
48	16	3/8	<b>16 ER 48 UN</b>	<b>16 EL 48 UN</b>	0.6	0.6	<b>16 IR 48 UN</b>	<b>16 IL 48 UN</b>	0.6	0.6
44	16	3/8	<b>16 ER 44 UN</b>	<b>16 EL 44 UN</b>	0.6	0.6	<b>16 IR 44 UN</b>	<b>16 IL 44 UN</b>	0.6	0.6
40	16	3/8	<b>16 ER 40 UN</b>	<b>16 EL 40 UN</b>	0.6	0.6	<b>16 IR 40 UN</b>	<b>16 IL 40 UN</b>	0.6	0.6
36	16	3/8	<b>16 ER 36 UN</b>	<b>16 EL 36 UN</b>	0.6	0.6	<b>16 IR 36 UN</b>	<b>16 IL 36 UN</b>	0.6	0.6

\* Available only in BXC and BMA grades

\*\* To be used with Holder SIR 0009 K08 on page 47



# Thread Turning Inserts

## UN - Unified **UNC, UNF, UNEF, UNS**

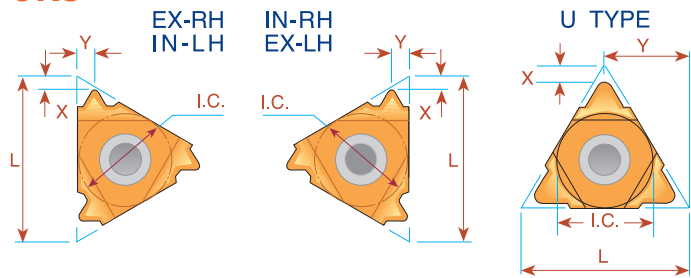
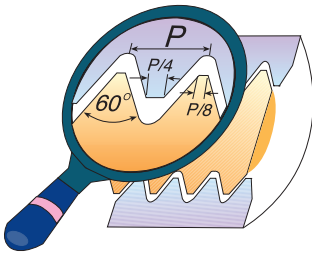

Pitch TPI	L	I.C. in	EXTERNAL				INTERNAL			
			Ordering Code		X	Y	Ordering Code		X	Y
			Right Hand	Left Hand			Right Hand	Left Hand		
32	16	3/8	<b>16 ER 32 UN</b>	<b>16 EL 32 UN</b>	0.6	0.6	<b>16 IR 32 UN</b>	<b>16 IL 32 UN</b>	0.6	0.6
28	16	3/8	<b>16 ER 28 UN</b>	<b>16 EL 28 UN</b>	0.6	0.7	<b>16 IR 28 UN</b>	<b>16 IL 28 UN</b>	0.6	0.7
27	16	3/8	<b>16 ER 27 UN</b>	<b>16 EL 27 UN</b>	0.7	0.8	<b>16 IR 27 UN</b>	<b>16 IL 27 UN</b>	0.7	0.8
24	16	3/8	<b>16 ER 24 UN</b>	<b>16 EL 24 UN</b>	0.7	0.8	<b>16 IR 24 UN</b>	<b>16 IL 24 UN</b>	0.7	0.8
20	16	3/8	<b>16 ER 20 UN</b>	<b>16 EL 20 UN</b>	0.8	0.9	<b>16 IR 20 UN</b>	<b>16 IL 20 UN</b>	0.8	0.9
18	16	3/8	<b>16 ER 18 UN</b>	<b>16 EL 18 UN</b>	0.8	1.0	<b>16 IR 18 UN</b>	<b>16 IL 18 UN</b>	0.8	1.0
16	16	3/8	<b>16 ER 16 UN</b>	<b>16 EL 16 UN</b>	0.9	1.1	<b>16 IR 16 UN</b>	<b>16 IL 16 UN</b>	0.9	1.1
14	16	3/8	<b>16 ER 14 UN</b>	<b>16 EL 14 UN</b>	1.0	1.2	<b>16 IR 14 UN</b>	<b>16 IL 14 UN</b>	0.9	1.2
13	16	3/8	<b>16 ER 13 UN</b>	<b>16 EL 13 UN</b>	1.0	1.3	<b>16 IR 13 UN</b>	<b>16 IL 13 UN</b>	1.0	1.3
12	16	3/8	<b>16 ER 12 UN</b>	<b>16 EL 12 UN</b>	1.1	1.4	<b>16 IR 12 UN</b>	<b>16 IL 12 UN</b>	1.1	1.4
11.5	16	3/8	<b>16 ER 11.5 UN</b>	<b>16 EL 11.5 UN</b>	1.1	1.5	<b>16 IR 11.5 UN</b>	<b>16 IL 11.5 UN</b>	1.1	1.5
11	16	3/8	<b>16 ER 11 UN</b>	<b>16 EL 11 UN</b>	1.1	1.5	<b>16 IR 11 UN</b>	<b>16 IL 11 UN</b>	1.1	1.5
10	16	3/8	<b>16 ER 10 UN</b>	<b>16 EL 10 UN</b>	1.1	1.5	<b>16 IR 10 UN</b>	<b>16 IL 10 UN</b>	1.1	1.5
9	16	3/8	<b>16 ER 9 UN</b>	<b>16 EL 9 UN</b>	1.2	1.7	<b>16 IR 9 UN</b>	<b>16 IL 9 UN</b>	1.2	1.7
8	16	3/8	<b>16 ER 8 UN</b>	<b>16 EL 8 UN</b>	1.2	1.6	<b>16 IR 8 UN</b>	<b>16 IL 8 UN</b>	1.1	1.5
7	22	1/2	<b>22 ER 7 UN</b>	<b>22 EL 7 UN</b>	1.6	2.3	<b>22 IR 7 UN</b>	<b>22 IL 7 UN</b>	1.6	2.3
6	22	1/2	<b>22 ER 6 UN</b>	<b>22 EL 6 UN</b>	1.6	2.3	<b>22 IR 6 UN</b>	<b>22 IL 6 UN</b>	1.6	2.3
5	22	1/2	<b>22 ER 5 UN</b>	<b>22 EL 5 UN</b>	1.7	2.5	<b>22 IR 5 UN</b>	<b>22 IL 5 UN</b>	1.6	2.3
4.5	22U	1/2U	<b>22U ER/L 4.5 UN</b>		2.0	11.0	<b>22U IR/L 4.5 UN</b>		2.4	11.0
4	22U	1/2U	<b>22U ER/L 4 UN</b>		2.0	11.0	<b>22U IR/L 4 UN</b>		2.4	11.0
4.5	27	5/8	<b>27 ER 4.5 UN</b>	<b>27 EL 4.5 UN</b>	1.9	2.7	<b>27 IR 4.5 UN</b>	<b>27 IL 4.5 UN</b>	1.7	2.4
4	27	5/8	<b>27 ER 4 UN</b>	<b>27 EL 4 UN</b>	2.1	3.0	<b>27 IR 4 UN</b>	<b>27 IL 4 UN</b>	1.8	2.7
3	27U	5/8U	<b>27U ER/L 3 UN</b>		2.5	13.7	<b>27U IR/L 3 UN</b>		2.7	13.7
2	33U	3/4U	<b>33U ER/L 2 UN</b>		2.8	16.5	<b>27U IR/L 2 UN</b>		3.6	16.9

Order example: 22ER 7 UN BMA

For small bore threading see page 83

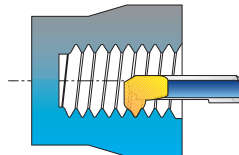

For Carbide Grade and Cutting Speed see page 60-61

## UN - Unified Vertical

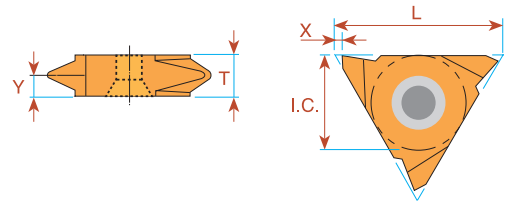

Pitch TPI	L	I.C. in	<b>EXTERNAL</b>		<b>INTERNAL</b>		X	Y	T
			Ordering Code Right Hand	Ordering Code Left Hand	Ordering Code Right Hand	Ordering Code Left Hand			
32	16	3/8	<b>16V ER 32 UN</b>	<b>16V EL 32 UN</b>			1.0	0.6	3.6
28	16	3/8	<b>16V ER 28 UN</b>	<b>16V EL 28 UN</b>			1.0	0.7	3.6
24	16	3/8	<b>16V ER 24 UN</b>	<b>16V EL 24 UN</b>			1.0	0.8	3.6
20	16	3/8	<b>16V ER 20 UN</b>	<b>16V EL 20 UN</b>			1.0	0.9	3.6
18	16	3/8	<b>16V ER 18 UN</b>	<b>16V EL 18 UN</b>			1.0	1.0	3.6
16	16	3/8	<b>16V ER 16 UN</b>	<b>16V EL 16 UN</b>			1.0	1.1	3.6
14	16	3/8	<b>16V ER 14 UN</b>	<b>16V EL 14 UN</b>			1.0	1.2	3.6
12	16	3/8	<b>16V ER 12 UN</b>	<b>16V EL 12 UN</b>			1.0	1.4	3.6
10	16	3/8	<b>16V ER 10 UN</b>	<b>16V EL 10 UN</b>			1.0	1.5	3.6
8	16	3/8	<b>16V ER 8 UN</b>	<b>16V EL 8 UN</b>			1.0	1.6	3.6
7	22	1/2	<b>22V ER 7 UN</b>	<b>22V EL 7 UN</b>			1.2	2.3	4.8
* 3	27	5/8	<b>27V ER 3 UN</b>	<b>27V EL 3 UN</b>	<b>27V IR 3 UN</b>	<b>27 IL 3 UN</b>	1.8	5.2	10.4

Order example: 22V ER 7UN MXC

\* Minimum bore: Ø65 mm

## UN - Unified Type B **UNC, UNF, UNEF, UNS**

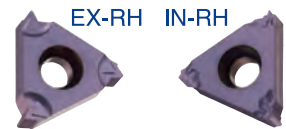

### Ground Profile with Sintered Chip-breaker

Pitch TPI	L	I.C. in	<b>EXTERNAL</b>		X	Y	<b>INTERNAL</b>		X	Y
			Ordering Code Right Hand				Ordering Code Right Hand			
32	11	1/4					<b>11 IR B 32 UN</b>		0.6	0.6
28	11	1/4					<b>11 IR B 28 UN</b>		0.6	0.6
24	11	1/4					<b>11 IR B 24 UN</b>		0.6	0.6
20	11	1/4					<b>11 IR B 20 UN</b>		0.8	0.9
18	11	1/4					<b>11 IR B 18 UN</b>		0.8	0.9
16	11	1/4					<b>11 IR B 16 UN</b>		0.8	0.9
14	11	1/4					<b>11 IR B 14 UN</b>		0.8	0.9
12	11	1/4					<b>11 IR B 12 UN</b>		0.8	0.9
24	16	3/8	<b>16 ER B 24 UN</b>		0.7	0.8	<b>16 IR B 24 UN</b>		0.7	0.8
20	16	3/8	<b>16 ER B 20 UN</b>		0.8	0.9	<b>16 IR B 20 UN</b>		0.8	0.9
18	16	3/8	<b>16 ER B 18 UN</b>		0.8	1.0	<b>16 IR B 18 UN</b>		0.8	1.0
16	16	3/8	<b>16 ER B 16 UN</b>		0.9	1.1	<b>16 IR B 16 UN</b>		0.9	1.1
14	16	3/8	<b>16 ER B 14 UN</b>		1.0	1.2	<b>16 IR B 14 UN</b>		0.9	1.2
13	16	3/8	<b>16 ER B 13 UN</b>		1.0	1.3				
12	16	3/8	<b>16 ER B 12 UN</b>		1.1	1.4	<b>16 IR B 12 UN</b>		1.1	1.4
11	16	3/8	<b>16 ER B 11 UN</b>		1.1	1.5				
10	16	3/8	<b>16 ER B 10 UN</b>		1.1	1.5	<b>16 IR B 10 UN</b>		1.1	1.5
9	16	3/8	<b>16 ER B 9 UN</b>		1.2	1.7				
8	16	3/8	<b>16 ER B 8 UN</b>		1.2	1.6	<b>16 IR B 8 UN</b>		1.1	1.1

Order example: 16 IR B 12 UN BMA

## Multitooth

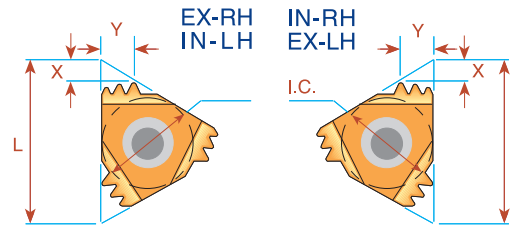
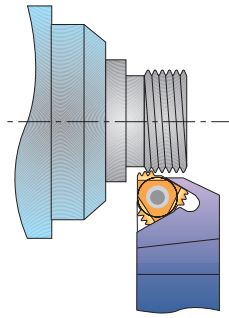

Pitch TPI	L	I.C. in	Number of Teeth	<b>EXTERNAL</b>		<b>INTERNAL</b>		X	Y
				Ordering Code	Anvil	Ordering Code	Anvil		
24	16	3/8	2	<b>16 ER 24 UN 2M</b>	AE16M	<b>16 IR 24 UN 2M</b>	AI16M	1.1	1.7
20	16	3/8	2	<b>16 ER 20 UN 2M</b>	AE16M	<b>16 IR 20 UN 2M</b>	AI16M	1.4	2.0
18	16	3/8	2	<b>16 ER 18 UN 2M</b>	AE16M	<b>16 IR 18 UN 2M</b>	AI16M	1.5	2.2
16	16	3/8	2	<b>16 ER 16 UN 2M</b>	AE16M	<b>16 IR 16 UN 2M</b>	AI16M	1.5	2.3
14	16	3/8	2	<b>16 ER 14 UN 2M</b>	AE16M	<b>16 IR 14 UN 2M</b>	AI16M	1.7	2.7
12	16	3/8	2	<b>16 ER 12 UN 2M</b>	AE16M	<b>16 IR 12 UN 2M</b>	AI16M	2.0	3.1
16	22	1/2	3	<b>22 ER 16 UN 3M</b>	AE22M	<b>22 IR 16 UN 3M</b>	AI22M	2.5	4.0
13	22	1/2	3	<b>22 ER 13 UN 3M</b>	AE22M	-		3.0	4.9
12	22	1/2	2	<b>22 ER 12 UN 2M</b>	AE22M	<b>22 IR 12 UN 2M</b>	AI22M	2.2	3.4
12	22	1/2	3	<b>22 ER 12 UN 3M</b>	AE22M	<b>22 IR 12 UN 3M</b>	AI22M	3.3	5.3
8	27	5/8	2	<b>27 ER 8 UN 2M</b>	AE27M	<b>27 IR 8 UN 2M</b>	AI27M	3.1	4.9

Order example: 22 IR 16 UN 3M BMA

For recommended number of passes see page 62

For Carbide Grade and Cutting Speed see page 60-61

## Whitworth - 55° BSW, BSF, BSP, BSB

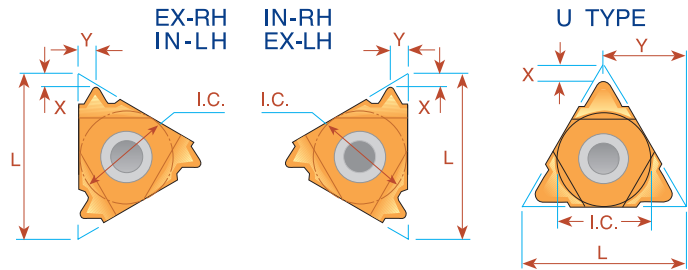
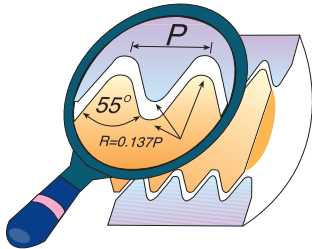

Pitch TPI	L	I.C. in	<b>EXTERNAL</b>		<b>INTERNAL</b>		X	Y
			Right Hand	Left Hand	Right Hand	Left Hand		
26	6	5/32	<i>ULTRA MINIATURE</i> →		*06 IR 26 W	*06 IL 26 W	0.7	0.6
22	6	5/32			*06 IR 22 W	*06 IL 22 W	0.6	0.6
20	6	5/32			*06 IR 20 W	*06 IL 20 W	0.6	0.7
18	6	5/32			*06 IR 18 W	*06 IL 18 W	0.6	0.7
28	8	3/16	<i>MINIATURE</i> →		*08 IR 28 W	*08 IL 28 W	0.6	0.6
24	8	3/16			*08 IR 24 W	*08 IL 24 W	0.6	0.6
20	8	3/16			*08 IR 20 W	*08 IL 20 W	0.6	0.7
19	8	3/16			*08 IR 19 W	*08 IL 19 W	0.6	0.7
18	8	3/16			*08 IR 18 W	*08 IL 18 W	0.6	0.7
16	8	3/16			*08 IR 16 W	*08 IL 16 W	0.6	0.7
14	8U	3/16U	<i>"U" MINIATURE</i> →		*08U IR/L 14 W		1.0	4.0
12	8U	3/16U			*08U IR/L 12 W		0.9	4.0
11	8U	3/16U			*08U IR/L 11 W		0.9	4.0
72	11	1/4	11 ER 72 W	11 EL 72 W	11 IR 72 W	11 IL 72 W	0.7	0.4
60	11	1/4	11 ER 60 W	11 EL 60 W	11 IR 60 W	11 IL 60 W	0.7	0.4
56	11	1/4	11 ER 56 W	11 EL 56 W	11 IR 56 W	11 IL 56 W	0.7	0.4
48	11	1/4	11 ER 48 W	11 EL 48 W	11 IR 48 W	11 IL 48 W	0.6	0.6
40	11	1/4	11 ER 40 W	11 EL 40 W	11 IR 40 W	11 IL 40 W	0.6	0.6
36	11	1/4	11 ER 36 W	11 EL 36 W	11 IR 36 W	11 IL 36 W	0.6	0.6
32	11	1/4	11 ER 32 W	11 EL 32 W	11 IR 32 W	11 IL 32 W	0.6	0.6
28	11	1/4	11 ER 28 W	11 EL 28 W	11 IR 28 W	11 IL 28 W	0.6	0.7
26	11	1/4	11 ER 26 W	11 EL 26 W	11 IR 26 W	11 IL 26 W	0.7	0.7
24	11	1/4	11 ER 24 W	11 EL 24 W	11 IR 24 W	11 IL 24 W	0.7	0.8
22	11	1/4	11 ER 22 W	11 EL 22 W	11 IR 22 W	11 IL 22 W	0.8	0.9
20	11	1/4	11 ER 20 W	11 EL 20 W	11 IR 20 W	11 IL 20 W	0.8	0.9
19	11	1/4	11 ER 19 W	11 EL 19 W	11 IR 19 W	11 IL 19 W	0.8	1.0
18	11	1/4	11 ER 18 W	11 EL 18 W	11 IR 18 W	11 IL 18 W	0.8	1.0
16	11	1/4	11 ER 16 W	11 EL 16 W	11 IR 16 W	11 IL 16 W	0.9	1.1
14	11	1/4	11 ER 14 W	11 EL 14 W	11 IR 14 W	11 IL 14 W	0.9	1.1
12	11	1/4			11 IR 12 W	11 IL 12 W	0.1	1.1
11	11	1/4			(1) 11 IR 11 W	(1) 11 IL 11 W	0.9	1.2
72	16	3/8	16 ER 72 W	16 EL 72 W	16 IR 72 W	16 IL 72 W	0.7	0.4
60	16	3/8	16 ER 60 W	16 EL 60 W	16 IR 60 W	16 IL 60 W	0.7	0.4
56	16	3/8	16 ER 56 W	16 EL 56 W	16 IR 56 W	16 IL 56 W	0.7	0.4
48	16	3/8	16 ER 48 W	16 EL 48 W	16 IR 48 W	16 IL 48 W	0.6	0.6
40	16	3/8	16 ER 40 W	16 EL 40 W	16 IR 40 W	16 IL 40 W	0.6	0.6
36	16	3/8	16 ER 36 W	16 EL 36 W	16 IR 36 W	16 IL 36 W	0.6	0.6
32	16	3/8	16 ER 32 W	16 EL 32 W	16 IR 32 W	16 IL 32 W	0.6	0.6
28	16	3/8	16 ER 28 W	16 EL 28 W	16 IR 28 W	16 IL 28 W	0.6	0.7
26	16	3/8	16 ER 26 W	16 EL 26 W	16 IR 26 W	16 IL 26 W	0.7	0.7
24	16	3/8	16 ER 24 W	16 EL 24 W	16 IR 24 W	16 IL 24 W	0.7	0.8

\* Available only in BXC and BMA grades

(1) Special holder is required or standard holder can be amended by customer.



## Whitworth - 55° BSW, BSF, BSP, BSB

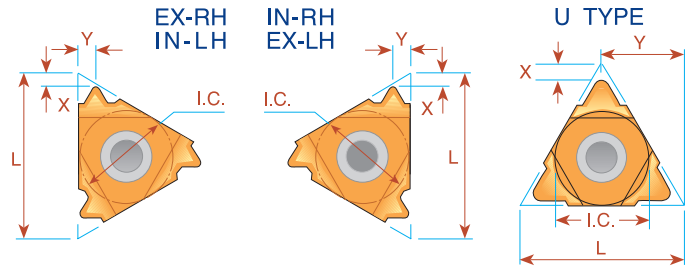
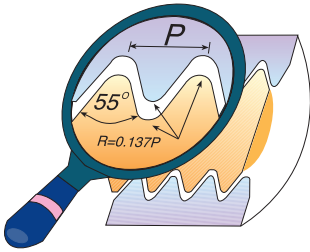

Pitch TPI	L	I.C. in	<b>EXTERNAL</b>		<b>INTERNAL</b>		X	Y
			Right Hand	Left Hand	Right Hand	Left Hand		
22	16	3/8	<b>16 ER 22 W</b>	<b>16 EL 22 W</b>	<b>16 IR 22 W</b>	<b>16 IL 22 W</b>	0.8	0.9
20	16	3/8	<b>16 ER 20 W</b>	<b>16 EL 20 W</b>	<b>16 IR 20 W</b>	<b>16 IL 20 W</b>	0.8	0.9
19	16	3/8	<b>16 ER 19 W</b>	<b>16 EL 19 W</b>	<b>16 IR 19 W</b>	<b>16 IL 19 W</b>	0.8	1.0
18	16	3/8	<b>16 ER 18 W</b>	<b>16 EL 18 W</b>	<b>16 IR 18 W</b>	<b>16 IL 18 W</b>	0.8	1.0
16	16	3/8	<b>16 ER 16 W</b>	<b>16 EL 16 W</b>	<b>16 IR 16 W</b>	<b>16 IL 16 W</b>	0.9	1.1
14	16	3/8	<b>16 ER 14 W</b>	<b>16 EL 14 W</b>	<b>16 IR 14 W</b>	<b>16 IL 14 W</b>	1.0	1.2
12	16	3/8	<b>16 ER 12 W</b>	<b>16 EL 12 W</b>	<b>16 IR 12 W</b>	<b>16 IL 12 W</b>	1.1	1.4
11	16	3/8	<b>16 ER 11 W</b>	<b>16 EL 11 W</b>	<b>16 IR 11 W</b>	<b>16 IL 11 W</b>	1.1	1.5
10	16	3/8	<b>16 ER 10 W</b>	<b>16 EL 10 W</b>	<b>16 IR 10 W</b>	<b>16 IL 10 W</b>	1.1	1.5
9	16	3/8	<b>16 ER 9 W</b>	<b>16 EL 9 W</b>	<b>16 IR 9 W</b>	<b>16 IL 9 W</b>	1.2	1.7
8	16	3/8	<b>16 ER 8 W</b>	<b>16 EL 8 W</b>	<b>16 IR 8 W</b>	<b>16 IL 8 W</b>	1.2	1.5
7	22	1/2	<b>22 ER 7 W</b>	<b>22 EL 7 W</b>	<b>22 IR 7 W</b>	<b>22 IL 7 W</b>	1.6	2.3
6	22	1/2	<b>22 ER 6 W</b>	<b>22 EL 6 W</b>	<b>22 IR 6 W</b>	<b>22 IL 6 W</b>	1.6	2.3
5	22	1/2	<b>22 ER 5 W</b>	<b>22 EL 5 W</b>	<b>22 IR 5 W</b>	<b>22 IL 5 W</b>	1.7	2.4
4.5	22U	1/2U	<b>22U E/R/L 4.5 W</b>				2.3	11.0
4	22U	1/2U	<b>22U E/R/L 4 W</b>				2.8	11.0
4.5	27	5/8	<b>27 ER 4.5 W</b>	<b>27 EL 4.5 W</b>	<b>27 IR 4.5 W</b>	<b>27 IL 4.5 W</b>	1.8	2.6
4	27	5/8	<b>27 ER 4 W</b>	<b>27 EL 4 W</b>	<b>27 IR 4 W</b>	<b>27 IL 4 W</b>	2.0	2.9
3.5	27U	5/8U	<b>27U E/R/L 3.5 W</b>				2.1	13.7
3.25	27U	5/8U	<b>27U E/R/L 3.25 W</b>				2.0	13.7
3	27U	5/8U	<b>27U E/R/L 3 W</b>				2.3	13.7
2.75	27U	5/8U	<b>27U E/R/L 2.75 W</b>				2.4	13.7

Order example: 16 IR 18 W BMA

For Carbide Grade and Cutting Speed see page 60-61

## Whitworth - 55° BSW, BSF, BSP, BSB

### Type B

Ground Profile with Sintered Chip-breaker

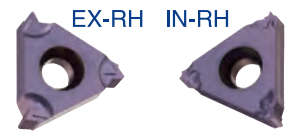

Pitch TPI	L	I.C. in	<b>EXTERNAL</b>	<b>INTERNAL</b>	X	Y
			Ordering Code Right Hand	Ordering Code Right Hand		
28	11	1/4		<b>11 IR B 28 W</b>	0.6	0.6
24	11	1/4		<b>11 IR B 24 W</b>	0.6	0.6
20	11	1/4		<b>11 IR B 20 W</b>	0.8	0.9
19	11	1/4		<b>11 IR B 19 W</b>	0.8	0.9
18	11	1/4		<b>11 IR B 18 W</b>	0.8	0.9
16	11	1/4		<b>11 IR B 16 W</b>	0.8	0.9
14	11	1/4		<b>11 IR B 14 W</b>	0.8	0.9
19	16	3/8	<b>16 ER B 19 W</b>	<b>16 IR B 19 W</b>	0.8	1.0
16	16	3/8	<b>16 ER B 16 W</b>	<b>16 IR B 16 W</b>	0.9	1.1
14	16	3/8	<b>16 ER B 14 W</b>	<b>16 IR B 14 W</b>	1.0	1.2
11	16	3/8	<b>16 ER B 11 W</b>	<b>16 IR B 11 W</b>	1.1	1.5
10	16	3/8	<b>16 ER B 10 W</b>	<b>16 IR B 10 W</b>	1.1	1.5

Order example: 16 IR B 10 W BMA

### Vertical

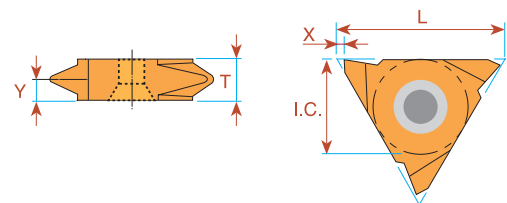

Pitch TPI	L	I.C. in	<b>EXTERNAL</b>	<b>EXTERNAL</b>	X	Y	T
			Ordering Code Right Hand	Ordering Code Left Hand			
20	16	3/8	<b>16V ER 20 W</b>	<b>16V EL 20 W</b>	1.0	0.9	3.6
19	16	3/8	<b>16V ER 19 W</b>	<b>16V EL 19 W</b>	1.0	0.9	3.6
18	16	3/8	<b>16V ER 18 W</b>	<b>16V EL 18 W</b>	1.0	1.0	3.6
16	16	3/8	<b>16V ER 16 W</b>	<b>16V EL 16 W</b>	1.0	1.0	3.6
14	16	3/8	<b>16V ER 14 W</b>	<b>16V EL 14 W</b>	1.0	1.2	3.6
12	16	3/8	<b>16V ER 12 W</b>	<b>16V EL 12 W</b>	1.0	1.4	3.6
11	16	3/8	<b>16V ER 11 W</b>	<b>16V EL 11 W</b>	1.0	1.5	3.6

Order example: 16V ER 14 W MXC



## Multitooth

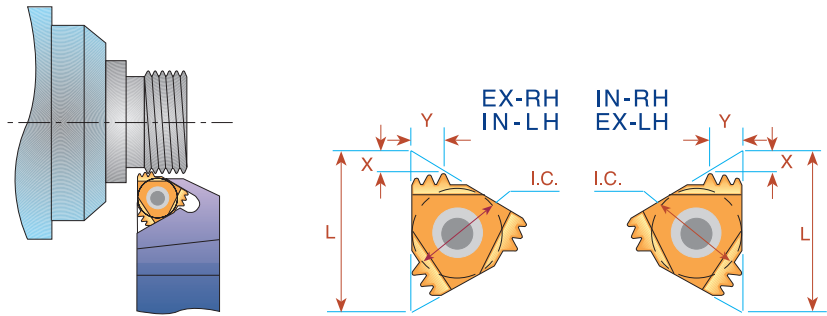

Pitch TPI	L	I.C. in	Number of Teeth	<b>EXTERNAL</b>		<b>INTERNAL</b>		X	Y
				Ordering Code	Anvil	Ordering Code	Anvil		
14	16	3/8	2	<b>16 ER 14 W 2M</b>	AE16M	<b>16 IR 14 W 2M</b>	AI16M	1.7	2.7
14	22	1/2	3	<b>22 ER 14 W 3M</b>	AE22M	<b>22 IR 14 W 3M</b>	AI22M	2.8	4.5
11	22	1/2	2	<b>22 ER 11 W 2M</b>	AE22M	<b>22 IR 11 W 2M</b>	AI22M	2.3	3.4

Order example: 16 ER 14 W 2M MXC

For recommended number of passes see page 62

For Carbide Grade and Cutting Speed see page 60-61

## NPT

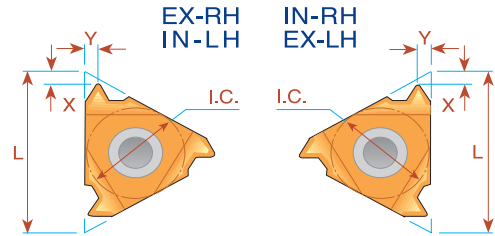
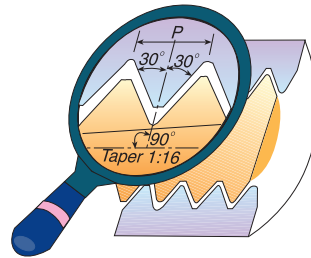

Pitch TPI	L	I.C. in	<b>EXTERNAL</b>		<b>INTERNAL</b>		X	Y
			Ordering Code Right Hand	Ordering Code Left Hand	Ordering Code Right Hand	Ordering Code Left Hand		
27	6	5/32	ULTRA MINIATURE →		*06 IR 27 NPT	*06 IL 27 NPT	0.6	0.6
27	8	3/16			*08 IR 27 NPT	*08 IL 27 NPT	0.6	0.6
18	8	3/16	MINIATURE →		*08 IR 18 NPT	*08 IL 18 NPT	0.6	0.6
27	11	1/4	11 ER 27 NPT	11 EL 27 NPT	11 IR 27 NPT	11 IL 27 NPT	0.7	0.8
18	11	1/4	11 ER 18 NPT	11 EL 18 NPT	11 IR 18 NPT	11 IL 18 NPT	0.8	1.0
14	11	1/4	11 ER 14 NPT	11 EL 14 NPT	11 IR 14 NPT	11 IL 14 NPT	0.8	1.0
27	16	3/8	16 ER 27 NPT	16 EL 27 NPT	16 IR 27 NPT	16 IL 27 NPT	0.7	0.8
18	16	3/8	16 ER 18 NPT	16 EL 18 NPT	16 IR 18 NPT	16 IL 18 NPT	0.8	1.0
14	16	3/8	16 ER 14 NPT	16 EL 14 NPT	16 IR 14 NPT	16 IL 14 NPT	0.9	1.2
11.5	16	3/8	16 ER 11.5 NPT	16 EL 11.5 NPT	16 IR 11.5 NPT	16 IL 11.5 NPT	1.1	1.5
8	16	3/8	16 ER 8 NPT	16 EL 8 NPT	16 IR 8 NPT	16 IL 8 NPT	1.3	1.8

Order example: 16 ER 14 NPT MXC

\* Available only in BXC and BMA grades

## Type B

### Ground Profile with Sintered Chip-breaker

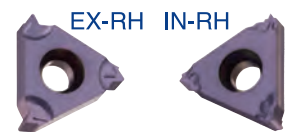

Pitch TPI	L	I.C. in	<b>EXTERNAL</b>		<b>INTERNAL</b>		X	Y
			Ordering Code Right Hand	Ordering Code Right Hand	Ordering Code Right Hand	Ordering Code Right Hand		
18	11	1/4			11 IR B 18 NPT		0.8	0.9
18	16	3/8	16 ER B 18 NPT		16 IR B 18 NPT		0.8	1.0
14	16	3/8	16 ER B 14 NPT		16 IR B 14 NPT		0.9	1.2
11.5	16	3/8	16 ER B 11.5 NPT		16 IR B 11.5 NPT		1.1	1.5
8	16	3/8	16 ER B 8 NPT		16 IR B 8 NPT		1.3	1.8

Order example: 16 IR B 11.5 NPT BMA

For Carbide Grade and Cutting Speed see page 60-61

## NPT Multitooth

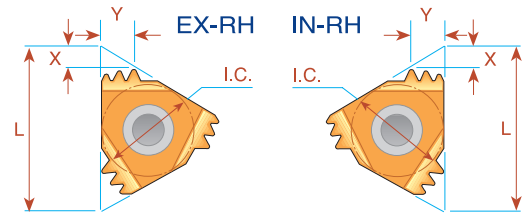
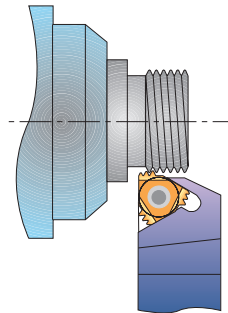

Pitch TPI	L	I.C. in	Number of Teeth	<b>EXTERNAL</b>		Anvil	<b>INTERNAL</b>		Anvil	X	Y
				Ordering Code			Ordering Code				
14	16	3/8	2	<b>16 ER 14 NPT 2M</b>		AE16M	<b>16 IR 14 NPT 2M</b>		AI16M	1.7	2.8
11.5	22	1/2	2	<b>22 ER 11.5 NPT 2M</b>		AE22M	<b>22 IR 11.5 NPT 2M</b>		AI22M	2.3	3.5
11.5	27	5/8	3	<b>27 ER 11.5 NPT 3M</b>		AE27M	<b>27 IR 11.5 NPT 3M</b>		AI27M	3.3	5.5
8	27	5/8	2	<b>27 ER 8 NPT 2M</b>		AE27M	<b>27 IR 8 NPT 2M</b>		AI27M	3.1	5.0

Order example: 22 ER 11.5 NPT 2M MXC

For recommended number of passes see page 62

## NPT Vertical

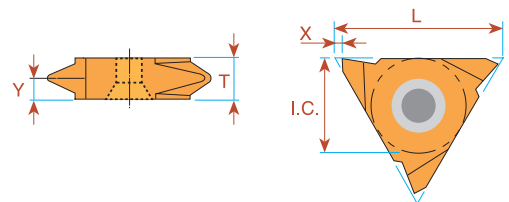

Pitch TPI	L	I.C. in	<b>EXTERNAL</b>		X	Y	T
			Ordering Code Right Hand	Ordering Code Left Hand			
27	16	3/8	<b>16V ER 27 NPT</b>	<b>16V EL 27 NPT</b>	1.0	0.8	3.6
18	16	3/8	<b>16V ER 18 NPT</b>	<b>16V EL 18 NPT</b>	1.0	1.0	3.6
14	16	3/8	<b>16V ER 14 NPT</b>	<b>16V EL 14 NPT</b>	1.0	1.2	3.6
11.5	16	3/8	<b>16V ER 11.5 NPT</b>	<b>16V EL 11.5 NPT</b>	1.0	1.5	3.6

Order example: 16V ER 14 NPT BMA

For Carbide Grade and Cutting Speed see page 60-61

## NPTF - Dryseal

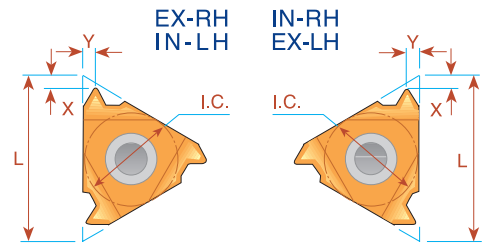
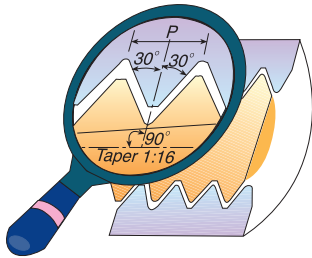

Pitch TPI	L	I.C. in	<b>EXTERNAL</b>		<b>INTERNAL</b>		X	Y
			Ordering Code Right Hand	Ordering Code Left Hand	Ordering Code Right Hand	Ordering Code Left Hand		
27	6	5/32	<i>ULTRA MINIATURE</i> →		<b>*06 IR 27 NPTF</b>	<b>*06 IL 27 NPTF</b>	0.7	0.6
27	8	3/16			<b>*08 IR 27 NPTF</b>	<b>*08 IL 27 NPTF</b>	0.6	0.6
18	8	3/16	<i>MINIATURE</i> →		<b>*08 IR 18 NPTF</b>	<b>*08 IL 18 NPTF</b>	0.6	0.6
27	11	1/4	<b>11 ER 27 NPTF</b>	<b>11 EL 27 NPTF</b>	<b>11 IR 27 NPTF</b>	<b>11 IL 27 NPTF</b>	0.7	0.7
18	11	1/4	<b>11 ER 18 NPTF</b>	<b>11 EL 18 NPTF</b>	<b>11 IR 18 NPTF</b>	<b>11 IL 18 NPTF</b>	0.8	1.0
14	11	1/4	<b>11 ER 14 NPTF</b>	<b>11 EL 14 NPTF</b>	<b>11 IR 14 NPTF</b>	<b>11 IL 14 NPTF</b>	0.8	1.0
27	16	3/8	<b>16 ER 27 NPTF</b>	<b>16 EL 27 NPTF</b>	<b>16 IR 27 NPTF</b>	<b>16 IL 27 NPTF</b>	0.7	0.7
18	16	3/8	<b>16 ER 18 NPTF</b>	<b>16 EL 18 NPTF</b>	<b>16 IR 18 NPTF</b>	<b>16 IL 18 NPTF</b>	0.8	1.0
14	16	3/8	<b>16 ER 14 NPTF</b>	<b>16 EL 14 NPTF</b>	<b>16 IR 14 NPTF</b>	<b>16 IL 14 NPTF</b>	0.9	1.2
11.5	16	3/8	<b>16 ER 11.5 NPTF</b>	<b>16 EL 11.5 NPTF</b>	<b>16 IR 11.5 NPTF</b>	<b>16 IL 11.5 NPTF</b>	1.1	1.5
8	16	3/8	<b>16 ER 8 NPTF</b>	<b>16 EL 8 NPTF</b>	<b>16 IR 8 NPTF</b>	<b>16 IL 8 NPTF</b>	1.3	1.8

Order example: 11 ER 27 NPTF MXC

\* Available only in BXC and BMA grades

## Type B

### Ground Profile with Sintered Chip-breaker

Pitch TPI	L	I.C. in	<b>INTERNAL</b> Ordering Code Right Hand	X	Y
18	11	1/4	<b>11 IR B 18 NPTF</b>	0.8	0.9



For Carbide Grade and Cutting Speed see page 60-61

## Multitooth

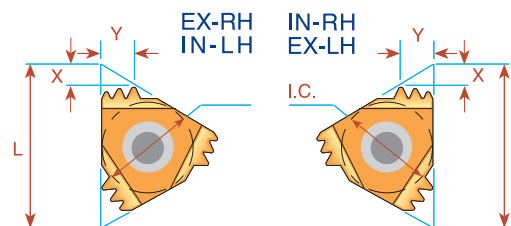
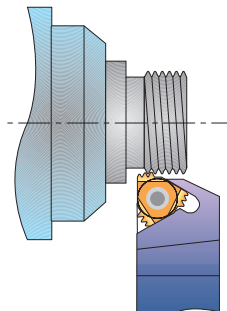

Pitch TPI	L	I.C. in	Number of Teeth	<b>EXTERNAL</b> Ordering Code	Anvil	<b>INTERNAL</b> Ordering Code	Anvil	X	Y
11.5	22	1/2	2	<b>22 ER 11.5 NPTF 2M</b>	AE22M	<b>22 IR 11.5 NPTF 2M</b>	AI22M	2.3	3.5

## BSPT

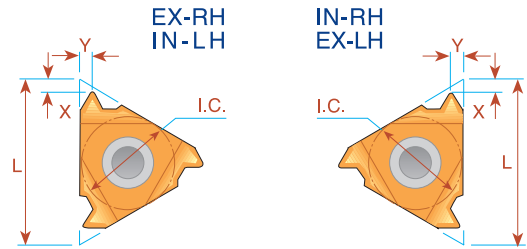
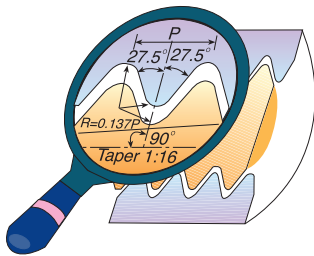

Pitch TPI	L	I.C. in	<b>EXTERNAL</b>		<b>INTERNAL</b>		X	Y
			Ordering Code Right Hand	Ordering Code Left Hand	Ordering Code Right Hand	Ordering Code Left Hand		
28	6	5/32	<i>ULTRA MINIATURE</i> →		<b>*06 IR 28 BSPT</b>	<b>*06 IL 28 BSPT</b>	0.7	0.6
28	8	3/16			<b>*08 IR 28 BSPT</b>	<b>*08 IL 28 BSPT</b>	0.6	0.6
19	8	3/16	<i>MINIATURE</i> →		<b>*08 IR 19 BSPT</b>	<b>*08 IL 19 BSPT</b>	0.6	0.6
28	11	1/4			<b>11 IR 28 BSPT</b>	<b>11 IL 28 BSPT</b>	0.6	0.6
19	11	1/4			<b>11 IR 19 BSPT</b>	<b>11 IL 19 BSPT</b>	0.8	0.9
14	11	1/4			<b>11 IR 14 BSPT</b>	<b>11 IL 14 BSPT</b>	0.9	1.0
11	11	1/4			<sup>(1)</sup> <b>11 IR 11 BSPT</b>	<sup>(1)</sup> <b>11 IL 11 BSPT</b>	0.9	1.2
28	16	3/8	<b>16 ER 28 BSPT</b>	<b>16 EL 28 BSPT</b>	<b>16 IR 28 BSPT</b>	<b>16 IL 28 BSPT</b>	0.6	0.6
19	16	3/8	<b>16 ER 19 BSPT</b>	<b>16 EL 19 BSPT</b>	<b>16 IR 19 BSPT</b>	<b>16 IL 19 BSPT</b>	0.8	0.9
14	16	3/8	<b>16 ER 14 BSPT</b>	<b>16 EL 14 BSPT</b>	<b>16 IR 14 BSPT</b>	<b>16 IL 14 BSPT</b>	1.0	1.2
11	16	3/8	<b>16 ER 11 BSPT</b>	<b>16 EL 11 BSPT</b>	<b>16 IR 11 BSPT</b>	<b>16 IL 11 BSPT</b>	1.1	1.5

Order example: 11 IR 14 BSPT BMA

\* Available only in BXC and BMA grades

(1) Special holder is required or standard holder can be amended by customer.

## Type B

### Ground Profile with Sintered Chip-breaker

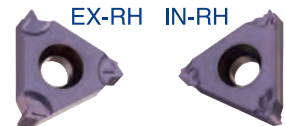

Pitch TPI	L	I.C. in	<b>EXTERNAL</b>		<b>INTERNAL</b>		X	Y
			Ordering Code Right Hand	Ordering Code Right Hand	Ordering Code Right Hand	Ordering Code Right Hand		
19	11	1/4			<b>11 IR B 19 BSPT</b>		0.8	0.9
19	16	3/8	<b>16 ER B 19 BSPT</b>				1.0	1.1
14	16	3/8	<b>16 ER B 14 BSPT</b>		<b>16 IR B 14 BSPT</b>		1.2	1.0
11	16	3/8	<b>16 ER B 11 BSPT</b>		<b>16 IR B 11 BSPT</b>		1.5	1.1

Order example: 16 ER B 11BSPT BMA

For Carbide Grade and Cutting Speed see page 60-61

## BSPT Vertical

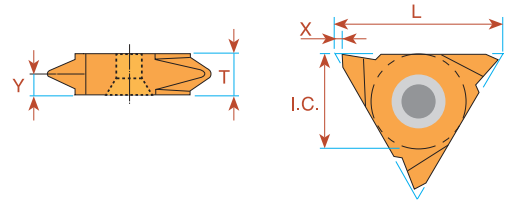

Pitch TPI	L	I.C. in	<b>EXTERNAL</b>	<b>EXTERNAL</b>	X	Y	T
			Ordering Code Right Hand	Ordering Code Left Hand			
28	16	3/8	<b>16V ER 28 BSPT</b>	<b>16V EL 28 BSPT</b>	1.0	0.6	3.6
19	16	3/8	<b>16V ER 19 BSPT</b>	<b>16V EL 19 BSPT</b>	1.0	0.9	3.6
14	16	3/8	<b>16V ER 14 BSPT</b>	<b>16V EL 14 BSPT</b>	1.0	1.2	3.6
11	16	3/8	<b>16V ER 11 BSPT</b>	<b>16V EL 11 BSPT</b>	1.0	1.5	3.6

Order example: 16V ER 19 BSPT BMA

## DIN 477

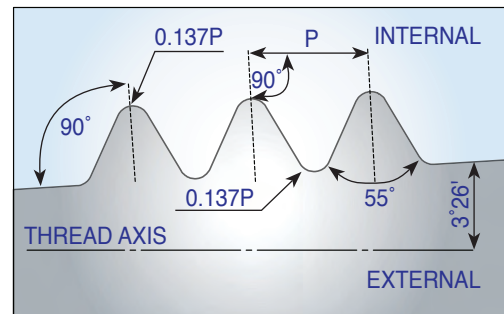

Pitch TPI	L	I.C. in	Taper Ratio	<b>EXTERNAL</b>	<b>INTERNAL</b>	X	Y	Thread Designation
				Ordering Code Right Hand	Ordering Code Right Hand			
14	16	3/8	3/25	<b>16 ER 14 DIN477</b>		1.0	1.2	W19.8x1/14 keg(Ext.)
14	11	1/4	3/25		<b>*11 IR 14 DIN477</b>	0.9	1.0	W19.8x1/14 keg(Int.)
14	16	3/8	3/25	<b>16 ER 14 DIN477</b>	<b>**16 IR 14 DIN477</b>	1.0	1.2	W28.8x1/14 keg
14	16	3/8	3/25	<b>16 ER 14 DIN477</b>	<b>***16 IR 14 DIN477</b>	1.0	1.2	W31.3x1/14 keg

\* Holder to use: SIR0010H11/SIR0010K11

\*\* Holder to use: SIR0016P16

\*\*\* Holder to use: SIR0020P16

For Carbide Grade and Cutting Speed see page 60-61

## Acme

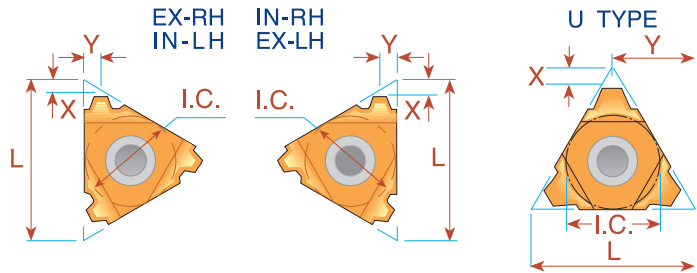
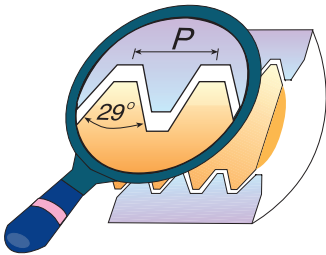

Pitch TPI	L	I.C. in	<b>EXTERNAL</b>		<b>INTERNAL</b>		X	Y
			Right Hand	Left Hand	Right Hand	Left Hand		
16	8	3/16	Ordering Code		Ordering Code			
			Right Hand	Left Hand	Right Hand	Left Hand		
16	8	3/16	MINIATURE		**08 IR 16 ACME	**08 IL 16 ACME	0.6	0.6
14	8U	3/16U	"U" MINIATURE		*08U IR/L 14 ACME		0.8	4.0
12	8U	3/16U			*08U IR/L 12 ACME		0.8	4.0
10	8U	3/16U			*08U IR/L 10 ACME		0.8	4.0
16	11	1/4	11 ER 16 ACME	11 EL 16 ACME	11 IR 16 ACME	11 IL 16 ACME	0.9	1.0
16	16	3/8	16 ER 16 ACME	16 EL 16 ACME	16 IR 16 ACME	16 IL 16 ACME	0.9	1.0
14	16	3/8	16 ER 14 ACME	16 EL 14 ACME	16 IR 14 ACME	16 IL 14 ACME	1.0	1.2
12	16	3/8	16 ER 12 ACME	16 EL 12 ACME	16 IR 12 ACME	16 IL 12 ACME	1.1	1.2
10	16	3/8	16 ER 10 ACME	16 EL 10 ACME	16 IR 10 ACME	16 IL 10 ACME	1.3	1.3
8	16	3/8	16 ER 8 ACME	16 EL 8 ACME	16 IR 8 ACME	16 IL 8 ACME	1.5	1.5
6	16	3/8	(1) 16 ER 6 ACME	(1) 16 EL 6 ACME	(1) 16 IR 6 ACME	(1) 16 IL 6 ACME	1.7	1.8
6	22	1/2	22 ER 6 ACME	22 EL 6 ACME	22 IR 6 ACME	22 IL 6 ACME	1.8	2.1
5	22	1/2	22 ER 5 ACME	22 EL 5 ACME	22 IR 5 ACME	22 IL 5 ACME	2.0	2.3
4	22	1/2	(1) 22 ER 4 ACME	(1) 22 EL 4 ACME	(1) 22 IR 4 ACME	(1) 22 IL 4 ACME	2.1	2.2
4	22U	1/2U	22U ER/L 4 ACME		22U IR/L 4 ACME		2.3	11.0
4	27	5/8	27 ER 4 ACME	27 EL 4 ACME	27 IR 4 ACME	27 IL 4 ACME	2.3	2.7
3	27U	5/8U	27U ER/L 3 ACME		27U IR/L 3 ACME		2.8	13.7
2	33U	3/4U	33U ER/L 2 ACME		33U IR/L 2 ACME		4.3	16.9

Order example: 16 ER 16 ACME MXC

\* Available only in BXC and BMA grades

\*\* One cutting edge

(1) Special holder is required or standard holder can be amended by customer.

## Acme Vertical

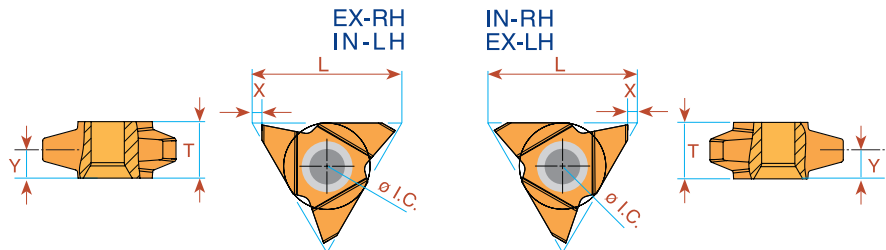

Pitch TPI	L	I.C. in	<b>EXTERNAL</b>		X	Y	T	<b>INTERNAL</b>		X	Y	T
			Right Hand	Left Hand				Right Hand	Left Hand			
* 3.5	27	5/8	27V ER 3.5 ACME		1.8	5.0	10.4	27V IR 3.5 ACME		1.8	4.0	10.4
* 3	27	5/8	27V ER 3 ACME		1.8	5.0	10.4	27V IR 3 ACME		1.8	4.6	10.4
** 2	27	5/8	27V ER 2 ACME	27V EL 2 ACME	1.8	5.0	10.4	27V IR 2 ACME	27V IL 2 ACME	1.8	5.0	10.4

Order example: 27V ER 2 ACME BMA

\* Minimum bore: Ø55 mm \*\* Minimum bore: Ø76 mm

For Carbide Grade and Cutting Speed see page 60-61

## Stub Acme

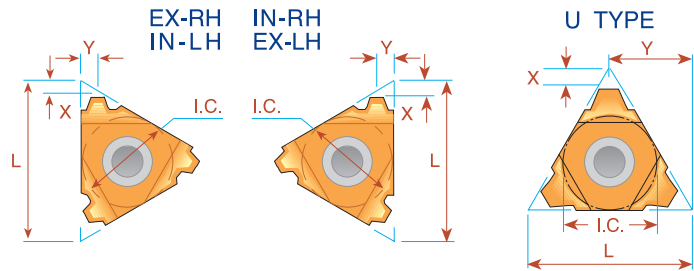
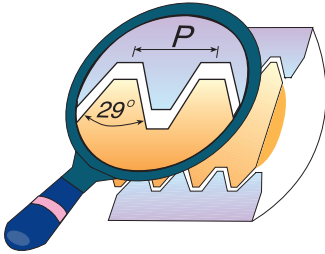

Pitch TPI	L	I.C. in	<b>EXTERNAL</b>		<b>INTERNAL</b>		X	Y
			Ordering Code Right Hand	Ordering Code Left Hand	Ordering Code Right Hand	Ordering Code Left Hand		
16	8	3/16	<i>MINIATURE</i> →		<b>**08 IR 16 STACME</b>	<b>**08 IL 16 STACME</b>	0.6	0.6
14	8U	3/16U	<i>"U" MINIATURE</i> →		<b>*08U IR/L 14 STACME</b>		0.8	4.0
12	8U	3/16U			<b>*08U IR/L 12 STACME</b>		0.9	4.0
10	8U	3/16U			<b>*08U IR/L 10 STACME</b>		1.0	4.0
16	11	1/4	<b>11 ER 16 STACME</b>	<b>11 EL 16 STACME</b>			1.0	1.0
16	16	3/8	<b>16 ER 16 STACME</b>	<b>16 EL 16 STACME</b>	<b>16 IR 16 STACME</b>	<b>16 IL 16 STACME</b>	1.0	1.0
14	16	3/8	<b>16 ER 14 STACME</b>	<b>16 EL 14 STACME</b>	<b>16 IR 14 STACME</b>	<b>16 IL 14 STACME</b>	1.1	1.1
12	16	3/8	<b>16 ER 12 STACME</b>	<b>16 EL 12 STACME</b>	<b>16 IR 12 STACME</b>	<b>16 IL 12 STACME</b>	1.2	1.2
10	16	3/8	<b>16 ER 10 STACME</b>	<b>16 EL 10 STACME</b>	<b>16 IR 10 STACME</b>	<b>16 IL 10 STACME</b>	1.3	1.3
8	16	3/8	<b>16 ER 8 STACME</b>	<b>16 EL 8 STACME</b>	<b>16 IR 8 STACME</b>	<b>16 IL 8 STACME</b>	1.5	1.5
6	16	3/8	<b>16 ER 6 STACME</b>	<b>16 EL 6 STACME</b>	<b>16 IR 6 STACME</b>	<b>16 IL 6 STACME</b>	1.8	1.8
5	22	1/2	<b>22 ER 5 STACME</b>	<b>22 EL 5 STACME</b>	<b>22 IR 5 STACME</b>	<b>22 IL 5 STACME</b>	2.0	2.3
4	22	1/2	<b>22 ER 4 STACME</b>	<b>22 EL 4 STACME</b>	<b>22 IR 4 STACME</b>	<b>22 IL 4 STACME</b>	2.3	2.4
4	22U	1/2U	<b>22U ER/L 4 STACME</b>		<b>22U IR/L 4 STACME</b>		2.5	11.0
3	22U	1/2U	<b>22U ER/L 3 STACME</b>		<b>22U IR/L 3 STACME</b>		3.3	11.0
4	27	5/8	<b>27 ER 4 STACME</b>	<b>27 EL 4 STACME</b>	<b>27 IR 4 STACME</b>	<b>27 IL 4 STACME</b>	2.3	2.4
3	27	5/8	<b>27 ER 3 STACME</b>	<b>27 EL 3 STACME</b>	<b>27 IR 3 STACME</b>	<b>27 IL 3 STACME</b>	2.8	2.9
2	33U	3/4U	<b>33U ER/L 2 STACME</b>		<b>33U IR/L 2 STACME</b>		5.0	16.9

Order example: 22 IR 5 STACME MXC

\* Available only in BXC and BMA grades

\*\* One cutting edge

For Carbide Grade and Cutting Speed see page 60-61



## Trapez - DIN 103

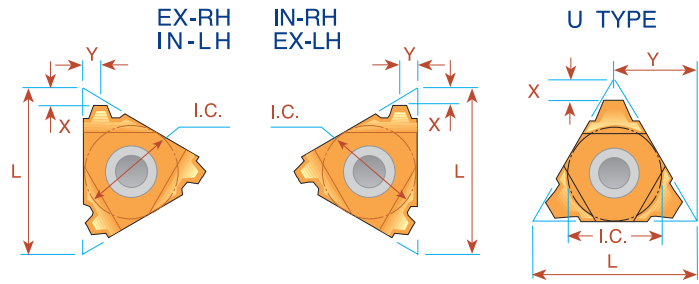
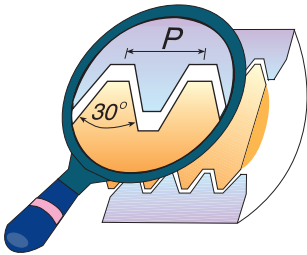

Pitch mm	L	I.C. in	EXTERNAL Ordering Code		INTERNAL Ordering Code		X	Y
			Right Hand	Left Hand	Right Hand	Left Hand		
1.5	8	3/16	MINIATURE →		**08 IR 1.5 TR	**08 IL 1.5 TR	0.6	0.6
2.0	8U	3/16U	"U" MINIATURE →		*08U IR/L 2 TR		0.9	4.0
1.5	16	3/8	16 ER 1.5 TR	16 EL 1.5 TR	16 IR 2 TR	16 IL 2 TR	1.0	1.1
2.0	16	3/8	16 ER 2 TR	16 EL 2 TR			1.0	1.3
3.0	16	3/8	16 ER 3 TR	16 EL 3 TR	16 IR 3 TR	16 IL 3 TR	1.3	1.5
4.0	16	3/8	(1) 16 ER 4 TR	(1) 16 EL 4 TR	(2) 16 IR 4 TR	(2) 16 IL 4 TR	1.3	1.5
5.0	16	3/8U			***16U IR/L 5 TR		2.3	8.2
4.0	22	1/2	22 ER 4 TR	22 EL 4 TR	22 IR 4 TR	22 IL 4 TR	1.8	1.9
5.0	22	1/2	22 ER 5 TR	22 EL 5 TR	22 IR 5 TR	22 IL 5 TR	2.0	2.4
6.0	22	1/2	(1) 22 ER 6 TR	(1) 22 EL 6 TR	(1) 22 IR 6 TR	(1) 22 IL 6 TR	2.0	2.4
6.0	22U	1/2U	22U ER/L 6 TR		22U IR/L 6 TR		2.0	11.0
7.0	22U	1/2U	22U ER/L 7 TR		22U IR/L 7 TR		2.3	11.0
(3) 7.0	22U	1/2U			(3) 22U IR/L 7 TR40		2.6	11.0
8.0	22U	1/2U	22U ER/L 8 TR		22U IR/L 8 TR		2.5	11.0
6.0	27	5/8	27 ER 6 TR	27 EL 6 TR	27 IR 6 TR	27 IL 6 TR	2.3	2.7
7.0	27	5/8	27 ER 7 TR	27 EL 7 TR	27 IR 7 TR	27 IL 7 TR	2.2	2.6
8.0	27U	5/8U	27U ER/L 8 TR		27U IR/L 8 TR		2.5	13.7
9.0	27U	5/8U	27U ER/L 9 TR		27U IR/L 9 TR		3.0	13.7
10.0	27U	5/8U	**27U ER/L 10 TR		**27U IR/L 10 TR		3.2	13.7
12.0	33U	3/4U	33U ER/L 12 TR		33U IR/L 12 TR		3.9	16.9

Order example: 22 IR 5 TR MXC

\* Available only in BXC and BMA grades

\*\* One cutting edge

\*\*\* To be used only with holder SIR/L0014M16UB on page 47

(1) Special holder is required or standard holder can be amended by customer.

(2) Special holder is required or standard holder can be amended by customer or to used with holders: SIR/L0012L16B; SIR/L0014L16B

(3) Only for Tr 40 x 7.0. To be used only with holder SIR/L0025S22UB

## Trapez - DIN 103 Vertical

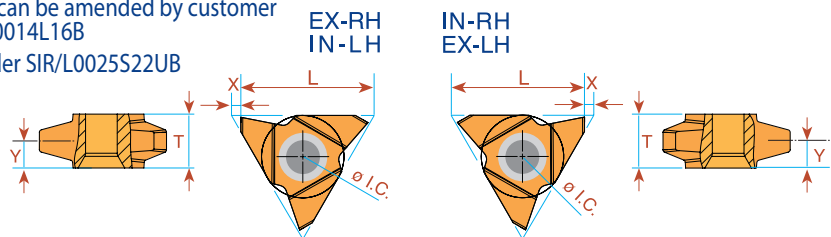

Pitch mm	L	I.C. in	EXTERNAL Ordering Code		INTERNAL Ordering Code		X	Y	T
			Right Hand	Left Hand	Right Hand	Left Hand			
* 9	27	5/8	27V ER 9 TR	27V EL 9 TR	27V IR 9 TR	27V IL 9 TR	1.8	5.2	10.4
* 10	27	5/8	27V ER 10 TR	27V EL 10 TR	27V IR 10 TR	27V IL 10 TR	1.8	5.2	10.4
** 12	27	5/8	27V ER 12 TR	27V EL 12 TR	27V IR 12 TR	27V IL 12 TR	1.8	5.2	10.4

Order example: 27V ER 10 TR BMA

\* Minimum bore: Ø65 mm \*\* Minimum bore: Ø73 mm

For Carbide Grade and Cutting Speed see page 60-61

## PG - DIN 40430

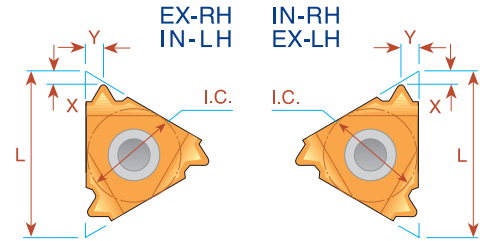
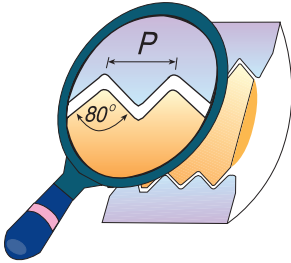

Pitch TPI	L	I.C. in	EXTERNAL		INTERNAL		X	Y
			Right Hand	Standard	Right Hand	Standard		
20	8	3/16	MINIATURE →		*08 IR 20 PG	(PG 7)	0.6	0.7
18	11	1/4			11 IR 18 PG	(PG 9)	0.8	0.9
20	16	3/8	16 ER 20 PG	(PG 7)	16 IR 18 PG	(PG 11, 13.5, 16)	0.7	0.8
18	16	3/8	16 ER 18 PG	(PG 9, 11, 13.5, 16)	16 IR 18 PG	(PG 11, 13.5, 16)	0.8	0.9
16	16	3/8	16 ER 16 PG	(PG 21, 29, 36, 42, 48)	16 IR 16 PG	(PG 21, 29, 36, 42, 48)	0.8	1.0

Order example: 16 ER 16 PG BMA

\* Available only in BXC and BMA grades

## Sagengewinde- DIN 513

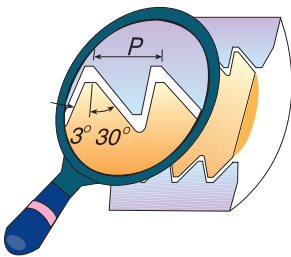

**IMPORTANT NOTE:**  
In Carmex standard execution, the flank with the large angle is the leading edge. If otherwise required, please specify in your order.

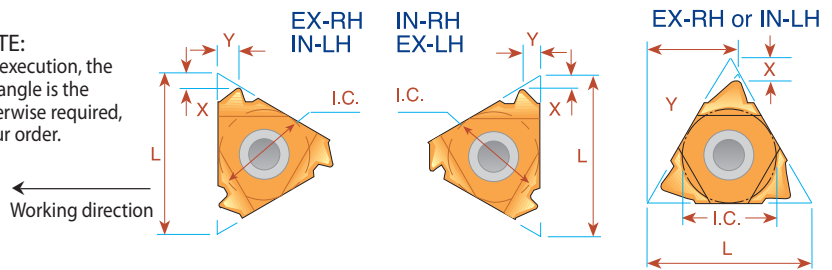

Pitch mm	L	I.C. in	EXTERNAL		X	Y	INTERNAL		X	Y
			Right Hand	Left Hand			Right Hand	Left Hand		
2.0	16	3/8	16 ER 2 SAGE	16 EL 2 SAGE	1.1	1.6	16 IR 2 SAGE	16 IL 2 SAGE	1.2	1.7
3.0	22	1/2	22 ER 3 SAGE	22 EL 3 SAGE	1.5	2.4	22 IR 3 SAGE	22 IL 3 SAGE	1.9	2.9
4.0	22	1/2	22 ER 4 SAGE	22 EL 4 SAGE	1.9	3.1	22 IR 4 SAGE	22 IL 4 SAGE	2.3	3.5
*5.0	22U	1/2U	22U ER 5 SAGE	22U EL 5 SAGE	1.2	11.6	22U IR 5 SAGE	22U IL 5 SAGE	1.9	11.7
*6.0	22U	1/2U	22U ER 6 SAGE	22U EL 6 SAGE	1.2	11.7	22U IR 6 SAGE	22U IL 6 SAGE	2.1	11.9

Order example: 22 IR 4 SAGE BMA

\* Requires a special anvil AER 22U-1.5 SAGE 5/6, AEL 22U-1.5 SAGE 5/6, AIR 22U-1.5 SAGE 5/6, AIL 22U-1.5 SAGE 5/6.

For Carbide Grade and Cutting Speed see page 60-61

## Round - DIN 405

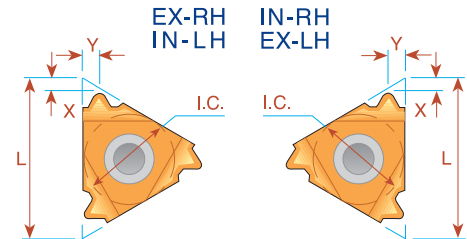
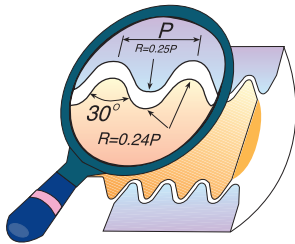

Pitch TPI	L	I.C. in	<b>EXTERNAL</b>		X	Y	<b>INTERNAL</b>		X	Y
			Ordering Code Right Hand	Ordering Code Left Hand			Ordering Code Right Hand	Ordering Code Left Hand		
10	16	3/8	<b>16 ER 10 RD</b>	<b>16 EL 10 RD</b>	1.1	1.2	<b>16 IR 10 RD</b>	<b>16 IL 10 RD</b>	1.1	1.2
8	16	3/8	<b>16 ER 8 RD</b>	<b>16 EL 8 RD</b>	1.4	1.3	<b>16 IR 8 RD</b>	<b>16 IL 8 RD</b>	1.4	1.4
6	16	3/8	<b>16 ER 6 RD</b>	<b>16 EL 6 RD</b>	1.5	1.7	<b>16 IR 6 RD</b>	<b>16 IL 6 RD</b>	1.4	1.5
6	22	1/2	<b>22 ER 6 RD</b>	<b>22 EL 6 RD</b>	1.5	1.7	<b>22 IR 6 RD</b>	<b>22 IL 6 RD</b>	1.5	1.7
4	22	1/2	<b>22 ER 4 RD</b>	<b>22 EL 4 RD</b>	2.2	2.3	<b>22 IR 4 RD</b>	<b>22 IL 4 RD</b>	2.2	2.3
4	27	5/8	<b>27 ER 4 RD</b>	<b>27 EL 4 RD</b>	2.2	2.3	<b>27 IR 4 RD</b>	<b>27 IL 4 RD</b>	2.2	2.3

Order example: 27 IL 4 RD BMA

## Round - DIN 20400

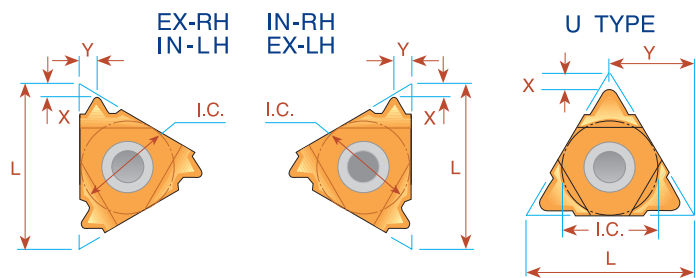
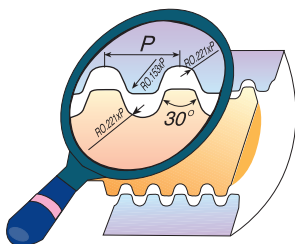

Pitch mm	L	I.C. in	<b>EXTERNAL</b>	<b>INTERNAL</b>	X	Y
			Ordering Code Right Hand	Ordering Code Right Hand		
4.0	22	1/2	<b>22 ER 4.0 RD 20400</b>	<b>22 IR 4.0 RD 20400</b>	1.4	1.4
5.0	22	1/2	<b>22 ER 5.0 RD 20400</b>	<b>22 IR 5.0 RD 20400</b>	1.7	1.8
6.0	22	1/2	<b>22 ER 6.0 RD 20400</b>	<b>22 IR 6.0 RD 20400</b>	1.7	2.0
8.0	27U	5/8U	<b>*27U - 8.0 RD 20400</b>		3.0	13.7
10.0	27U	5/8U	<b>*27U - 10.0 RD 20400</b>		3.4	13.7

Order example: 22 ER 4.0 RD 20400 MXC

\* Same insert for Internal and External Right Hand Thread

For Carbide Grade and Cutting Speed see page 60-61

## UNJ UNJC, UNJF, UNJEF, UNJS

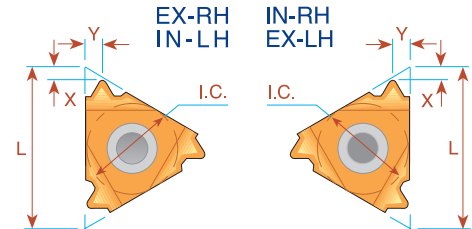
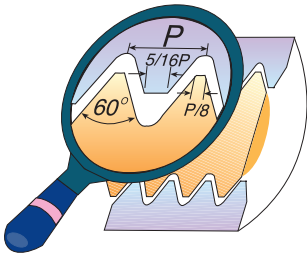

Pitch TPI	L	I.C. in	<b>EXTERNAL</b>		<b>INTERNAL</b>		X	Y
			Right Hand	Left Hand	Right Hand	Left Hand		
48	11	1/4	<b>11 ER 48 UNJ</b>	<b>11 EL 48 UNJ</b>	<b>11 IR 48 UNJ</b>	<b>11 IL 48 UNJ</b>	0.6	0.6
44	11	1/4	<b>11 ER 44 UNJ</b>	<b>11 EL 44 UNJ</b>	<b>11 IR 44 UNJ</b>	<b>11 IL 44 UNJ</b>	0.6	0.6
40	11	1/4	<b>11 ER 40 UNJ</b>	<b>11 EL 40 UNJ</b>	<b>11 IR 40 UNJ</b>	<b>11 IL 40 UNJ</b>	0.6	0.6
36	11	1/4	<b>11 ER 36 UNJ</b>	<b>11 EL 36 UNJ</b>	<b>11 IR 36 UNJ</b>	<b>11 IL 36 UNJ</b>	0.6	0.6
32	11	1/4	<b>11 ER 32 UNJ</b>	<b>11 EL 32 UNJ</b>	<b>11 IR 32 UNJ</b>	<b>11 IL 32 UNJ</b>	0.6	0.6
28	11	1/4	<b>11 ER 28 UNJ</b>	<b>11 EL 28 UNJ</b>	<b>11 IR 28 UNJ</b>	<b>11 IL 28 UNJ</b>	0.6	0.6
24	11	1/4	<b>11 ER 24 UNJ</b>	<b>11 EL 24 UNJ</b>	<b>11 IR 24 UNJ</b>	<b>11 IL 24 UNJ</b>	0.7	0.8
20	11	1/4	<b>11 ER 20 UNJ</b>	<b>11 EL 20 UNJ</b>	<b>11 IR 20 UNJ</b>	<b>11 IL 20 UNJ</b>	0.8	0.9
18	11	1/4	<b>11 ER 18 UNJ</b>	<b>11 EL 18 UNJ</b>	<b>11 IR 18 UNJ</b>	<b>11 IL 18 UNJ</b>	0.8	1.0
16	11	1/4	<b>11 ER 16 UNJ</b>	<b>11 EL 16 UNJ</b>	<b>11 IR 16 UNJ</b>	<b>11 IL 16 UNJ</b>	0.8	1.0
14	11	1/4	<b>11 ER 14 UNJ</b>	<b>11 EL 14 UNJ</b>	<b>11 IR 14 UNJ</b>	<b>11 IL 14 UNJ</b>	0.9	1.0
48	16	3/8	<b>16 ER 48 UNJ</b>	<b>16 EL 48 UNJ</b>	<b>16 IR 48 UNJ</b>	<b>16 IL 48 UNJ</b>	0.6	0.6
44	16	3/8	<b>16 ER 44 UNJ</b>	<b>16 EL 44 UNJ</b>	<b>16 IR 44 UNJ</b>	<b>16 IL 44 UNJ</b>	0.6	0.6
40	16	3/8	<b>16 ER 40 UNJ</b>	<b>16 EL 40 UNJ</b>	<b>16 IR 40 UNJ</b>	<b>16 IL 40 UNJ</b>	0.6	0.6
36	16	3/8	<b>16 ER 36 UNJ</b>	<b>16 EL 36 UNJ</b>	<b>16 IR 36 UNJ</b>	<b>16 IL 36 UNJ</b>	0.6	0.6
32	16	3/8	<b>16 ER 32 UNJ</b>	<b>16 EL 32 UNJ</b>	<b>16 IR 32 UNJ</b>	<b>16 IL 32 UNJ</b>	0.6	0.6
28	16	3/8	<b>16 ER 28 UNJ</b>	<b>16 EL 28 UNJ</b>	<b>16 IR 28 UNJ</b>	<b>16 IL 28 UNJ</b>	0.6	0.6
24	16	3/8	<b>16 ER 24 UNJ</b>	<b>16 EL 24 UNJ</b>	<b>16 IR 24 UNJ</b>	<b>16 IL 24 UNJ</b>	0.7	0.8
20	16	3/8	<b>16 ER 20 UNJ</b>	<b>16 EL 20 UNJ</b>	<b>16 IR 20 UNJ</b>	<b>16 IL 20 UNJ</b>	0.8	0.9
18	16	3/8	<b>16 ER 18 UNJ</b>	<b>16 EL 18 UNJ</b>	<b>16 IR 18 UNJ</b>	<b>16 IL 18 UNJ</b>	0.8	1.0
16	16	3/8	<b>16 ER 16 UNJ</b>	<b>16 EL 16 UNJ</b>	<b>16 IR 16 UNJ</b>	<b>16 IL 16 UNJ</b>	0.8	1.0
14	16	3/8	<b>16 ER 14 UNJ</b>	<b>16 EL 14 UNJ</b>	<b>16 IR 14 UNJ</b>	<b>16 IL 14 UNJ</b>	1.0	1.2
13	16	3/8	<b>16 ER 13 UNJ</b>	<b>16 EL 13 UNJ</b>	<b>16 IR 13 UNJ</b>	<b>16 IL 13 UNJ</b>	1.0	1.3
12	16	3/8	<b>16 ER 12 UNJ</b>	<b>16 EL 12 UNJ</b>	<b>16 IR 12 UNJ</b>	<b>16 IL 12 UNJ</b>	1.1	1.4
11	16	3/8	<b>16 ER 11 UNJ</b>	<b>16 EL 11 UNJ</b>	<b>16 IR 11 UNJ</b>	<b>16 IL 11 UNJ</b>	1.1	1.5
10	16	3/8	<b>16 ER 10 UNJ</b>	<b>16 EL 10 UNJ</b>	<b>16 IR 10 UNJ</b>	<b>16 IL 10 UNJ</b>	1.1	1.5
9	16	3/8	<b>16 ER 9 UNJ</b>	<b>16 EL 9 UNJ</b>	<b>16 IR 9 UNJ</b>	<b>16 IL 9 UNJ</b>	1.2	1.6
8	16	3/8	<b>16 ER 8 UNJ</b>	<b>16 EL 8 UNJ</b>	<b>16 IR 8 UNJ</b>	<b>16 IL 8 UNJ</b>	1.2	1.6

Order example: 16 IR 16 UNJ MXC

For Carbide Grade and Cutting Speed see page 60-61

## UNJ UNJC, UNJF, UNJEF, UNJS

### Type B

#### Ground Profile with Sintered Chip-breaker

Pitch TPI	L	I.C. in	<b>INTERNAL</b> Ordering Code Right Hand	X	Y
32	11	1/4	<b>11 IR B 32 UNJ</b>	0.6	0.6
28	11	1/4	<b>11 IR B 28 UNJ</b>	0.6	0.6
24	11	1/4	<b>11 IR B 24 UNJ</b>	0.6	0.6
20	11	1/4	<b>11 IR B 20 UNJ</b>	0.8	0.9
18	11	1/4	<b>11 IR B 18 UNJ</b>	0.8	0.9
16	11	1/4	<b>11 IR B 16 UNJ</b>	0.8	0.9
14	11	1/4	<b>11 IR B 14 UNJ</b>	0.8	0.9



Order example: 11 IR B 20 UNJ BMA

### Multitooth

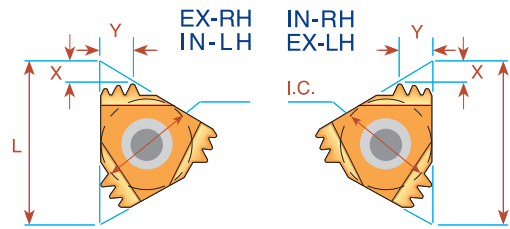
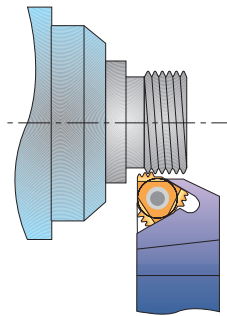

Pitch TPI	L	I.C. in	Number of Teeth	<b>EXTERNAL</b> Ordering Code	Anvil	<b>INTERNAL</b> Ordering Code	Anvil	X	Y
16	16	3/8	2	<b>16 ER 16 UNJ 2M</b>	AE16M	-	-	1.6	2.4
16	22	1/2	3	<b>22 ER 16 UNJ 2M</b>	AE22M	-	-	2.3	3.8

Order example: 22 ER 16 UNJ 2M BMA

For Carbide Grade and Cutting Speed see page 60-61

## MJ - ISO 5855

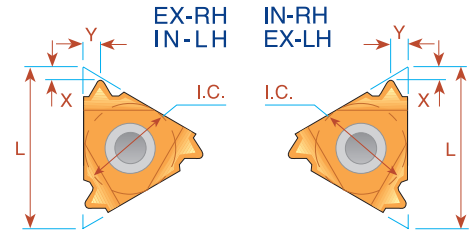
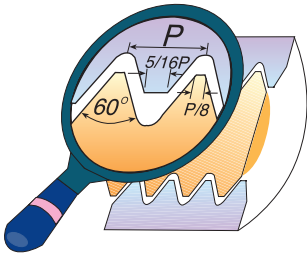

Pitch mm	L	I.C. in	<b>EXTERNAL</b>	<b>INTERNAL</b>	X	Y
			Ordering Code Right Hand	Ordering Code Right Hand		
1.0	11	1/4		<b>11 IR 1.0 MJ</b>	0.7	0.8
1.25	11	1/4		<b>11 IR 1.25 MJ</b>	0.8	0.9
1.5	11	1/4		<b>11 IR 1.5 MJ</b>	0.8	1.0
2.0	11	1/4		<b>11 IR 2.0 MJ</b>	0.9	1.0
1.0	16	3/8	<b>16 ER 1.0 MJ</b>	<b>16 IR 1.0 MJ</b>	0.7	0.8
1.25	16	3/8	<b>16 ER 1.25 MJ</b>	<b>16 IR 1.25 MJ</b>	0.8	0.9
1.5	16	3/8	<b>16 ER 1.5 MJ</b>	<b>16 IR 1.5 MJ</b>	0.8	1.0
2.0	16	3/8	<b>16 ER 2.0 MJ</b>	<b>16 IR 2.0 MJ</b>	1.0	1.3

Order example: 16 ER 1.5 MJ BMA

## Type B

### Ground Profile with Sintered Chip-breaker

Pitch mm	L	I.C. in	<b>INTERNAL</b>	X	Y
			Ordering Code Right Hand		
1.0	11	1/4	<b>11 IR B 1.0 MJ</b>	0.6	0.6
1.5			<b>11 IR B 1.5 MJ</b>	0.8	0.9



Order example: 11 IR B 1.5 MJ BMA

For Carbide Grade and Cutting Speed see page 60-61

## American Buttress

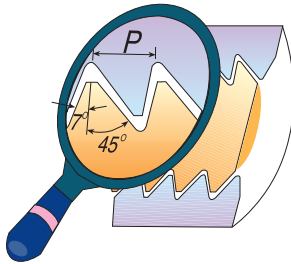

**IMPORTANT NOTE:**  
In Carmex standard execution, the flank with the large angle is the leading edge. If otherwise required, please specify in your order.

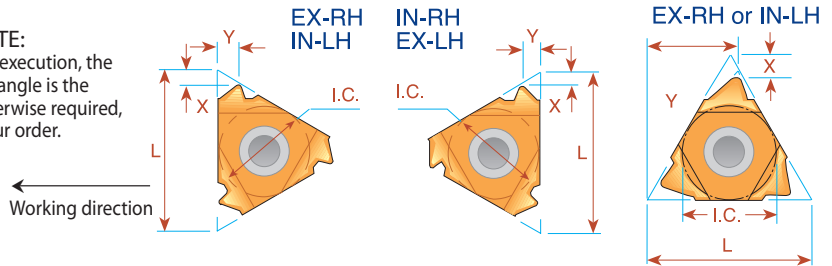

Pitch TPI	L	I.C. in	<b>EXTERNAL</b>		<b>INTERNAL</b>		X	Y
			Ordering Code Right Hand	Ordering Code Left Hand	Ordering Code Right Hand	Ordering Code Left Hand		
20	11	1/4	<b>11 ER 20 ABUT</b>	<b>11 EL 20 ABUT</b>	<b>11 IR 20 ABUT</b>	<b>11 IL 20 ABUT</b>	1.0	1.3
16	11	1/4	<b>11 ER 16 ABUT</b>	<b>11 EL 16 ABUT</b>	<b>11 IR 16 ABUT</b>	<b>11 IL 16 ABUT</b>	1.0	1.5
20	16	3/8	<b>16 ER 20 ABUT</b>	<b>16 EL 20 ABUT</b>	<b>16 IR 20 ABUT</b>	<b>16 IL 20 ABUT</b>	1.0	1.3
16	16	3/8	<b>16 ER 16 ABUT</b>	<b>16 EL 16 ABUT</b>	<b>16 IR 16 ABUT</b>	<b>16 IL 16 ABUT</b>	1.0	1.5
12	16	3/8	<b>16 ER 12 ABUT</b>	<b>16 EL 12 ABUT</b>	<b>16 IR 12 ABUT</b>	<b>16 IL 12 ABUT</b>	1.4	2.0
10	16	3/8	<b>16 ER 10 ABUT</b>	<b>16 EL 10 ABUT</b>	<b>16 IR 10 ABUT</b>	<b>16 IL 10 ABUT</b>	1.5	2.3
8	22	1/2	<b>22 ER 8 ABUT</b>	<b>22 EL 8 ABUT</b>	<b>22 IR 8 ABUT</b>	<b>22 IL 8 ABUT</b>	2.1	3.3
6	22	1/2	<b>22 ER 6 ABUT</b>	<b>22 EL 6 ABUT</b>	<b>22 IR 6 ABUT</b>	<b>22 IL 6 ABUT</b>	2.1	3.4
4	22U	1/2U	<b>22U ER 4 ABUT</b>	<b>22U EL 4 ABUT</b>	<b>22U IR 4 ABUT</b>	<b>22U IL 4 ABUT</b>	2.3	9.5
3	27U	5/8U	<b>27U ER 3 ABUT</b>	<b>27U EL 3 ABUT</b>	<b>27U IR 3 ABUT</b>	<b>27U IL 3 ABUT</b>	3.1	11.7

Order example: 16 IL 12 ABUT MXC

Most applications requires anvil change in toolholder see page 65

## Multitooth

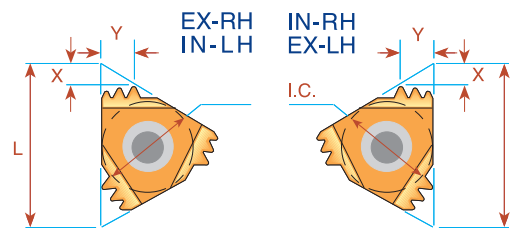
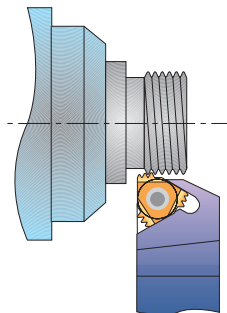

Pitch TPI	L	I.C. in	Number of Teeth	<b>EXTERNAL</b>	Anvil	<b>INTERNAL</b>	Anvil	X	Y
				Ordering Code		Ordering Code			
12	22	1/2	2	<b>22 ER 12 ABUT 2M</b>	AE22M	<b>22 IR 16 ABUT 2M</b>	AI22M	2.5	4.0

Order example: 22 IR 16 ABUT 2M BMA

For Carbide Grade and Cutting Speed see page 60-61

## OIL Threads API Round

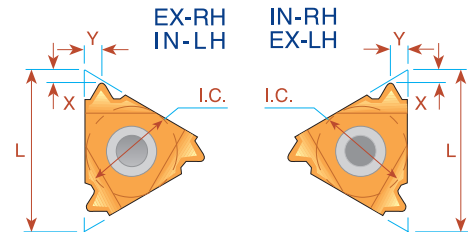
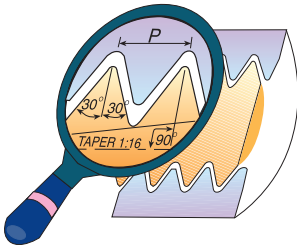

Pitch TPI	L	I.C. in	Taper IPF	<b>EXTERNAL</b> Ordering Code Right Hand	<b>INTERNAL</b> Ordering Code Right Hand	X	Y
10	16	3/8	0.75	<b>16 ER 10 API RD</b>	<b>16 IR 10 API RD</b>	1.5	1.4
8	16	3/8	0.75	<b>16 ER 8 API RD</b>	<b>16 IR 8 API RD</b>	1.3	1.6

## Multitooth

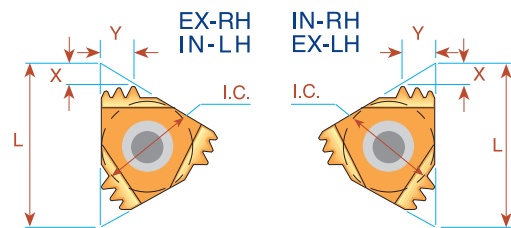
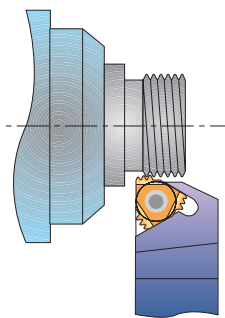

Pitch TPI	L	I.C. in	Number of Teeth	<b>EXTERNAL</b> Ordering Code	Anvil	<b>INTERNAL</b> Ordering Code	Anvil	X	Y
10	22	1/2	2	<b>22 ER 10API RD 2M</b>	AE22M	<b>22 IR 10API RD 2M</b>	AI22M	2.4	3.7
10	27	5/8	3	<b>27 ER 10API RD 3M</b>	AE27M	<b>27 IR 10API RD 3M</b>	AI27M	3.8	6.2
8	27	5/8	2	<b>27 ER 8API RD 2M</b>	AE27M	<b>27 IR 8API RD 2M</b>	AI27M	3.0	4.5

Order example: 27 IR 10 API RD 3M MXC  
For recommended number of passes see page 62

For Carbide Grade and Cutting Speed see page 60-61



## OIL Threads

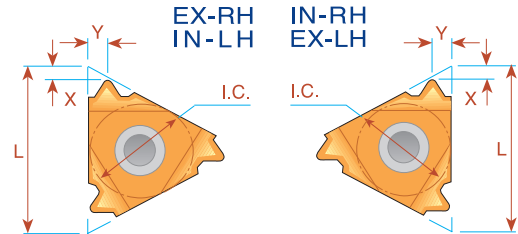
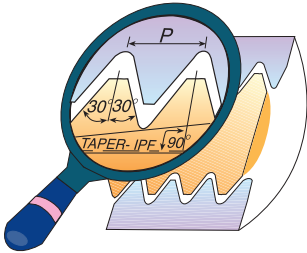

### V-0.040

Pitch TPI	L	I.C. in	Taper IPF	<b>EXTERNAL</b>	<b>INTERNAL</b>	X	Y	Connection No. or Size
				Ordering Code Right Hand	Ordering Code Right Hand			
5	22	1/2	3	<b>22 ER 5 API 403</b>	<b>22 IR 5 API 403</b>	1.8	2.5	23/8-4 1/2 REG

### V-0.038R

Pitch TPI	L	I.C. in	Taper IPF	<b>EXTERNAL</b>	<b>INTERNAL</b>	X	Y	Connection No. or Size
				Ordering Code Right Hand	Ordering Code Right Hand			
4	27	5/8	2	<b>27 ER 4 API 382</b>	<b>27 IR 4 API 382</b>	2.1	2.8	NC23-NC50
4	27	5/8	3	<b>27 ER 4 API 383</b>	<b>27 IR 4 API 383</b>	2.1	2.8	NC56-NC77

### V-0.050

Pitch TPI	L	I.C. in	Taper IPF	<b>EXTERNAL</b>	<b>INTERNAL</b>	X	Y	Connection No. or Size
				Ordering Code Right Hand	Ordering Code Right Hand			
4	27	5/8	2	<b>27 ER 4 API 502</b>	<b>27 IR 4 API 502</b>	2.0	3.0	65/8 REG
4	27	5/8	3	<b>27 ER 4 API 503</b>	<b>27 IR 4 API 503</b>	2.0	3.0	5 1/2, 75/8, 85/8 REG

### V-0.055

Macaroni Tubing (MT)  
 American Macaroni Tubing (AMT)  
 American Mining Macaroni Tubing (AMMT)

Pitch TPI	L	I.C. in	Taper IPF	<b>EXTERNAL</b>	<b>INTERNAL</b>	X	Y	Connection No. or Size
				Ordering Code Right Hand	Ordering Code Right Hand			
6	22	1/2	1.5	<b>22 ER 6 API 551.5</b>	-	2.0	1.7	NC10,NC12,NC13,NC16
6	16	3/8	1.5	-	<b>16 IR 6 API 551.5</b>	2.0	1.7	NC10,NC12,NC13 *
6	22	1/2	1.5	-	<b>22 IR 6 API 551.5</b>	2.0	1.7	NC16 **

\* For NC10,NC12 use holder SIR0016P16CB  
 For NC13 use holders SIR0020P16/SIR0020P16B/SIR0020S16CB

\*\* For NC16 use holder SIR0025R22

For Carbide Grade and Cutting Speed see page 60-61

## OIL Threads Extreme - Line Casing

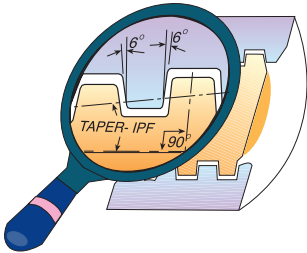

Pitch TPI	L	I.C. in	Taper IPF	<b>EXTERNAL</b>	<b>INTERNAL</b>	X	Y	Connection No. or Size
				Ordering Code Right Hand	Ordering Code Right Hand			
6	22	1/2	1.50	<b>22 ER 6 EL 1.5</b>	<b>22 IR 6 EL 1.5</b>	1.9	1.9	5-7 5/8
5	22	1/2	1.25	<b>22 ER 5 EL 1.25</b>	<b>22 IR 5 EL 1.25</b>	2.4	2.3	8 5/8-10 3/4

## Buttress Casing

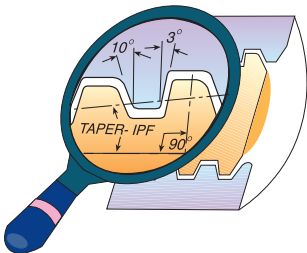

Pitch TPI	L	I.C. in	Taper IPF	<b>EXTERNAL</b>	<b>INTERNAL</b>	X	Y	Connection No. or Size
				Ordering Code Right Hand	Ordering Code Right Hand			
5	22	1/2	0.75	<b>22 ER 5 BUT 0.75</b>	<b>22 IR 5 BUT 0.75</b>	2.2	2.4	4 1/2-13 3/8
5	22	1/2	1.00	<b>22 ER 5 BUT 1.0</b>	<b>22 IR 5 BUT 1.0</b>	2.3	2.4	16-20

Order example: 22 ER 5 BUT 0.75 MXC

## VAM

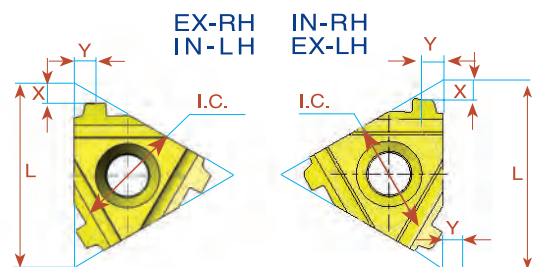
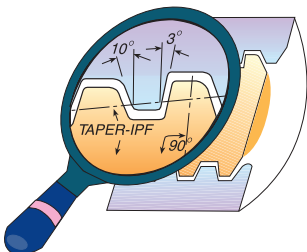

Pitch TPI	L	I.C. in	Taper IPF	<b>EXTERNAL</b>	X	Y	<b>INTERNAL</b>	X	Y	Connection No. or Size
				Ordering Code Right Hand			Ordering Code Right Hand			
8	16	3/8	0.75	<b>16 ER 8 VAM</b>	1.7	1.8	<b>16 IR 8 VAM</b>	1.7	1.8	2 3/8" - 2 7/8"
6	22	1/2	0.75	<b>22 ER 6 VAM</b>	2.4	2.4	<b>22 IR 6 VAM</b>	2.5	2.5	3 1/2" - 4 1/2"
5	22	1/2	0.75	<b>22 ER 5 VAM</b>	2.4	2.7	<b>22 IR 5 VAM</b>	2.4	2.5	5" - 13 3/8"

Order example: 16 ER 8 VAM BMA

For Carbide Grade and Cutting Speed see page 60-61

# Thread Turning Toolholders and Kits



Contents:	Page:	Contents:	Page:
Product Identification	38	Gang Toolholders	44
External Toolholders	39	<b>Quick Change</b>	45-46
External Toolholders with Top Clamp	40	External Toolholders	45
Vertical Toolholders	40	Internal Toolholders	46
Slim Throat Toolholders	40	Special Thread Turning Application	47
Internal Toolholders	41	Anvils and Anvil Kits	48-49
Internal Toolholders with Coolant Bore	42	Standard Kits	50
Internal Toolholders with Top Clamp	42	Miniature & Ultra-miniature Kits	50
Toolholders with 3.5° Helix Angle	42	Inserts' Kits	51
Carbide Shank Boring Bars	43	Threading & Boring Combination Kit	52
Drophead Toolholders	43		
Vertical Toolholders	44		

## Product Identification

### Threading Toolholders Ordering Codes

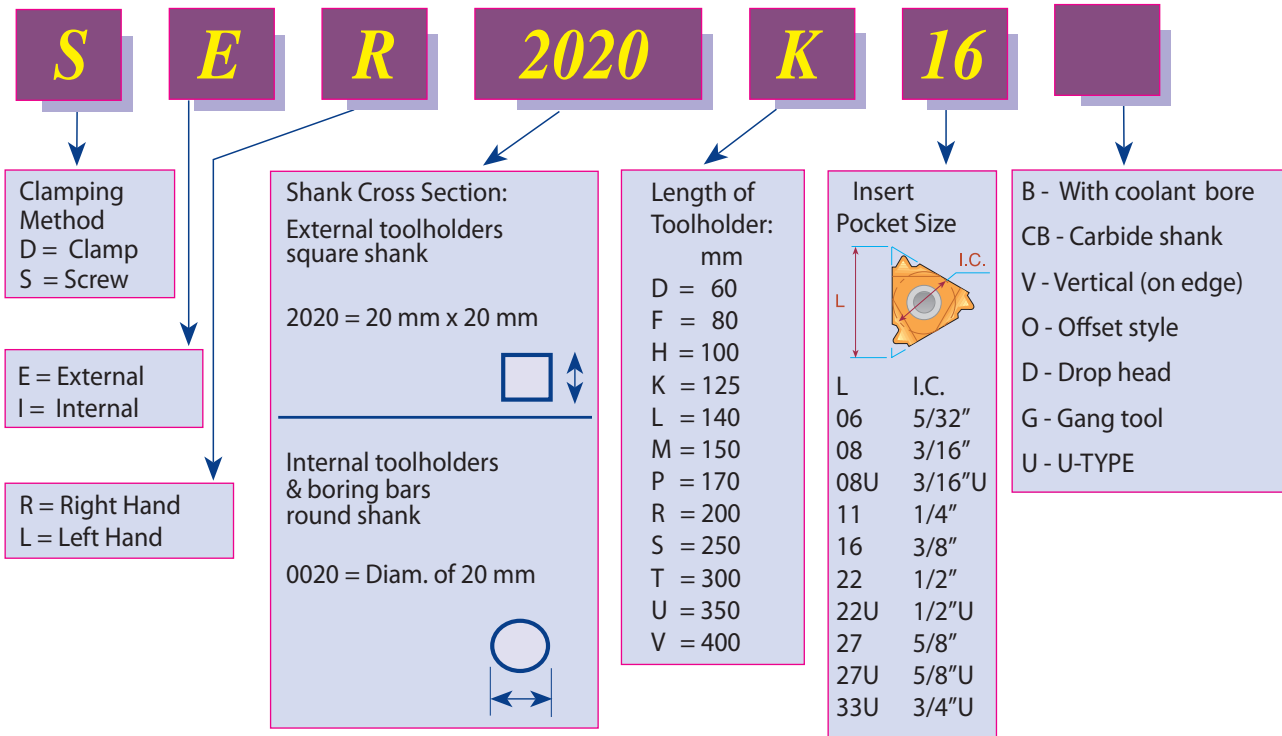

## External Toolholders

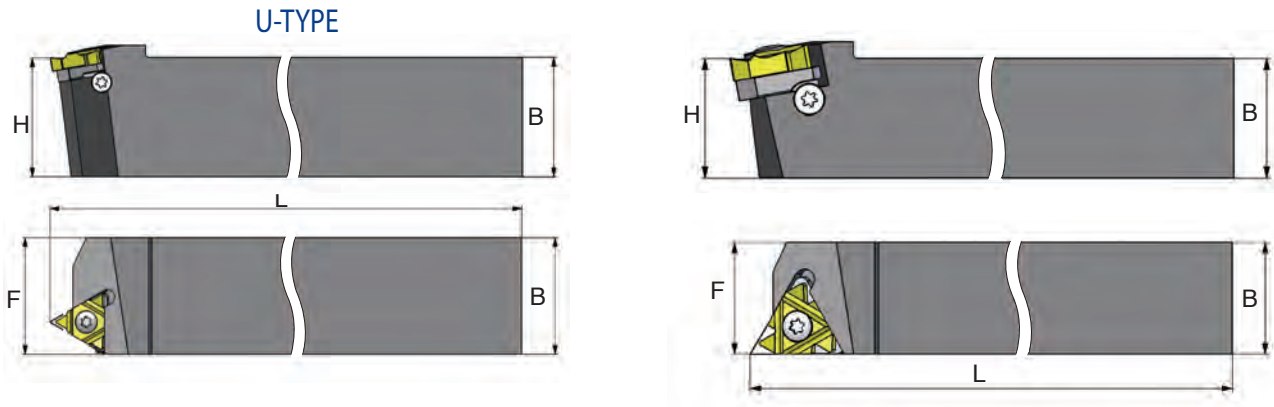

Ordering Code Right Hand		B=H	L	F	Insert Screw	Anvil Screw	Torx Key	RH Anvil	LH Anvil
*SER 8 8 H11	11	8	100	11	S11	-	K11	-	-
*SER 10 10 H11	11	10	100	11	S11	-	K11	-	-
*SER 10 10 M11	11	10	150	11	S11	-	K11	-	-
*SER 12 12 K11	11	12	125	12	S11	-	K11	-	-
*SER 12 12 M11	11	12	150	12	S11	-	K11	-	-
SER 12 12 F16	16	12	80	16	S16	A16	K16	AE16	AI16
SER 16 16 H16	16	16	100	16	S16	A16	K16	AE16	AI16
SER 20 20 K16	16	20	125	20	S16	A16	K16	AE16	AI16
SER 25 25 M16	16	25	150	25	S16	A16	K16	AE16	AI16
SER 32 32 P16	16	32	170	32	S16	A16	K16	AE16	AI16
SER 25 25 M22	22	25	150	25	S22	A22	K22	AE22	AI22
SER 32 32 P22	22	32	170	32	S22	A22	K22	AE22	AI22
SER 40 40 R22	22	40	200	40	S22	A22	K22	AE22	AI22
SER 25 25 M22U	22U	25	150	28	S22	A22	K22	AE22U	AI22U
SER 32 32 P22U	22U	32	170	32	S22	A22	K22	AE22U	AI22U
SER 40 40 R22U	22U	40	200	40	S22	A22	K22	AE22U	AI22U
SER 25 25 M27	27	25	150	32	S27	A27	K27	AE27	AI27
SER 32 32 P27	27	32	170	32	S27	A27	K27	AE27	AI27
SER 40 40 R27	27	40	200	40	S27	A27	K27	AE27	AI27
SER 25 25 M27U	27U	25	150	32	S27	A27	K27	AE27U	AI27U
SER 32 32 P27U	27U	32	170	32	S27	A27	K27	AE27U	AI27U
SER 40 40 R27U	27U	40	200	40	S27	A27	K27	AE27U	AI27U
*SER 25 25 M33U	33U	25	150	32	S33	-	K33	-	-
*SER 32 32 P33U	33U	32	170	32	S33	-	K33	-	-

\*Toolholders with no anvil

For **LEFT HAND** toolholders specify **SEL** instead of **SER**

Toolholders are made with a **1.5° Helix Angle**. For other Helix Angles please see helix angle chart (page 65) in the technical section of this catalog.

## External toolholders with top clamp

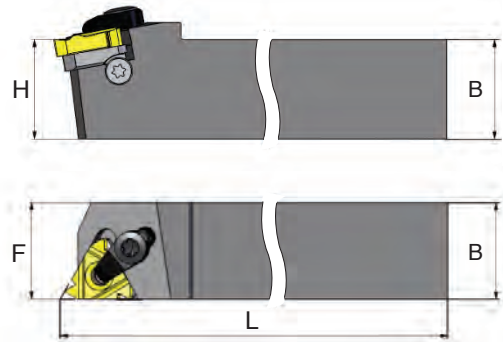

Ordering Code Right Hand	 L	B=H	L	F	Insert Screw	Clamp	Anvil Screw	Torx Key	RH Anvil	LH Anvil
<b>DER 2020 K16</b>	16	20	125	20	S16	C16	A16S	K16	AE16	AI16
<b>DER 2525 M16</b>	16	25	150	25	S16	C16	A16S	K16	AE16	AI16
<b>*DER 2525 M22</b>	22	25	150	25	S22	C22	A22	K22	AE22	AI22

For **LEFT HAND** toolholders specify **DEL** instead of **DER**

Toolholders are made with a **1.5° Helix Angle**. For other Helix Angles please see helix angle chart in the technical section of this catalog.

Two clamping methods can be used: screw or top clamp.

\*Use K21 torx key for C22 clamp

## Vertical toolholders

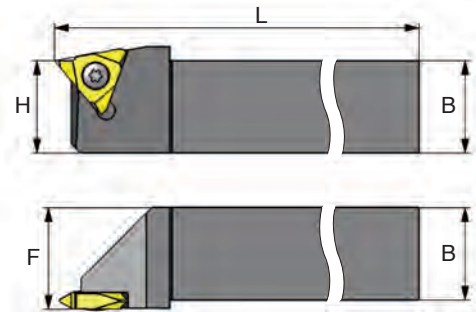

Ordering Code Right Hand		B=H	L	F	Insert Screw	Torx Key
<b>SER 2020 K16V</b>	16	20	125	22	S16S	K16
<b>SER 2525 M16V</b>	16	25	150	27	S16S	K16
<b>SER 2525 M22V</b>	22	25	150	27.5	S22S	K22
<b>SER 3232 P27V-T10</b>	27	32	170	36	S27	K27

## Slim Throat toolholders

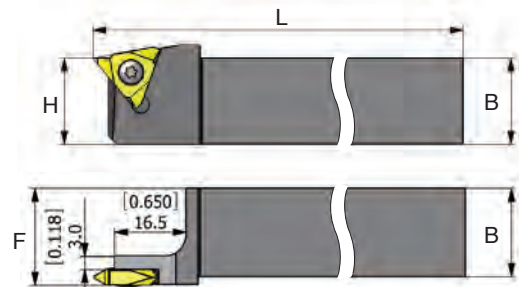

Ordering Code Right Hand		B=H	L	F	Insert Screw	Torx Key
<b>SER 1616 H16VS</b>	16	16	100	18	S16S	K16
<b>SER 2020 K16VS</b>	16	20	125	22	S16S	K16
<b>SER 2525 M16VS</b>	16	25	150	27	S16S	K16

## Internal Toolholders

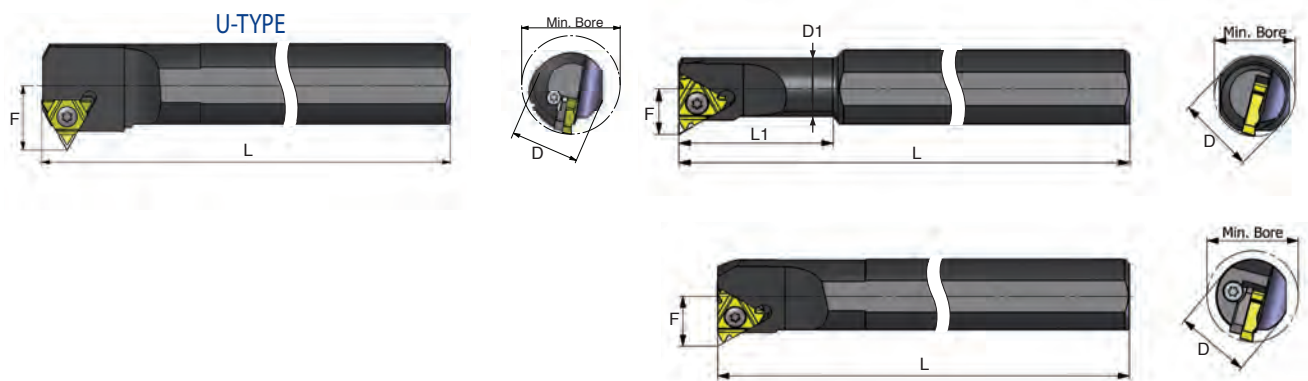

Ordering Code Right Hand		D	D1	Min Bore Diam.	L	L1	F	Insert Screw	Anvil Screw	Torx Key	RH Anvil	LH Anvil
*SIR 0005 H06	6	12	5.1	6.0	100	12	4.3	S06	-	K06	-	-
*SIR 0007 K08	8	16	6.6	7.8	125	18	5.3	S08	-	K08	-	-
*SIR 0008 K08U	8U	16	7.3	9.0	125	21	6.6	S08	-	K08	-	-
*SIR 0010 H11	11	10	10	12	100	-	7.4	S11	-	K11	-	-
*SIR 0010 K11	11	16	10	12	125	25	7.4	S11	-	K11	-	-
*SIR 0013 L11	11	16	13	15	140	32	8.9	S11	-	K11	-	-
*SIR 0013 M16	16	16	13	16	150	32	10.2	S16S	-	K16	-	-
*SIR 0016 P16	16	20	16	19	170	40	11.7	S16S	-	K16	-	-
SIR 0020 P16	16	20	20	24	170	-	13.7	S16	A16	K16	AI16	AE16
SIR 0025 R16	16	25	25	29	200	-	16.2	S16	A16	K16	AI16	AE16
SIR 0032 S16	16	32	32	36	250	-	19.7	S16	A16	K16	AI16	AE16
SIR 0040 T16	16	40	40	44	300	-	23.7	S16	A16	K16	AI16	AE16
*SIR 0020 P22	22	20	20	24	170	-	15.6	S22S	-	K22	-	-
SIR 0025 R22	22	25	25	29	200	-	18.1	S22	A22	K22	AI22	AE22
SIR 0032 S22	22	32	32	38	250	-	21.6	S22	A22	K22	AI22	AE22
SIR 0040 T22	22	40	40	46	300	-	25.6	S22	A22	K22	AI22	AE22
SIR 0050 U22	22	50	50	56	350	-	30.6	S22	A22	K22	AI22	AE22
SIR 0032 S22U	22U	32	32	38	250	-	24.4	S22	A22	K22	AI22U	AE22U
SIR 0040 T22U	22U	40	40	46	300	-	28.1	S22	A22	K22	AI22U	AE22U
SIR 0032 S27	27	32	32	40	250	-	22.6	S27	A27	K27	AI27	AE27
SIR 0040 T27	27	40	40	48	300	-	26.6	S27	A27	K27	AI27	AE27
SIR 0050 U27	27	50	50	58	350	-	31.6	S27	A27	K27	AI27	AE27
SIR 0060 V27	27	60	60	68	400	-	36.6	S27	A27	K27	AI27	AE27
SIR 0032 S27U	27U	32	32	40	250	-	25.8	S27	A27	K27	AI27U	AE27U
SIR 0040 T27U	27U	40	40	48	300	-	29.4	S27	A27	K27	AI27U	AE27U
SIR 0050 U27U	27U	50	50	58	350	-	34.4	S27	A27	K27	AI27U	AE27U
SIR 0060 V27U	27U	60	60	68	400	-	39.7	S27	A27	K27	AI27U	AE27U
*SIR 0050 U33U	33U	50	50	62	350	-	37.5	S33	-	K33	-	-

\*Toolholders with no anvil

For **LEFT HAND** toolholders specify **SIL** instead of **SIR**

Toolholders are made with a **1.5° Helix Angle**. For other Helix Angles please see helix angle chart (page 65) in the technical section of this catalog.

## Internal toolholders with coolant bore

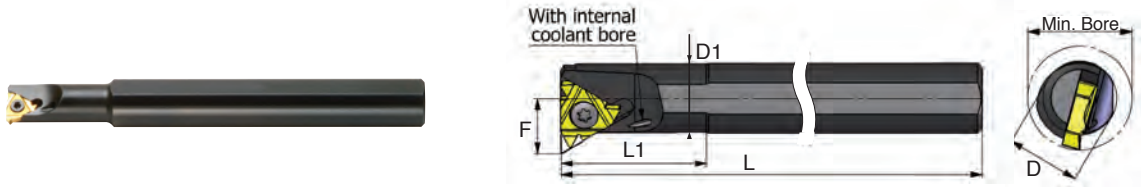

Ordering Code Right Hand	 L	D	D1	Min Bore Diam.	L	L1	F	Insert Screw	Anvil Screw	Torx Key	RH Anvil	LH Anvil
*SIR 0010 K11B	11	16	10	12	125	25	7.4	S11	-	K11	-	-
*SIR 0013 M16B	16	16	13	16	150	32	10.2	S16S	-	K16	-	-
*SIR 0016 P16B	16	20	16	19	170	40	11.7	S16S	-	K16	-	-
SIR 0020 P16B	16	20	20	24	170	-	13.7	S16	A16	K16	AI16	AE16
SIR 0025 R16B	16	25	25	29	200	-	16.2	S16	A16	K16	AI16	AE16
SIR 0025 R22B	22	25	25	29	200	-	18.1	S22	A22	K22	AI22	AE22

\*Toolholders without anvil

For **LEFT HAND** toolholders specify **SIL** instead of **SIR**

Toolholders are made with a **1.5° Helix Angle**. For other Helix Angles please see helix angle chart (page 65) in the technical section of this catalog.

## Internal toolholders with top clamp

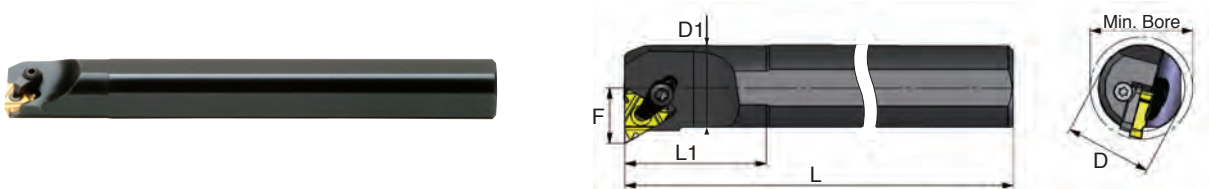

Ordering Code Right Hand	 L	D	D1	Min Bore Diam.	L	L1	F	Insert Screw	Clamp	Anvil Screw	Torx Key	RH Anvil	LH Anvil
DIR 0020 P16	16	20	20	24	170	-	13.7	S16	C16	A16S	K16	AI16	AE16
DIR 0025 R16	16	25	25	29	200	-	16.2	S16	C16	A16S	K16	AI16	AE16
DIR 0032 S16	16	32	32	36	250	-	19.7	S16	C16	A16S	K16	AI16	AE16
* DIR 0025 R22	22	25	25	29	200	-	18.1	S22	C22	A22	K22	AI22	AE22

For **LEFT HAND** toolholders specify **DIL** instead of **DIR**

Two clamping methods can be used: screw or top clamp.

\*Use K21 torx key for C22 clamp

## Toolholders with 3.5° Helix Angle

Ordering Code Right Hand	 L	D	D1	Min Bore Diam. mm	L	L1	F	Insert Screw	Torx Key
SIR 0016 P16B-3.5	16	20	16	19	170	40	13.7	S16S	K16
SIR 0020 P22B-3.5	22	20	20	24	170	-	15.6	S22S	K22

For **LEFT HAND** toolholders specify **SIL** instead of **SIR**



## Carbide Shank Threading Bars With coolant bore

Carbide Shank Threading Bars are used when chatter and deflection are expected due to long overhang in deep small bores.

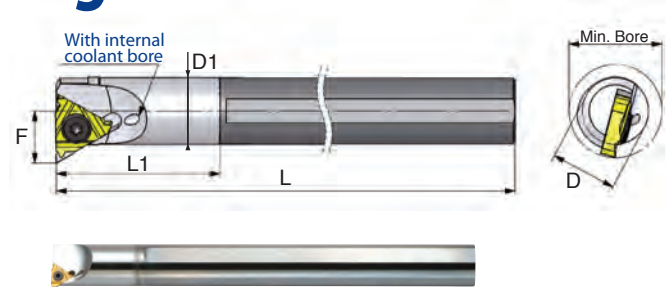

Ordering Code Right Hand		D	D1	Min Bore Diam.	L	L1	F	Insert Screw	Anvil Screw	Torx Key	RH Anvil	LH Anvil
SIR 0005 H06CB	6	6	5.1	6.0	100	26	4.3	S06	-	K06	-	-
SIR 0007 K08CB	8	8	6.6	7.8	125	31	5.3	S08	-	K08	-	-
SIR 0008K08UCB	8U	8	7.3	90	125	35	6.6	S08	-	K08	-	-
SIR 0010 M11CB	11	10	10	12	150	-	7.4	S11	-	K11	-	-
SIR 0012 P11CB	11	12	12	15	170	-	8.4	S11	-	K11	-	-
SIR 0016 R16CB	16	16	16	19	200	-	11.7	S16S	-	K16	-	-
*SIR 0020 S16CB	16	20	20	24	250	-	13.7	S16	A16	K16	AI16	AE16
*SIR 0025 S16CB	16	25	25	29	250	-	16.2	S16	A16	K16	AI16	AE16
SIR 0020 S22CB	22	20	20	24.5	250	-	15.6	S22	-	K22	-	-

\*Carbide shank Threading bars with anvil  
For **LEFT HAND** toolholders specify **SIL** instead of **SIR**

## Drophead Toolholders

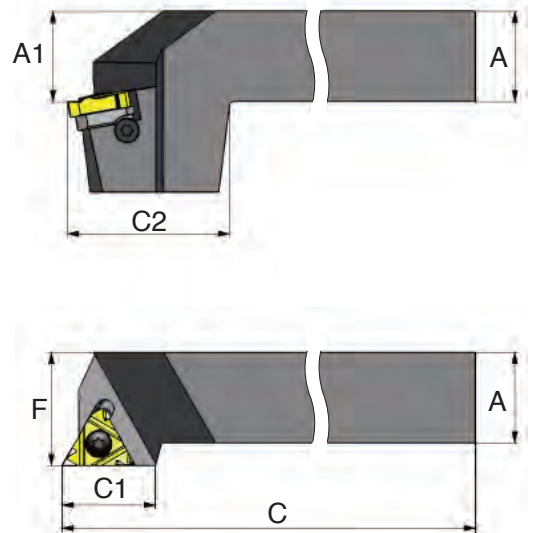

Ordering Code Right Hand		A	A1	C	C1	F	C2	Insert Screw	Anvil Screw	Torx Key	RH Anvil	LH Anvil
SER 2020 K16D	16	20	20	125	21.0	25	38	S16	A16	K16	AE16	AI16
SER 2525 M16D	16	25	25	150	21.0	32	38	S16	A16	K16	AE16	AI16
SER 2525 M22D	22	25	25	150	21.0	32	38	S22	A22	K22	AE22	AI22

## Vertical Toolholders

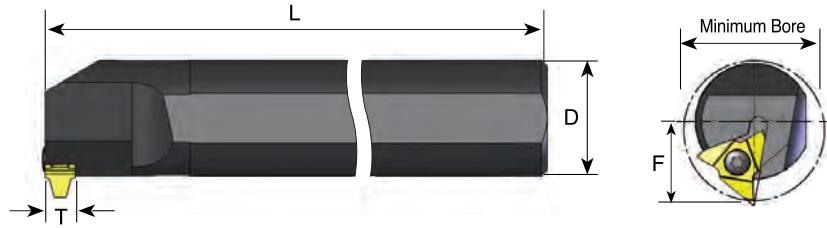

Ordering Code Right Hand	 L	D	* Min Bore Diam.	L	F	Insert Screw	Torx Key
<b>SIR 0040T27V-T10</b>	27	40	48	300	29	S27	K27
<b>SIR 0050U27V-T10</b>	27	50	58	350	34	S27	K27

For **LEFT HAND** toolholders specify **SIL** instead of **SIR**

\* To be compare with given minimum bore profile.

## Gang Toolholders

Gang Toolholders are External Holders, used in small automatic machines with a gang tool post.

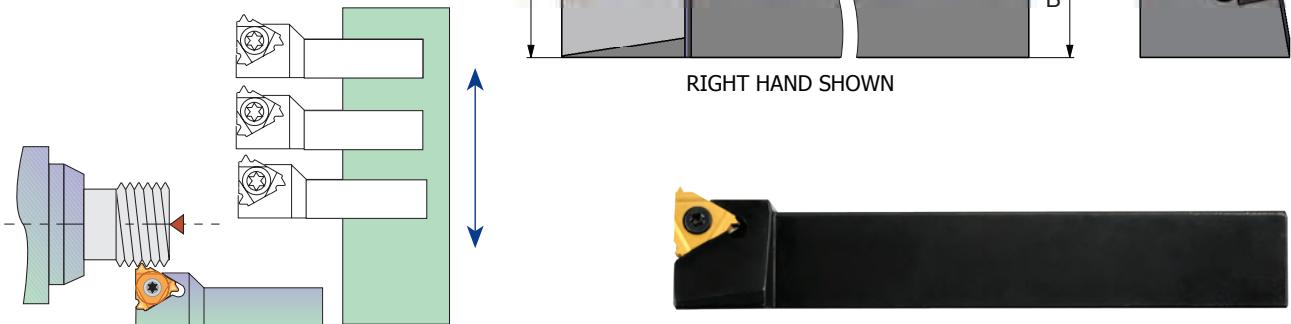

Ordering Code Right Hand	 L	B=H	L	F	Insert Screw	Anvil Screw	Torx Key	RH Anvil	LH Anvil
<b>*SER 8 8 H11G</b>	11	8	100	12.0	S11	-	K11	-	-
<b>*SER 10 10 H11G</b>	11	10	100	14.0	S11	-	K11	-	-
<b>SER 16 16 K16G</b>	16	16	125	21.7	S16	A16	K16	AE16	AI16
<b>SER 20 20 K16G</b>	16	20	125	26.2	S16	A16	K16	AE16	AI16

\*Toolholders with no anvil

For **LEFT HAND** toolholders specify **SEL** instead of **SER**

## Quick Change Polygon Threading Toolholders

- Polygon shank
- ISO standard (26623) compliant for toolholding systems
- Polygon taper ensures automatic radial centering and even pressure around the coupling
- Enable quick tool changes ISO standard coupling system with a 1.4 degree tapered polygon shank design
- Interchangeable with leading manufacturers

## External Toolholders

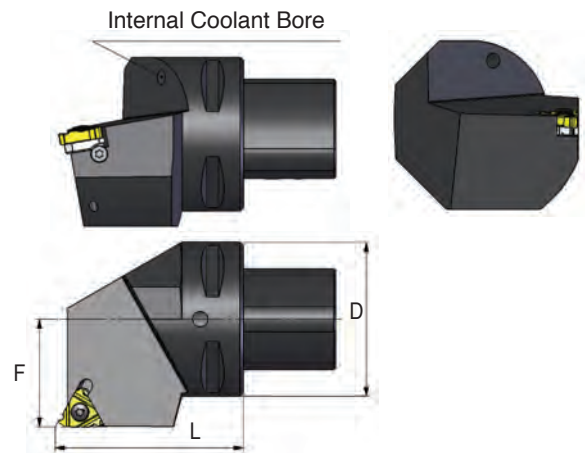

Equivalent to...	Ordering Code		D	F	L	Insert Screw	Anvil Screw	Torx key	RH Anvil	LH Anvil
C4	<b>P40-SER 27050-16</b>	16	40	27	50	S16	A16	K16	AE16	AI16
C5	<b>P50-SER 35060-16</b>	16	50	35	60	S16	A16	K16	AE16	AI16
C6	<b>P63-SER 45065-16</b>	16	63	45	65	S16	A16	K16	AE16	AI16
C4	<b>P40-SER 27050-22</b>	22	40	27	50	S22	A22	K22	AE22	AI22
C5	<b>P50-SER 35060-22</b>	22	50	35	60	S22	A22	K22	AE22	AI22
C6	<b>P63-SER 45065-22</b>	22	63	45	65	S22	A22	K22	AE22	AI22
C8	<b>P80-SER 55080-22</b>	22	80	55	80	S22	A22	K22	AE22	AI22

For **LEFT HAND** toolholders specify **SEL** instead of **SER**

## Internal Toolholders

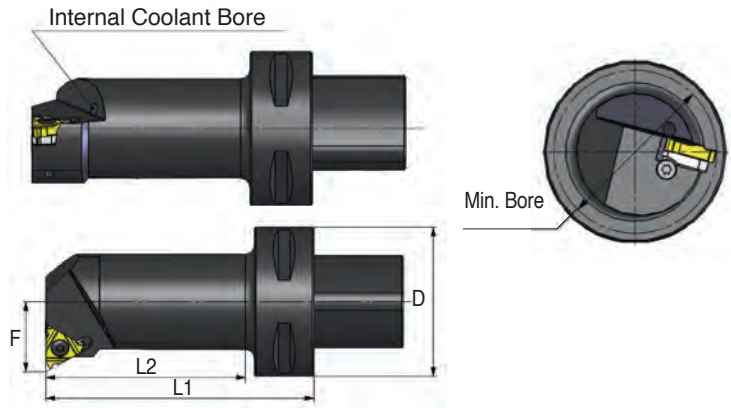

Equivalent to...	Ordering Code		D	F	Min. Bore Dia.	L1	L2	Insert Screw	Anvil Screw	Torx key	RH Anvil	LH Anvil
C4	* P40-SIR 12060-16	16	40	11.7	20	60	37	S16	-	K16	-	-
	P40-SIR 14060-16	16	40	13.5	25	60	38	S16	A16	K16	AI16	AE16
	P40-SIR 17070-16	16	40	16.0	29	70	48	S16	A16	K16	AI16	AE16
	P40-SIR 22090-16	16	40	19.5	36	90	69	S16	A16	K16	AI16	AE16
	P40-SIR 27080-16	16	40	23.5	44	80	60	S16	A16	K16	AI16	AE16
C5	* P50-SIR 12060-16	16	50	11.7	20	60	35	S16	-	K16	-	-
	P50-SIR 14060-16	16	50	13.5	25	60	36	S16	A16	K16	AI16	AE16
	P50-SIR 17070-16	16	50	16.0	29	70	47	S16	A16	K16	AI16	AE16
	P50-SIR 22090-16	16	50	19.5	36	90	68	S16	A16	K16	AI16	AE16
	P50-SIR 27105-16	16	50	23.5	44	105	84	S16	A16	K16	AI16	AE16
C6	P63-SIR 14070-16	16	63	13.5	25	70	42	S16	A16	K16	AI16	AE16
	P63-SIR 17075-16	16	63	16.0	29	75	48	S16	A16	K16	AI16	AE16
	P63-SIR 22090-16	16	63	19.5	36	90	64	S16	A16	K16	AI16	AE16
	P63-SIR 27105-16	16	63	23.5	44	105	80	S16	A16	K16	AI16	AE16
C4	* P40-SIR 15065-22	22	40	15.4	25	65	42	S22	-	K22	-	-
	P40-SIR 19070-22	22	40	17.9	29	70	48	S22	A22	K22	AI22	AE22
	P40-SIR 22090-22	22	40	21.4	38	90	69	S22	A22	K22	AI22	AE22
	P40-SIR 27080-22	22	40	25.4	46	80	60	S22	A22	K22	AI22	AE22
C5	* P50-SIR 15065-22	22	50	15.4	25	65	41	S22	-	K22	-	-
	P50-SIR 19070-22	22	50	17.9	29	70	47	S22	A22	K22	AI22	AE22
	P50-SIR 22090-22	22	50	21.4	38	90	68	S22	A22	K22	AI22	AE22
	P50-SIR 27105-22	22	50	25.4	46	105	84	S22	A22	K22	AI22	AE22
C6	P63-SIR 19075-22	22	63	17.9	29	75	48	S22	A22	K22	AI22	AE22
	P63-SIR 22090-22	22	63	21.4	38	90	64	S22	A22	K22	AI22	AE22
	P63-SIR 27105-22	22	63	25.4	46	105	80	S22	A22	K22	AI22	AE22

For **LEFT HAND** toolholders specify **SIL** instead of **SIR**

\* Holders without anvil

## Special Thread Turning Applications

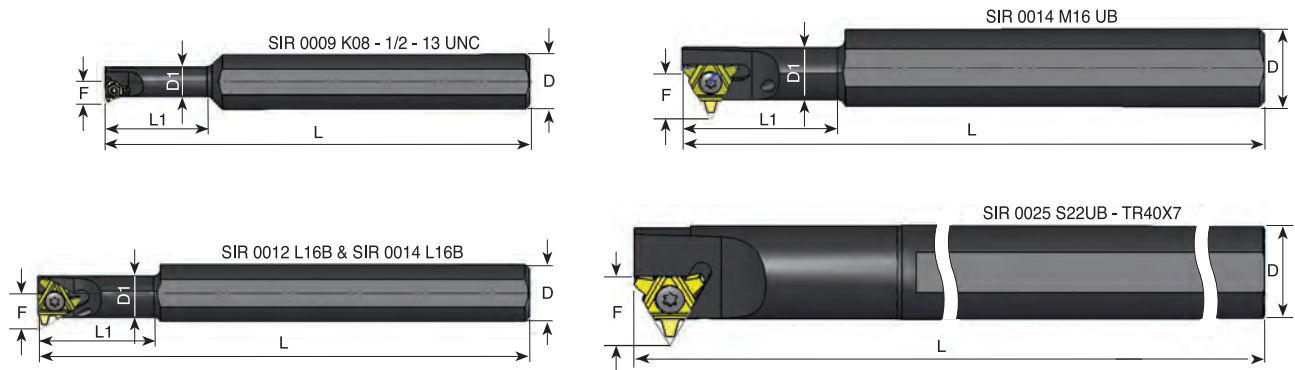

Ordering Code Right Hand		D	D1	L	L1	F	Thread	Insert Screw	Torx Key
<b>*SIR 0009 K08</b>	8	16	8.7	125	30	6.5	<b>1/2 - 13UNC</b>	S08	K08
<b>SIR 0012 L16B</b>	16	20	11.5	140	33	10.5	<b>TR18x4</b>	S16S	K16
<b>SIR 0014 L16B</b>	16	20	12.5	140	36	21.1	<b>TR20x4</b>	S16S	K16
<b>SIR 0014 M16UB</b>	16	20	13.5	150	40	13.2	<b>TR22x5</b>	S16S	K16
<b>SIR 0025 S22UB</b>	22	25	-	250	-	19.5	<b>TR40x7</b>	S22S	K22

For LH holders call Carmex  
\* Only right hand available

## Large Profile Range

- Pitch Range: 14mm up to 24 mm.
- Tools and inserts are offered as specials (non catalog), because each holder has to be modified to fit the profile shape.
- Rigid Clamping

*External*

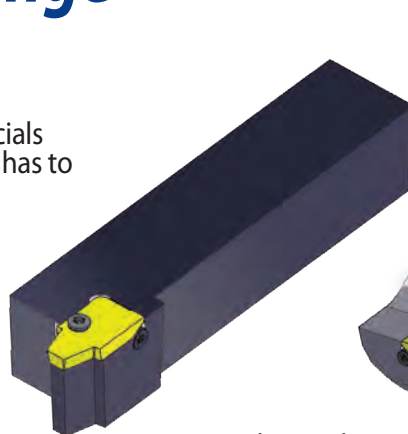

*Internal*



- Tailor made profiles according to customer's request

Available Profile	<b>Round (DIN 20400)</b>	<b>Trapez (DIN 103)</b>	<b>Acme, Stub Acme</b>	<b>American Buttress</b>
Pitch	16 mm	14-24 mm	1.0 - 1.5 TPI	1.5 - 2.0 TPI

## Thread Helix Angle

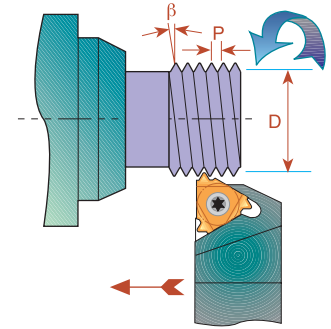
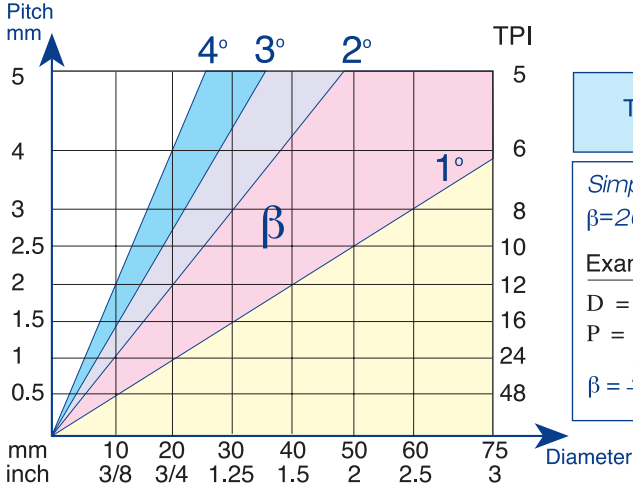

## Standard and Slanted Anvils

CARMEX Toolholder Pockets have a built in 1.5° helix angle. This angle may be adjusted to better match the thread helix angle by simply changing the anvil.

Negative helix is usually used when threading RH thread with LH Holder or LH thread with RH Holder.

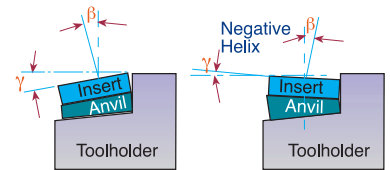

L	IC	Pocket Angle	4.5°	3.5°	2.5°	1.5° Standard	0.5°	-0.5°	-1.5°
16	3/8	EX-RH OR IN-LH	AE16+4.5	AE16+3.5	AE16+2.5	<b>AE16</b>	AE16+0.5	AE16-0.5	AE16-1.5
16	3/8	EX-LH OR IN-RH	AI 16+4.5	AI 16+3.5	AI 16+2.5	<b>AI 16</b>	AI 16+0.5	AI 16-0.5	AI 16-1.5
22	1/2	EX-RH OR IN-LH	AE22+4.5	AE22+3.5	AE22+2.5	<b>AE22</b>	AE22+0.5	AE22-0.5	AE22-1.5
22	1/2	EX-LH OR IN-RH	AI 22+4.5	AI 22+3.5	AI 22+2.5	<b>AI 22</b>	AI 22+0.5	AI 22-0.5	AI 22-1.5
22U	1/2U	EX-RH OR IN-LH	AE22U+4.5	AE22U+3.5	AE22U+2.5	<b>AE22U</b>	AE22U+0.5	AE22U-0.5	AE22U-1.5
22U	1/2U	EX-LH OR IN-RH	AI 22U+4.5	AI 22U+3.5	AI 22U+2.5	<b>AI 22U</b>	AI 22U+0.5	AI 22U-0.5	AI 22U-1.5
27	5/8	EX-RH OR IN-LH	AE27+4.5	AE27+3.5	AE27+2.5	<b>AE27</b>	AE27+0.5	AE27-0.5	AE27-1.5
27	5/8	EX-LH OR IN-RH	AI 27+4.5	AI 27+3.5	AI 27+2.5	<b>AI 27</b>	AI 27+0.5	AI 27-0.5	AI 27-1.5
27U	5/8U	EX-RH OR IN-LH	AE27U+4.5	AE27U+3.5	AE27U+2.5	<b>AE27U</b>	AE27U+0.5	AE27U-0.5	AE27U-1.5
27U	5/8U	EX-LH OR IN-RH	AI 27U+4.5	AI 27U+3.5	AI 27U+2.5	<b>AI 27U</b>	AI 27U+0.5	AI 27U-0.5	AI 27U-1.5

## Anvil Kits

5 AE and 5 AI anvils with various helix angles



AE (FOR EX.RH. & IN.LH.)



AI (FOR IN.RH. & EX.LH.)

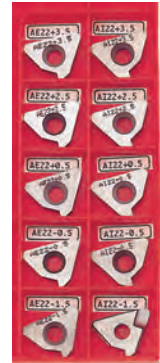

Ordering Code	Contents				
<b>KA16</b>	AE16+4.5 AI 16+4.5	AE16+3.5 AI 16+3.5	AE16+2.5 AI 16+2.5	AE16+0.5 AI 16+0.5	AE16-1.5 AI 16-1.5
<b>KA22</b>	AE22+4.5 AI 22+4.5	AE22+3.5 AI 22+3.5	AE22+2.5 AI 22+2.5	AE22+0.5 AI 22+0.5	AE22-1.5 AI 22-1.5
<b>KA22U</b>	AE22U+4.5 AI 22U+4.5	AE22U+3.5 AI 22U+3.5	AE22U+2.5 AI 22U+2.5	AE22U+0.5 AI 22U+0.5	AE22U-1.5 AI 22U-1.5
<b>KA27</b>	AE27+4.5 AI 27+4.5		AE27+2.5 AI 27+2.5		AE27-1.5 AI 27-1.5
<b>KA27U</b>	AE27U+4.5 AI 27U+4.5		AE27U+2.5 AI 27U+2.5		AE27U-1.5 AI 27U-1.5

## Standard Kits

Threading Kits are a versatile solution for users that cut a variety of thread types in limited quantity and do not want to sacrifice thread quality.

### External ISO Kit Ordering Code:KEG

#### INSERTS

- 16 ER A60 P25C
- 16 ER G60 P25C
- 16 ER 0.75 ISO P25C
- 16 ER 1.0 ISO P25C
- 16 ER 1.25 ISO P25C
- 16 ER 1.5 ISO P25C
- 16 ER 1.75 ISO P25C
- 16 ER 2.0 ISO P25C
- 16 ER 2.5 ISO P25C
- 16 ER 3.0 ISO P25C

#### TOOLHOLDERS

- SER 2020 K16
- KEY
- K16
- SCREW
- S16

### Internal ISO Kit Ordering Code:KIG

#### INSERTS

- 16 IR A60 P25C
- 16 IR G60 P25C
- 16 IR 0.75 ISO P25C
- 16 IR 1.0 ISO P25C
- 16 IR 1.25 ISO P25C
- 16 IR 1.5 ISO P25C
- 16 IR 1.75 ISO P25C
- 16 IR 2.0 ISO P25C
- 16 IR 2.5 ISO P25C
- 16 IR 3.0 ISO P25C

#### TOOLHOLDERS

- SIR 0020 K16
- KEY
- K16
- SCREW
- S16



If a larger toolholders with a 25 mm shank is required, add to the kit 25. For example: KIG - 25

## Miniature & Ultra-Miniature Kits



Ordering Code	Type	No. of Inserts	Inserts	Contents Boring Bar	Key
<b>KU60M - BXC</b>	ULTRA	10	06 IR A60 BXC	SIR 0005 H06	K6
<b>KM60M - BXC</b>	MINI	10	08 IR A60 BXC	SIR 0007 K08	K8



## Inserts' Kits

### Type B Kits

Type B threading inserts.  
 A combination of ground profile and sintered chip-breaker threading inserts.  
 BMA Grade: Sub-Micron carbide grade with TiAlN multi-layer Coating.

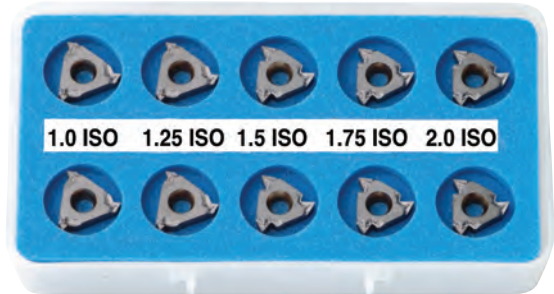

#### EXTERNAL ISO KIT KEMB - BMA

- 16 ER B 1.0 ISO BMA-2 Pcs
- 16 ER B 1.25 ISO BMA-2 Pcs
- 16 ER B 1.5 ISO BMA-2 Pcs
- 16 ER B 1.75 ISO BMA-2 Pcs
- 16 ER B 2.0 ISO BMA-2 Pcs



EX-RH

#### INTERNAL ISO KIT KIMB - BMA

- 16 IR B 1.0 ISO BMA-2 Pcs
- 16 IR B 1.25 ISO BMA-2 Pcs
- 16 IR B 1.5 ISO BMA-2 Pcs
- 16 IR B 1.75 ISO BMA-2 Pcs
- 16 IR B 2.0 ISO BMA-2 Pcs



IN-RH

### Standard Inserts' Kits

#### EXTERNAL ISO KIT

- 16 ER 1.0 ISO-2 Pcs
- 16 ER 1.25 ISO-2 Pcs
- 16 ER 1.5 ISO-2 Pcs
- 16 ER 1.75 ISO-2 Pcs
- 16 ER 2.0 ISO-2 Pcs

#### INTERNAL ISO KIT

- 16 IR 1.0 ISO-2 Pcs
- 16 IR 1.25 ISO-2 Pcs
- 16 IR 1.5 ISO-2 Pcs
- 16 IR 1.75 ISO-2 Pcs
- 16 IR 2.0 ISO-2 Pcs

Ordering Code: KEM

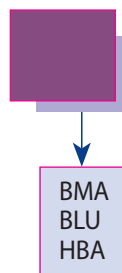

Ordering Code: KIM

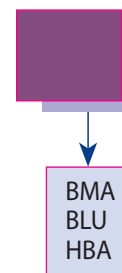

## Threading & Boring Combination Kit

A practical and convenient combination kit for **Ultra Miniature** Threading and Boring. It enables Boring and Threading of mini bores as small as **6 mm diameter (1/4")** with just one deep reaching **CARBIDE** shank ultra mini Boring Bar.



Ordering Code	Contents			
	Threading Insert	Turning Inserts	Boring Bar	Key
<b>KC6TM</b>	06 IR A60 BXC 10Pcs	06 IR TURN BMA 10Pcs	SIR 0005 H06CB	K6

**BMA** - Coated carbide grade for medium to high cutting speeds

**BXC** - Coated carbide grade for low cutting speed - 40 to 90 m/min

**CB** - Carbide shank boring bar with coolant bore

# Double Sided Thread Turning Inserts

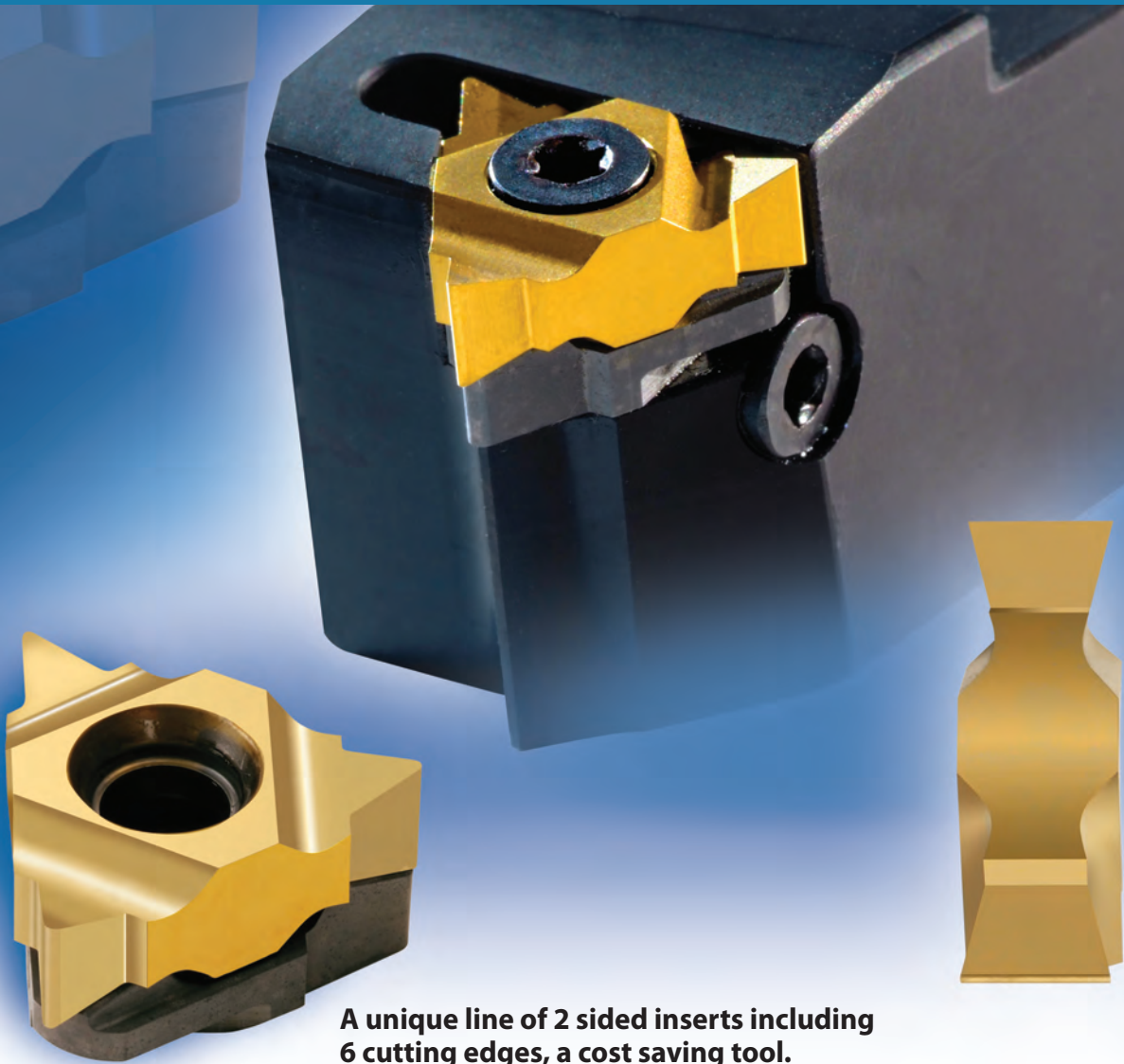

**A unique line of 2 sided inserts including 6 cutting edges, a cost saving tool.**

## Advantages of DSI-Thread Turning Inserts

- Increased productivity thanks to the six cutting edges.
- U-Style inserts for a wide range of full or partial profile standard threads.
- Same insert for right hand or left hand thread.
- Saving on tooling costs.
- Unique anti-vibration anvil designed for clamping the insert and supporting the cutting edge.
- Simple insert's mounting and cutting edge indexing.
- Heavy duty toolholders designed specially for this line.

### Contents:

### Page:

Product Identification	54
Partial Profile 60°	55
Partial Profile 55°	55
ISO	56
UN	56
Whitworth 55°	57
NPT	57
Thread Turning Toolholder - External	58
Thread Turning Toolholder - Internal	58

## Product Identification

### DSI Ordering Code

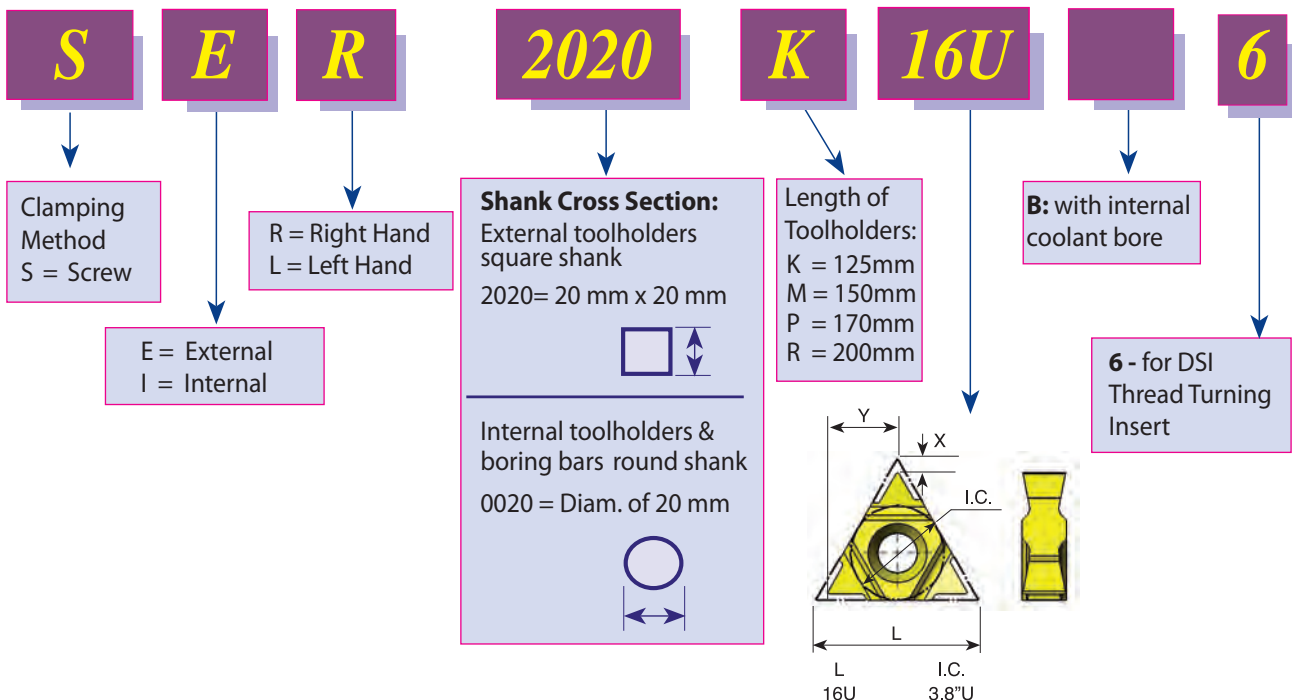
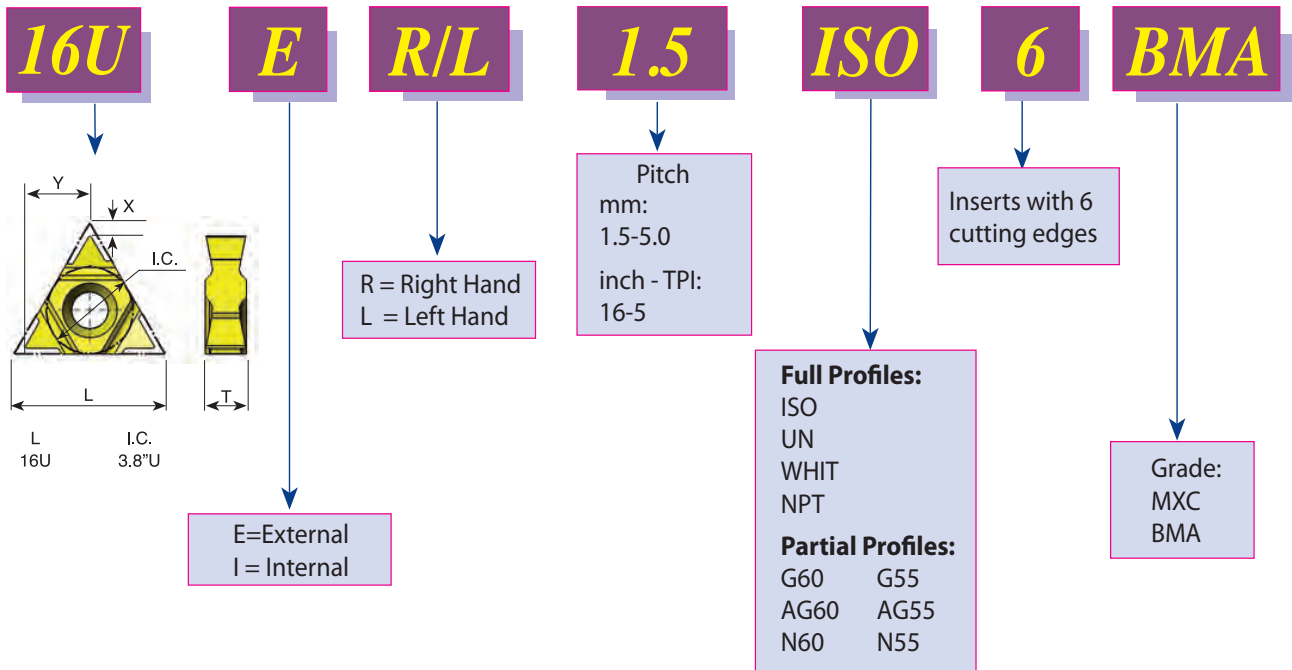

## Partial Profile 60°

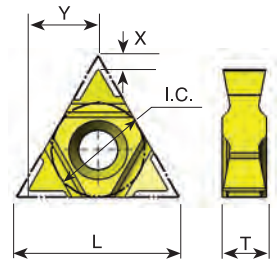

Pitch Range mm	Pitch Range TPI	L	I.C. in	<b>EXTERNAL</b> Ordering Code	<b>INTERNAL</b> Ordering Code	X	Y	T
1.75 - 3.0	14-8	16U	3/8U	<b>16U ER/L G60-6</b>	<b>16U IR/L G60-6</b>	1.4	7.1	4.5
0.5 - 3.0	48-8	16U	3/8U	<b>16U ER/L AG60-6</b>	<b>16U IR/L AG60-6</b>	1.4	7.1	4.5
3.5 - 5.0	7-5	16U	3/8U	<b>16U ER/L N60-6</b>	<b>16U IR/L N60-6</b>	1.2	7.3	4.5

Available grades: BMA or MXC

## Partial Profile 55°

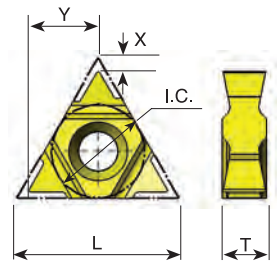

Pitch Range mm	Pitch Range TPI	L	I.C. in	<b>EXTERNAL</b> Ordering Code	<b>INTERNAL</b> Ordering Code	X	Y	T
1.75 - 3.0	14-8	16U	3/8U	<b>16U ER/L G55-6</b>	<b>16U IR/L G55-6</b>	1.4	7.1	4.5
0.5 - 3.0	48-8	16U	3/8U	<b>16U ER/L AG55-6</b>	<b>16U IR/L AG55-6</b>	1.4	7.1	4.5
3.5 - 5.0	7-5	16U	3/8U	<b>16U ER/L N55-6</b>	<b>16U IR/L N55-6</b>	1.2	7.3	4.5

Available grades: BMA or MXC

For Carbide Grade and Cutting Speed see page 60-61

## ISO

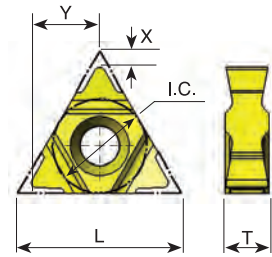

Pitch mm	L	I.C. in	<b>EXTERNAL</b> Ordering Code	<b>INTERNAL</b> Ordering Code	X	Y	T
1.5	16U	3/8U	<b>16U ER/L 1.5 ISO-6</b>	<b>16U IR/L 1.5 ISO-6</b>	1.6	6.9	4.5
1.75	16U	3/8U	<b>16U ER/L 1.75 ISO-6</b>	<b>16U IR/L 1.75 ISO-6</b>	1.6	6.9	4.5
2.0	16U	3/8U	<b>16U ER/L 2.0 ISO-6</b>	<b>16U IR/L 2.0 ISO-6</b>	1.6	6.9	4.5
2.5	16U	3/8U	<b>16U ER/L 2.5 ISO-6</b>	<b>16U IR/L 2.5 ISO-6</b>	1.6	6.9	4.5
3.0	16U	3/8U	<b>16U ER/L 3.0 ISO-6</b>	<b>16U IR/L 3.0 ISO-6</b>	1.6	6.9	4.5
3.5	16U	3/8U	<b>16U ER/L 3.5 ISO-6</b>	<b>16U IR/L 3.5 ISO-6</b>	1.6	6.9	4.5
4.0	16U	3/8U	<b>16U ER/L 4.0 ISO-6</b>	<b>16U IR/L 4.0 ISO-6</b>	1.6	6.9	4.5
4.5	16U	3/8U	<b>16U ER/L 4.5 ISO-6</b>	<b>16U IR/L 4.5 ISO-6</b>	1.6	6.9	4.5
5.0	16U	3/8U	<b>16U ER/L 5.0 ISO-6</b>	<b>16U IR/L 5.0 ISO-6</b>	1.6	6.9	4.5

Available grades: BMA or MXC

## UN - Unified **UNC, UNF, UNEF, UNS**

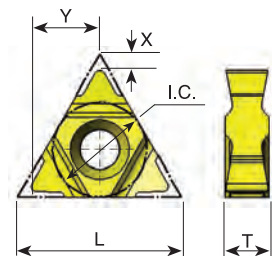

Pitch TPI	L	I.C. in	<b>EXTERNAL</b> Ordering Code	<b>INTERNAL</b> Ordering Code	X	Y	T
16	16U	3/8U	<b>16U ER/L 16 UN-6</b>	<b>16U IR/L 16 UN-6</b>	1.6	6.9	4.5
14	16U	3/8U	<b>16U ER/L 14 UN-6</b>	<b>16U IR/L 14 UN-6</b>	1.6	6.9	4.5
13	16U	3/8U	<b>16U ER/L 13 UN-6</b>	<b>16U IR/L 13 UN-6</b>	1.6	6.9	4.5
12	16U	3/8U	<b>16U ER/L 12 UN-6</b>	<b>16U IR/L 12 UN-6</b>	1.6	6.9	4.5
11.5	16U	3/8U	<b>16U ER/L 11.5 UN-6</b>	<b>16U IR/L 11.5 UN-6</b>	1.6	6.9	4.5
11	16U	3/8U	<b>16U ER/L 11 UN-6</b>	<b>16U IR/L 11 UN-6</b>	1.6	6.9	4.5
10	16U	3/8U	<b>16U ER/L 10 UN-6</b>	<b>16U IR/L 10 UN-6</b>	1.6	6.9	4.5
9	16U	3/8U	<b>16U ER/L 9 UN-6</b>	<b>16U IR/L 9 UN-6</b>	1.6	6.9	4.5
8	16U	3/8U	<b>16U ER/L 8 UN-6</b>	<b>16U IR/L 8 UN-6</b>	1.6	6.9	4.5
7	16U	3/8U	<b>16U ER/L 7 UN-6</b>	<b>16U IR/L 7 UN-6</b>	1.6	6.9	4.5
6	16U	3/8U	<b>16U ER/L 6 UN-6</b>	<b>16U IR/L 6 UN-6</b>	1.6	6.9	4.5
5	16U	3/8U	<b>16U ER/L 5 UN-6</b>	<b>16U IR/L 5 UN-6</b>	1.6	6.9	4.5

Available grades: BMA or MXC

For Carbide Grade and Cutting Speed see page 60-61

## Whitworth 55° BSW, BSF, BSP, BSB

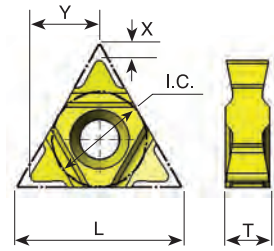

Pitch TPI	L	I.C. in	<b>EXTERNAL</b> Ordering Code	<b>INTERNAL</b> Ordering Code	X	Y	T
16	16U	3/8U	<b>16U ER/L 16 W-6</b>	<b>16U IR/L 16 W-6</b>	1.6	6.9	4.5
14	16U	3/8U	<b>16U ER/L 14 W-6</b>	<b>16U IR/L 14 W-6</b>	1.6	6.9	4.5
12	16U	3/8U	<b>16U ER/L 12 W-6</b>	<b>16U IR/L 12 W-6</b>	1.6	6.9	4.5
11	16U	3/8U	<b>16U ER/L 11 W-6</b>	<b>16U IR/L 11 W-6</b>	1.6	6.9	4.5
10	16U	3/8U	<b>16U ER/L 10 W-6</b>	<b>16U IR/L 10 W-6</b>	1.6	6.9	4.5
9	16U	3/8U	<b>16U ER/L 9 W-6</b>	<b>16U IR/L 9 W-6</b>	1.6	6.9	4.5
8	16U	3/8U	<b>16U ER/L 8 W-6</b>	<b>16U IR/L 8 W-6</b>	1.6	6.9	4.5
7	16U	3/8U	<b>16U ER/L 7 W-6</b>	<b>16U IR/L 7 W-6</b>	1.6	6.9	4.5
6	16U	3/8U	<b>16U ER/L 6 W-6</b>	<b>16U IR/L 6 W-6</b>	1.6	6.9	4.5
5	16U	3/8U	<b>16U ER/L 5 W-6</b>	<b>16U IR/L 5 W-6</b>	1.4	7.2	4.5

Available grades: BMA or MXC

## NPT

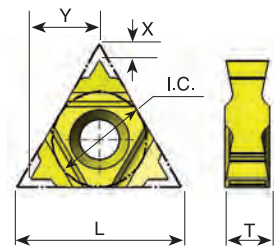

Pitch TPI	L	I.C. in	<b>EXTERNAL</b> Ordering Code	<b>INTERNAL</b> Ordering Code	X	Y	T
14	16U	3/8U	<b>16U ER/L 14 NPT-6</b>	<b>16U IR/L 14 NPT-6</b>	1.6	6.9	4.5
11.5	16U	3/8U	<b>16U ER/L 11.5 NPT-6</b>	<b>16U IR/L 11.5 NPT-6</b>	1.6	6.9	4.5
8	16U	3/8U	<b>16U ER/L 8 NPT-6</b>	<b>16U IR/L 8 NPT-6</b>	1.6	6.9	4.5

Available grades: BMA or MXC

For Carbide Grade and Cutting Speed see page 60-61

## Heavy Duty Thread Turning Toolholders

### External

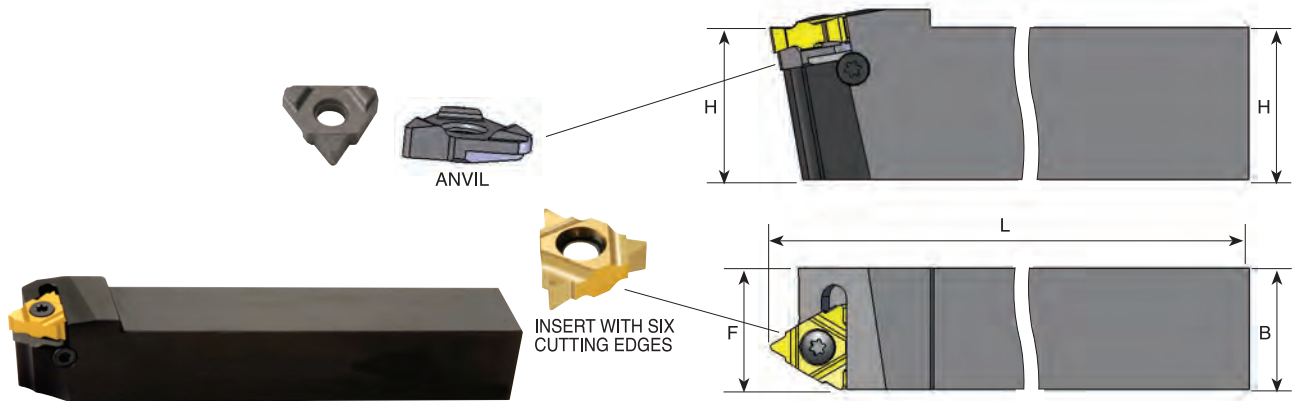

Ordering Code Right Hand	H	B	L	F	Insert Screw	Anvil Screw	Torx Key	RH Anvil	LH Anvil
<b>SER 2020 K16U-6</b>	20	20	125	20	S16	A16	K16	AER 16U-6	AEL 16U-6
<b>SER 2520 M16U-6</b>	25	20	150	20	S16	A16	K16	AER 16U-6	AEL 16U-6

For **LEFT HAND** toolholders specify **SEL** instead of **SER**

### Internal with coolant bore

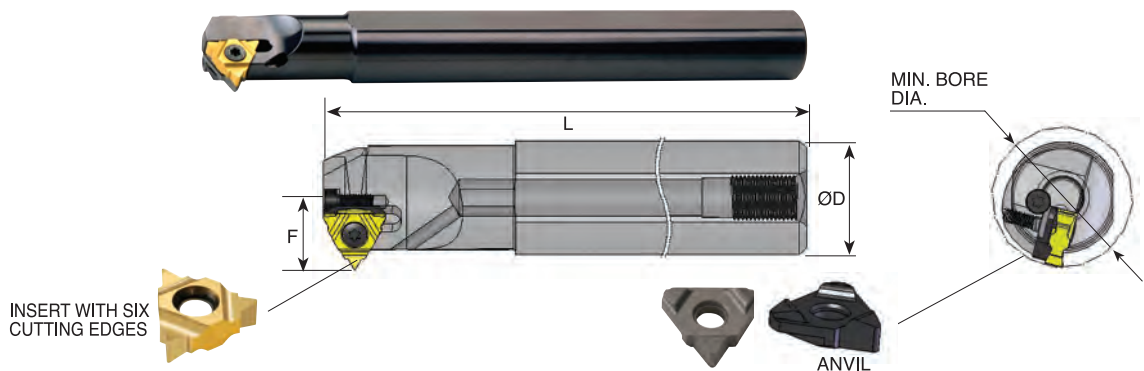

Ordering Code Right Hand	ØD	Min. bore dia.	L	F	Insert Screw	Anvil Screw	Torx Key	RH Anvil	LH Anvil
<b>SIR 0020 P16UB-6</b>	20	24	170	14.9	S16	A16	K16	AIR 16U-6	AIL 16U-6
<b>SIR 0025 R16UB-6</b>	25	29	200	17.4	S16	A16	K16	AIR 16U-6	AIL 16U-6

For **LEFT HAND** toolholders specify **SIL** instead of **SIR**