

YG-1 ИНСТРУМЕНТАЛЬНАЯ ОСНАСТКА

ГИДРАВЛИЧЕСКИЕ ПАТРОНЫ



DIN 69871-SK

С ВОЗМОЖНОСТЬЮ ПРЕДВАРИТЕЛЬНОЙ РАДИАЛЬНОЙ РЕГУЛИРОВКИ ВЫЛЕТА ИНСТРУМЕНТА

DIN 69893/ISO 12164-1-HSK

С ВОЗМОЖНОСТЬЮ ПРЕДВАРИТЕЛЬНОЙ РАДИАЛЬНОЙ РЕГУЛИРОВКИ ВЫЛЕТА ИНСТРУМЕНТА

CBT (BT DUAL CONTACT)

С ВОЗМОЖНОСТЬЮ ПРЕДВАРИТЕЛЬНОЙ РАДИАЛЬНОЙ РЕГУЛИРОВКИ ВЫЛЕТА ИНСТРУМЕНТА

JIS B6339/MAS 403-BT

С ВОЗМОЖНОСТЬЮ ПРЕДВАРИТЕЛЬНОЙ РАДИАЛЬНОЙ РЕГУЛИРОВКИ ВЫЛЕТА ИНСТРУМЕНТА

ГИДРОПАТРОН (ДЛЯ ПРЕСС-ФОРМ)

JIS B6339/MAS 403-BT, DIN 69871-SK, DIN 69893/ISO 12164-1-HSK, DIN 228-MTB

НАБОР ГИДРОПАТРОНОВ

АКСЕССУАРЫ

ЦАНГИ (ПЕРЕХОДНЫЕ ВТУЛКИ) : НК / HS / HF / HR

ТЕХНИЧЕСКАЯ ИНФОРМАЦИЯ ГИДРАВЛИЧЕСКИЙ ПАТРОН



Высокая точность

Биение : ≤ 0.003 мм (Без балансирующего винта)

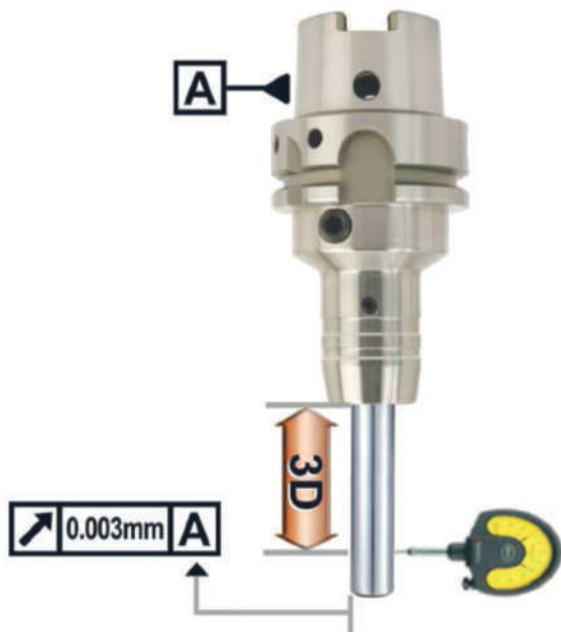

- \Rightarrow Подходит для высокоскоростной точной обработки

Различные варианты применения инструмента за счет использования переходных втулок

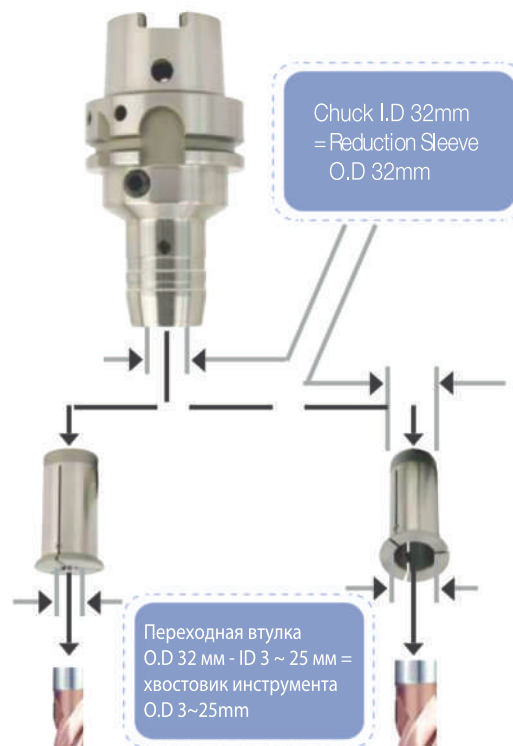

Легкая замена инструмента

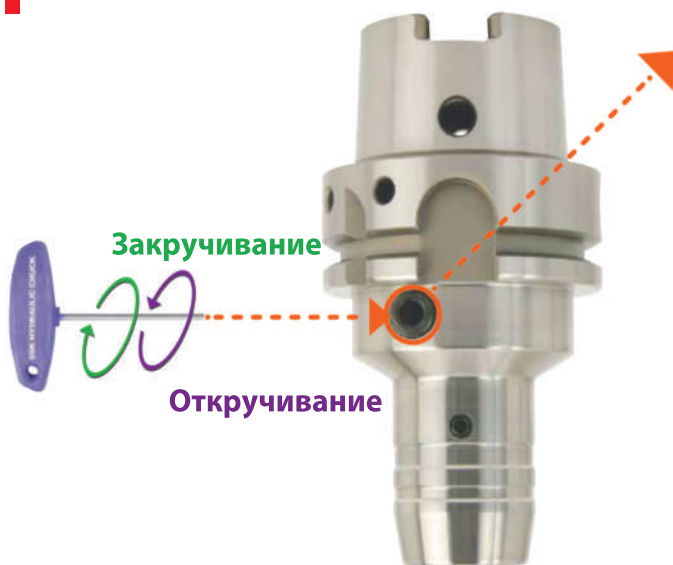

- Легкая установка благодаря Т-образному винту \Rightarrow Сокращение времени на смену инструмента

ЗАЖИМНОЙ ВИНТ

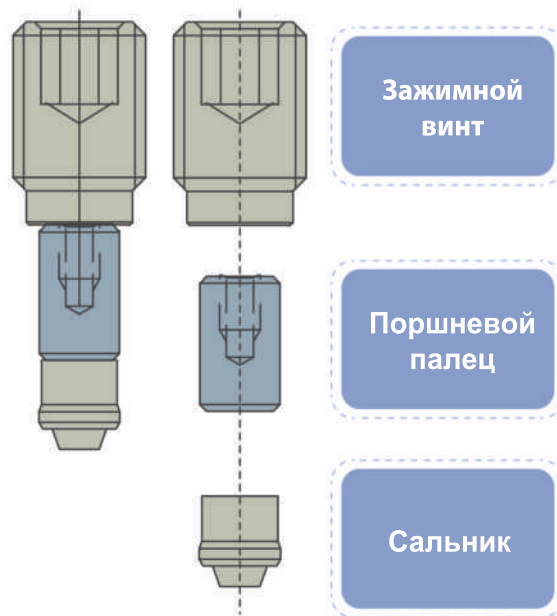

ТЕХНИЧЕСКАЯ ИНФОРМАЦИЯ ГИДРАВЛИЧЕСКИЙ ПАТРОН



Крутящий момент

Гидравлический патрон I.D(mm)	Хвостовик O.D(mm)	Applicable RPM	Минимальная глубина зажима(mm)		Мин. крутящ. Момент (Nm)	
			Slim	Power E Hydro	Slim	Power E Hydro
6	6	40,000	27		16	
8	8	40,000	27		23	
10	10	40,000	32		45	
12	12	40,000	27	41	90	110
14	14	40,000	37		110	
16	16	40,000	42		185	
18	18	40,000	42		240	
20	20	40,000	42	48	330	520
25	25	25,000	48		400	
32	32	25,000	55	57	650	900

- Допуск : H6
- Температура : 20~25°C
- Макс. давление охлаждающей жидкости : 80bar



Испытание крутящего момента и утечки гидравлического масла

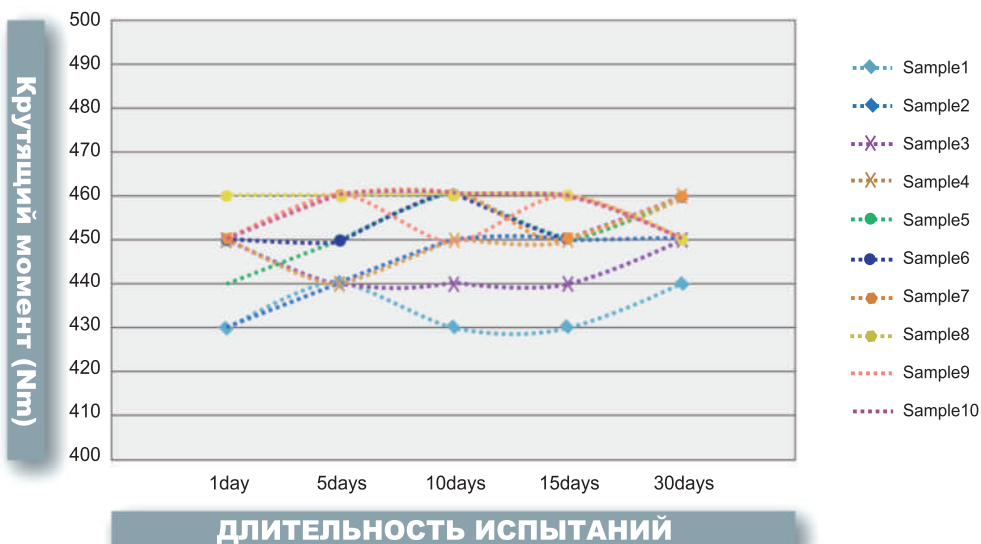

- ТЕСТОВАЯ МОДЕЛЬ : BT40AD/B-NC20-90
- Отсутствие утечки масла в течение длительного периода
- Поддержание стабильного крутящего момента

ТЕХНИЧЕСКАЯ ИНФОРМАЦИЯ ГИДРАВЛИЧЕСКИЙ ПАТРОН



Радиальная регулировка вылета инструмента

- Простая настройка длины вы режущего инструмента (Экономия времени для предварительной установки режущего инструмента на одну пятую по сравнению с обычным гидравлическим патроном)
- Точная регулировка вылета
- Сконструирован так, чтобы регулировочный винт и зажимной винт были разделены

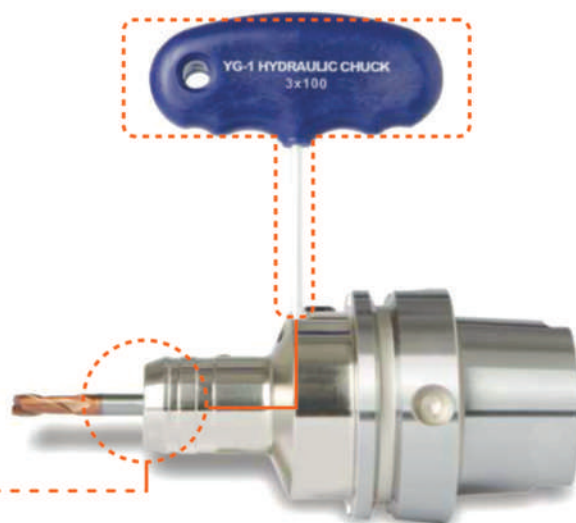

Различная длина настройки вылета: 0~10 мм

ПРИМЕНЕНИЕ

Фрезерование	Высокоскоростная обработка	Чистовое сверление
Развертывание	Резьбонарезание и резьбофрезерование	Снятие фаски

ГИДРАВЛИЧЕСКИЕ ПАТРОНЫ

HCR

(с возможностью предварительной радиальной регулировки вылета инструмента)

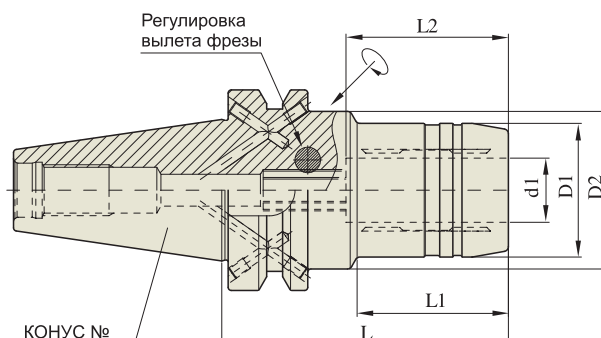

DIN 69871 -SK	Ст. точн. конуса AT3	Балансир. G 2.5	Частота вращ. 25,000	Вылет (при 3D) ≤3U_m	Система охлаждения AD/B
---------------	--------------------------------	---------------------------	--------------------------------	--	-----------------------------------

■ DIN 69871-SK

Ед.изм.: мм

КОНУС No.	МОДЕЛЬ	Артикул	d1	D1	D2	L	L1	L2	ВЕС (Kg)
30	SK30-HCR12-85	P2770001A	12	32	44.5	85	40	37	0.90
	SK30-HCR20-85	P2770003A	20	44	-	85	-	42	1.00
40	SK40AD/B-HCR12-80.5	P2554018	12	32	49.5	80.5	31.5	37	1.50
	SK40AD/B-HCR20-80.5	P2554019	20	42	49.5	80.5	34	42	1.60
	SK40AD/B-HCR32-110	P2770004	32	63	80	110	50	55	2.20
50	SK50AD/B-HCR12-80.5	P2770005	12	32	49.5	80.5	35	37	3.90
	SK50AD/B-HCR20-80.5	P2770006	20	42	44.5	80.5	44	42	4.00
	SK50AD/B-HCR32-100	P2770002	32	60	-	100	-	55	4.70

► Доступны изделия с конусом CAT (ANSI B5.50) и с дюймовой системой измерения.

ГИДРАВЛИЧЕСКИЕ ПАТРОНЫ

ГИДРАВЛИЧЕСКИЕ ПАТРОНЫ (Power E Hydro)

NEW

HCP

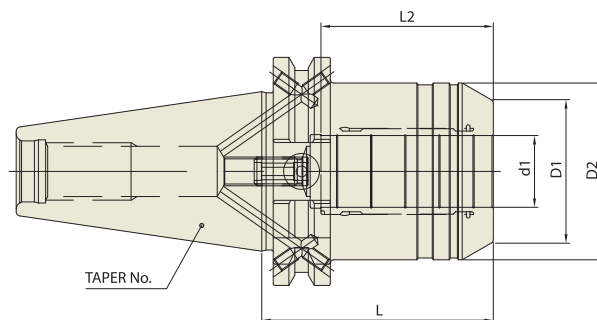

■ DIN 69871-SK

DIN 69871-SK	Taper Accuracy AT3	G Value 2.5	RPM 25,000	Run-Out (at 3D) ≤3Um	Coolant System AD/B
---------------------	------------------------------	-----------------------	----------------------	--------------------------------	-------------------------------

Ед.изм.: мм

КОНУС No.	МОДЕЛЬ	АРТИКУЛ	d1	D1	D2	L	L1	L2	ВЕС (Kg)
40	SK40AD/B-HC12P-50	P2776651P	12	32	42	50	41	M8x1.0	1.00
	SK40AD/B-HC20P-64.5	P2534001P	20	38	49.5	64.5	48	M8x1.0	1.20
50	SK50AD/B-HC20P-64.5	P2756010P	20	38	49.5	64.5	48	M8x1.0	2.80
	SK50AD/B-HC32P-81	P2534002P	32	58.5	72	81	57	M8x1.0	3.90

ГИДРАВЛИЧЕСКИЕ ПАТРОНЫ (ТОНКИЕ)

НС

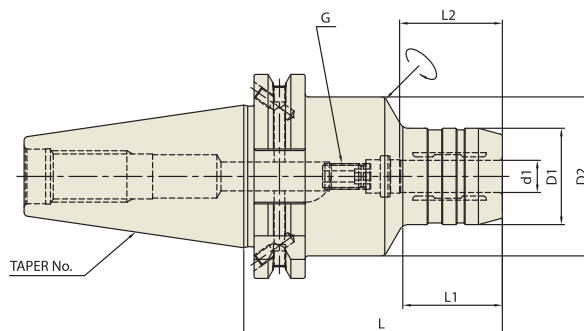

DIN 69871 -SK	Taper Accuracy AT3	G Value 2.5	RPM 25,000	Run-Out (at 3D) ≤3Um	Coolant System AD or AD/B
----------------------	------------------------------	-----------------------	----------------------	--------------------------------	-------------------------------------

■ DIN 69871-SK

КОНУС No.	МОДЕЛЬ	АРТИКУЛ	d1	D1	D2	L	L1	L2	G	БЕС (Kg)
30	SK30-НС6-70	P2770101A	6	26	45	70	20	27	M5x0.8	0.65
	SK30-НС8-70	P2770110A	8	28	45	70	20	27	M6x1.0	0.65
	SK30-НС10-75	P2770102A	10	30	45	75	21	32	M8x1.0	0.73
	SK30-НС12-85	P2770111A	12	32	45	85	40	37	M10x1.0	0.80
	SK30-НС14-85	P2770112A	14	34	45	85	22	37	M10x1.0	0.80
	SK30-НС16-90	P2770113A	16	38	45	90	50	42	M6x1.0	0.90
	SK30-НС18-90	P2770114A	18	40	45	90	50	42	M10x1.0	0.90
40	SK40AD/B-НС6-80.5	P2554017	6	26	49.5	80.5	30	27	M5x0.8	1.31
	SK40AD/B-НС6-110	P2554016	6	26	49.5	110	29.5	27	M5x0.8	1.76
	SK40AD/B-НС8-80.5	P2554025	8	28	49.5	80.5	30	27	M6x1.0	1.34
	SK40AD/B-НС8-110	P2770117	8	28	49.5	110	30	27	M6x1.0	1.76
	SK40AD/B-НС10-80.5	P2554004	10	30	49.5	80.5	31	32	M8x1.0	1.34
	SK40AD/B-НС10-110	P2554009	10	30	49.5	110	31	32	M8x1.0	1.76
	SK40AD/B-НС12-80.5	P2554011	12	32	49.5	80.5	31.5	37	M10x1.0	1.34
	SK40AD/B-НС12-110	P2554010	12	32	49.5	110	31.5	37	M10x1.0	1.76
	SK40AD/B-НС16-80.5	P2554013	16	38	49.5	80.5	33	42	M12x1.0	1.34
	SK40AD/B-НС16-110	P2554012	16	38	49.5	110	33	42	M12x1.0	1.76
	SK40AD/B-НС20-80.5	P2554015	20	42	49.5	80.5	34	42	M16x1.0	1.35
	SK40AD/B-НС20-110	P2554014	20	42	49.5	110	34	42	M16x1.0	1.78
	SK40AD/B-НС25-80.5	P2770103	25	55	66	80.5	22	48	M16x1.0	1.75
SK40AD/B-НС32-80.5	P2770127	32	63	80	80.5	25.5	55	M16x1.0	2.60	
50	SK50AD/B-НС6-80.5	P2770104	6	26	49.5	80.5	30	27	M5x0.8	3.00
	SK50AD/B-НС8-80.5	P2770116	8	28	49.5	80.5	30	27	M6x1.0	3.00
	SK50AD/B-НС10-80.5	P2770106	10	30	49.5	80.5	32	32	M8x1.0	3.00
	SK50AD/B-НС12-80.5	P2770118	12	32	49.5	80.5	35	37	M10x1.0	3.05
	SK50AD/B-НС16-80.5	P2770108	16	38	49.5	80.5	40	42	M12x1.0	3.10
	SK50AD/B-НС20-80.5	P2770119	20	42	49.5	80.5	40	42	M16x1.0	3.15

► Доступны изделия с конусом CAT (ANSI B5.50) и с дюймовой системой измерения.

ГИДРАВЛИЧЕСКИЕ ПАТРОНЫ (УЛЬТРА КОРОТКИЕ)

HC

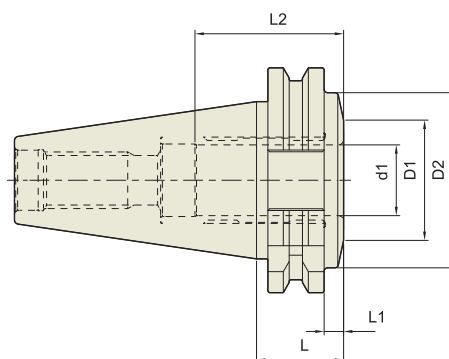

■ DIN 69871-SK

DIN 69871-SK	Taper Accuracy AT3	G Value 2.5	RPM 25,000	Run-Out (at 3D) ≤3Um	Coolant System AD
--------------	-----------------------	----------------	---------------	-------------------------	----------------------

Unit : mm

КОНУС No.	МОДЕЛЬ	АРТИКУЛ	d1	D1	D2	L	L1	L2	G	BEK (Kg)
40	SK40-HC20-24.6	P2770120	20	34	49.5	24.6	5.5	42	-	
50	SK50-HC32-30.9	P2770121	32	44.5	70.5	30.9	11.85	55	-	

► Доступны изделия с конусом CAT (ANSI B5.50) и с дюймовой системой измерения.

ГИДРАВЛИЧЕСКИЕ ПАТРОНЫ (ДЛЯ ПРЕСС-ФОРМ)

HMC

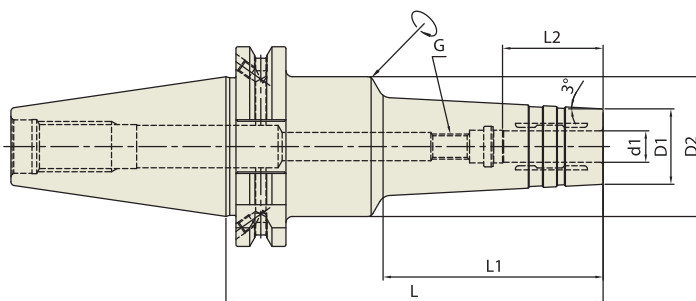

DIN 69871 -SK	Taper Accuracy AT3	G Value 2.5	RPM 25,000	Run-Out (at 3D) ≤3Um	Coolant System AD/B
----------------------	------------------------------	-----------------------	----------------------	--------------------------------	-------------------------------

■ DIN 69871-SK

Unit : mm

КОНУС No.	МОДЕЛЬ	Артикул	d1	D1	D2	L	L1	L2	G	БЕС (Kg)
40	SK40AD/B-HMC6-120	P2770701	6	20	49.5	120	70	27	M5×0.8	1.40
	SK40AD/B-HMC6-150	P2770702	6	20	49.5	150	100	27	M5×0.8	1.65
	SK40AD/B-HMC8-120	P2770703	8	22	49.5	120	70	27	M6×1.0	1.40
	SK40AD/B-HMC8-150	P2770704	8	22	49.5	150	100	27	M6×1.0	1.65
	SK40AD/B-HMC10-120	P2770705	10	24	44.5	120	70	32	M8×1.0	1.40
	SK40AD/B-HMC10-150	P2770706	10	24	44.5	150	100	32	M8×1.0	1.65
	SK40AD/B-HMC12-120	P2770707	12	25	44.5	120	70	37	M10×1.0	1.40
	SK40AD/B-HMC12-150	P2770708	12	25	44.5	150	100	37	M10×1.0	1.65
	SK40AD/B-HMC16-120	P2770709	16	32	49.5	120	70	42	M12×1.0	1.45
	SK40AD/B-HMC16-150	P2770710	16	32	49.5	150	100	42	M12×1.0	1.70
50	SK40AD/B-HMC20-120	P2770711	20	34	49.5	120	70	42	M16×1.0	1.50
	SK40AD/B-HMC20-150	P2770712	20	34	49.5	150	100	42	M16×1.0	1.70
	SK50AD/B-HMC6-150	P2770713	6	20	44.5	150	100	27	M5×0.8	4.50
	SK50AD/B-HMC8-150	P2770714	8	22	44.5	150	100	27	M6×1.0	4.50
	SK50AD/B-HMC10-150	P2770715	10	24	44.5	150	100	32	M8×1.0	4.50
	SK50AD/B-HMC12-150	P2770716	12	25	44.5	150	100	37	M10×1.0	4.50
	SK50AD/B-HMC16-150	P2770717	16	32	44.5	150	100	42	M12×1.0	4.70
	SK50AD/B-HMC20-150	P2770718	20	34	44.5	150	100	42	M16×1.0	5.00

► Доступны изделия с конусом CAT (ANSI B5.50) и с дюймовой системой измерения.

ГИДРАВЛИЧЕСКИЕ ПАТРОНЫ

HCR

(С возможностью предварительной радиальной регулировки вылета инструмента)

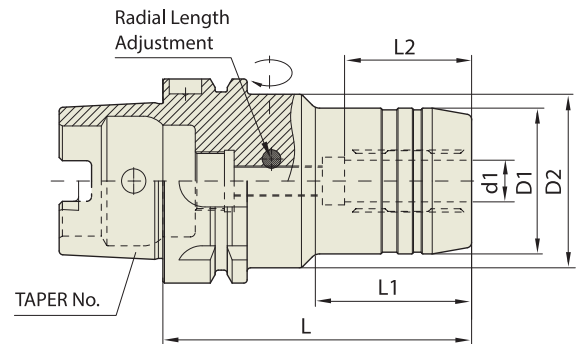

■ DIN 69893/ISO 12164-1-HSK A

DIN 69893 - HSK	Taper Accuracy -	G Value 2.5	RPM 25,000	Run-Out (at 3D) ≤3Um	Coolant System AD
------------------------	----------------------------	-----------------------	----------------------	--------------------------------	-----------------------------

Unit : mm

КОНУС No.	МОДЕЛЬ	АРТИКУЛ	d1	D1	D2	L	L1	L2	BEC (Kg)	
40A	HSK40A-HCR6-80	P2770210	6	26	34	80	36	27	0.55	
	HSK40A-HCR8-80	P2770211	8	28	34	80	36	27	0.55	
	HSK40A-HCR10-85	P2770212	10	30	34	85	43	32	0.65	
	HSK40A-HCR12-90	P2770213	12	32	34	90	48	37	0.70	
50A	HSK50A-HCR6-80	P2770214	6	26	40	80	35	27	0.70	
	HSK50A-HCR8-80	P2770215	8	28	40	80	36	27	0.70	
	HSK50A-HCR10-85	P2770216	10	30	40	85	38	32	0.73	
	HSK50A-HCR12-90	P2770217	12	32	40	90	40	37	0.80	
	HSK50A-HCR14-90	P2770218	14	34	40	90	40	37	0.80	
	HSK50A-HCR16-95	P2770219	16	38	53	95	36.5	42	1.00	
	HSK50A-HCR18-95	P2770220	18	40	57	95	36.5	42	1.00	
	HSK50A-HCR20-100	P2770221	20	42	60	100	39	42	1.10	
	63A	HSK63A-HCR6-80	P2770205	6	26	50	80	33	27	0.96
		HSK63A-HCR8-80	P2770206	8	28	50	80	33	27	0.98
HSK63A-HCR10-85		P2770207	10	30	50	85	38	32	1.04	
HSK63A-HCR12-90		P2567011	12	32	50	90	40	37	1.06	
HSK63A-HCR14-90		P2770202	14	34	50	90	46	37	1.08	
HSK63A-HCR16-95		P2770209	16	38	50	95	51	42	1.18	
HSK63A-HCR18-95		P2770203	18	40	50	95	52	42	1.20	
HSK63A-HCR20-100		P2567012	20	42	50	100	51	42	1.22	
HSK63A-HCR25-120		P2770204	25	57	63	120	54.5	48	2.20	
HSK63A-HCR32-125		P2770201	32	64	75	125	57.5	55	2.60	
100A	HSK100A-HCR6-85	P2770222	6	26	63	85	33	27	3.60	
	HSK100A-HCR8-85	P2770223	8	28	63	85	33	27	3.60	
	HSK100A-HCR10-90	P2770224	10	30	63	90	36	32	3.80	
	HSK100A-HCR12-95	P2770225	12	32	63	95	40	37	3.80	
	HSK100A-HCR14-95	P2770226	14	34	63	95	41	37	3.80	
	HSK100A-HCR16-100	P2770227	16	38	63	100	46	42	3.90	
	HSK100A-HCR18-100	P2770228	18	40	63	100	46	42	3.90	
	HSK100A-HCR20-105	P2770229	20	42	75	105	51	42	4.20	
	HSK100A-HCR25-115	P2770230	25	57	75	115	55.5	48	4.40	
	HSK100A-HCR32-120	P2770231	32	64	75	120	63.5	55	4.60	

ГИДРАВЛИЧЕСКИЕ ПАТРОНЫ (Power E Hydro) **NEW**

НСП

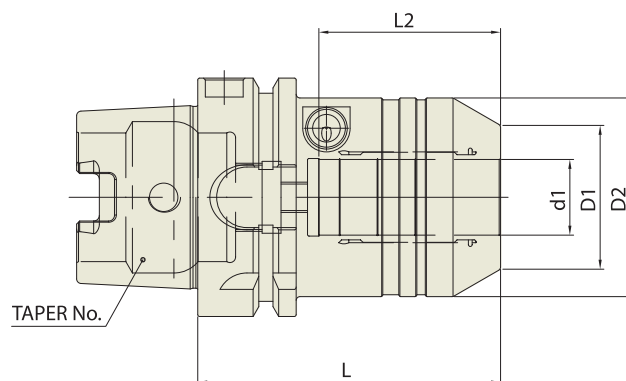

DIN 69893 - HSK	Taper Accuracy -	G Value 2.5	RPM 25,000	Run-Out (at 3D) ≤3Um	Coolant System AD
------------------------	----------------------------	-----------------------	----------------------	--------------------------------	-----------------------------

69893/ISO 12164-1-HSK ФОРМА А

Unit : mm

КОНУС No.	МОДЕЛЬ	АРТИКУЛ	d1	D1	D2	L	L2	G	ВЕС (Kg)
63A	HSK63A-НС12P-80	P2770302P	12	32	42	80	41	M8x1.0	1.20
	HSK63A-НС20P-80	P2770301P	20	38	52.5	80	48	M8x1.0	1.30
100A	HSK100A-НС20P-90	P2770303P	20	38	52.5	90	48	M8x1.0	2.80
	HSK100A-НС32P-100	P2770304P	32	58.5	72	100	57	M8x1.0	3.70

ГИДРАВЛИЧЕСКИЕ ПАТРОНЫ (ТОНКИЕ)

НС

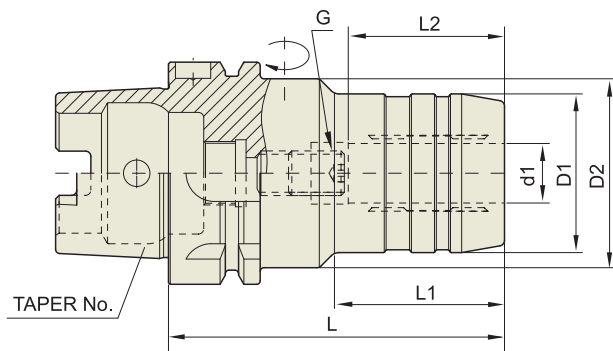
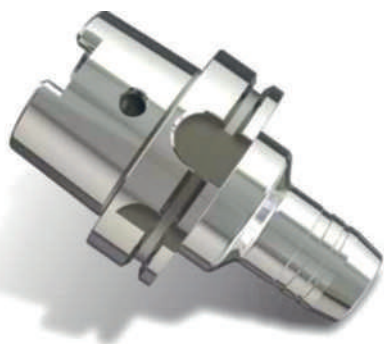

■ DIN 69893/ISO 12164-1-HSK ФОРМА А

DIN 69893 - HSK	Taper Accuracy -	G Value 2.5	RPM 25,000	Run-Out (at 3D) ≤3Um	Coolant System AD
------------------------	----------------------------	-----------------------	----------------------	--------------------------------	-----------------------------

Unit : mm

КОНУС No.	МОДЕЛЬ	АРТИКУЛ	d1	D1	D2	L	L1	L2	G	БЕС (Kg)
32A	HSK32A-НС6-80	P2770413	6	26	40	80	29	27	M5×0.8	0.30
	HSK32A-НС8-80	P2770414	8	28	40	80	29	27	M6×1.0	0.30
	HSK32A-НС10-85	P2770415	10	30	40	85	35	32	M6×1.0	0.30
	HSK32A-НС12-90	P2770416	12	32	40	90	40	37	M6×1.0	0.30
40A	HSK40A-НС6-70	P2770401	6	26	34	70	36	27	M5×0.8	0.50
	HSK40A-НС8-70	P2770402	8	28	34	70	36	27	M6×1.0	0.50
	HSK40A-НС10-75	P2770403	10	30	34	75	42	32	M6×1.0	0.60
	HSK40A-НС12-80	P2770417	12	32	34	80	48	37	M6×1.0	0.65
50A	HSK50A-НС6-70	P2770404	6	26	40	70	28	27	M5×0.8	0.65
	HSK50A-НС8-70	P2770405	8	28	40	70	28	27	M6×1.0	0.65
	HSK50A-НС10-75	P2770406	10	30	40	75	34	32	M8×1.0	0.70
	HSK50A-НС12-85	P2770407	12	32	40	85	44	37	M10×1.0	0.75
	HSK50A-НС14-85	P2770408	14	34	40	85	43	37	M10×1.0	0.75
	HSK50A-НС16-90	P2770409	16	38	53	90	30	42	M12×1.0	0.90
	HSK50A-НС18-90	P2770418	18	40	57	90	30	42	M12×1.0	0.90
63A	HSK63A-НС6-70	P2567001	6	26	50	70	24	27	M5×0.8	0.53
	HSK63A-НС8-70	P2567002	8	28	50	70	25	27	M6×1.0	0.55
	HSK63A-НС10-80	P2567003	10	30	50	80	35	32	M8×1.0	1.00
	HSK63A-НС12-85	P2567004	12	32	50	85	40	37	M10×1.0	1.03
	HSK63A-НС14-85	P2567005	14	34	50	85	40	37	M10×1.0	1.05
	HSK63A-НС16-90	P2567006	16	38	50	90	46	42	M12×1.0	1.15
	HSK63A-НС18-90	P2567007	18	40	50	90	47	42	M12×1.0	1.15
	HSK63A-НС20-90	P2567008	20	42	50	90	48	42	M16×1.0	1.20
	HSK63A-НС25-120	P2567009	25	57	63	120	59	48	M16×1.0	2.20
	HSK63A-НС32-125	P2567010	32	64	75	125	63	55	M16×1.0	2.40
80A	HSK80A-НС12-85	P2770462	12	32	50	85	40	37	M10×1.0	1.60
	HSK80A-НС20-95	P2770463	20	42	50	95	52	42	M16×1.0	1.80
	HSK80A-НС32-125	P2770464	32	64	75	125	63	55	M16×1.0	3.30
100A	HSK100A-НС6-75	P2770420	6	26	50	75	26	27	M5×0.8	3.20
	HSK100A-НС8-75	P2770421	8	28	50	75	26	27	M6×1.0	3.20
	HSK100A-НС10-90	P2770422	10	30	50	90	42	32	M8×1.0	3.40
	HSK100A-НС12-95	P2770410	12	32	50	95	47	37	M10×1.0	3.40
	HSK100A-НС14-95	P2770423	14	34	50	95	47	37	M10×1.0	3.40
	HSK100A-НС16-100	P2770411	16	38	50	100	53	42	M12×1.0	3.50
	HSK100A-НС18-100	P2770424	18	40	50	100	53	42	M12×1.0	3.60
	HSK100A-НС20-105	P2757010	20	42	50	105	59	42	M16×1.0	4.00
	HSK100A-НС25-110	P2770412	25	57	63	110	62	48	M16×1.0	4.20
	HSK100A-НС32-110	P2757020	32	64	75	110	62	55	M16×1.0	4.30

ГИДРАВЛИЧЕСКИЕ ПАТРОНЫ (ТОНКИЕ)

НС

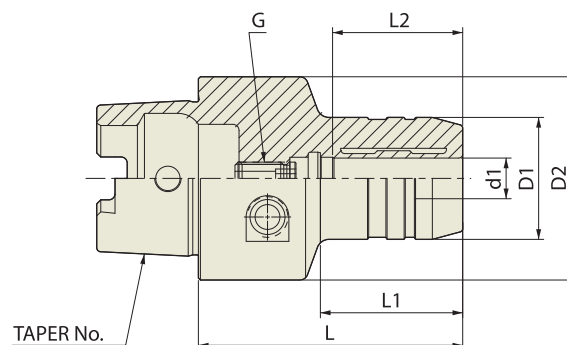

DIN 69893 - HSK	Taper Accuracy -	G Value 2.5	RPM 25,000	Run-Out (at 3D) ≤3Um	Coolant System AD
-----------------	---------------------	----------------	---------------	-------------------------	----------------------

■ DIN 69893/ISO 12164-1-HSK ФОРМА C

Unit : mm

КОНУС No.	МОДЕЛЬ	АРТИКУЛ	d1	D1	D2	L	L1	L2	G	ВЕС (Kg)
32C	HSK32C-HC6-65	P2770425	6	26	32	65	30	27	M5x0.8	
	HSK32C-HC8-70	P2770426	8	28	32	70	34	27	M6x1.0	
	HSK32C-HC10-75	P2770427	10	30	32	75	39	32	M6x1.0	
	HSK32C-HC12-80	P2770428	12	32	32	80	-	37	M6x1.0	
40C	HSK40C-HC6-60	P2770429	6	26	40	60	36	27	M5x0.8	
	HSK40C-HC8-60	P2770430	8	28	40	60	36	27	M6x1.0	
	HSK40C-HC10-65	P2770431	10	30	40	65	41	32	M6x1.0	
	HSK40C-HC12-70	P2770432	12	32	40	70	47	37	M6x1.0	
50C	HSK50C-HC6-60	P2770433	6	26	50	60	30	27	M5x0.8	
	HSK50C-HC8-60	P2770434	8	28	50	60	30	27	M6x1.0	
	HSK50C-HC10-65	P2770435	10	30	50	65	35	32	M8x1.0	
	HSK50C-HC12-75	P2770436	12	32	50	75	44	37	M10x1.0	
	HSK50C-HC14-75	P2770437	14	34	50	75	46	37	M10x1.0	
	HSK50C-HC16-80	P2770438	16	38	50	80	51	42	M12x1.0	
63C	HSK50C-HC18-80	P2770439	18	40	50	80	51	42	M12x1.0	
	HSK50C-HC20-80	P2770440	20	42	50	80	48	42	M16x1.0	
	HSK63C-HC6-60	P2770441	6	26	63	60	25	27	M5x0.8	
	HSK63C-HC8-60	P2770442	8	28	63	60	25	27	M6x1.0	
	HSK63C-HC10-65	P2770443	10	30	63	65	31	32	M8x1.0	
	HSK63C-HC12-75	P2770444	12	32	63	75	41	37	M10x1.0	
	HSK63C-HC14-75	P2770445	14	34	63	75	40	37	M10x1.0	
	HSK63C-HC16-80	P2770446	16	38	63	80	48	42	M12x1.0	
	HSK63C-HC18-80	P2770447	18	40	63	80	47	42	M12x1.0	
	HSK63C-HC20-80	P2770448	20	42	63	80	49	42	M16x1.0	
	HSK63C-HC25-95	P2770449	25	57	63	95	63	48	M16x1.0	
	HSK63C-HC32-100	P2770450	32	63	63	100	-	55	M16x1.0	

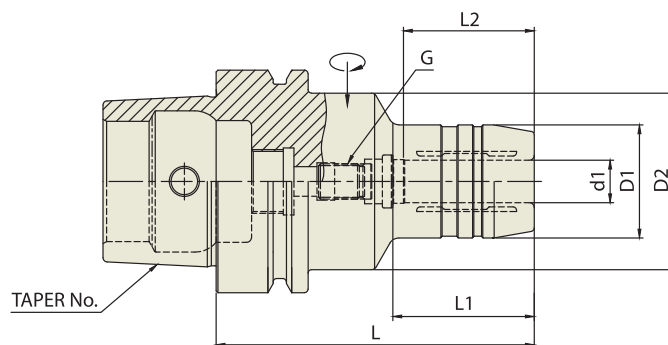

■ DIN 69893/ISO 12164-1-HSK ФОРМА E И F

DIN 69893 - HSK	Taper Accuracy -	G Value 2.5	RPM 25,000	Run-Out (at 3D) ≤3Um	Coolant System AD
------------------------	----------------------------	-----------------------	----------------------	--------------------------------	-----------------------------

Unit : mm

КОНУС No.	МОДЕЛЬ	АРТИКУЛ	d1	D1	D2	L	L1	L2	G	БЕС (Kg)
40E	HSK40E-HC6-70	P2770451	6	26	34	70	36	27	M5x0.8	
	HSK40E-HC8-70	P2770452	8	28	34	70	36	27	M6x1.0	
	HSK40E-HC10-75	P2770453	10	30	34	75	42	32	M6x1.0	
	HSK40E-HC12-80	P2770454	12	32	34	80	48	37	M6x1.0	
50E	HSK50E-HC6-70	P2770455	6	26	40	70	28	27	M5x0.8	
	HSK50E-HC8-70	P2770456	8	28	40	70	28	27	M6x1.0	
	HSK50E-HC10-75	P2770457	10	30	40	75	34	32	M8x1.0	
	HSK50E-HC12-85	P2770458	12	32	40	85	44	37	M10x1.0	
	HSK50E-HC16-90	P2770459	16	38	53	90	30	42	M12x1.0	
	HSK50E-HC20-90	P2770460	20	42	60	90	29	42	M16x1.0	
63F	HSK63F-HC20-85	P2770461	20	42	50	85	46	42	M12x1.0	

ГИДРАВЛИЧЕСКИЕ ПАТРОНЫ (ДЛЯ ПРЕСС-ФОРМ)

HMC

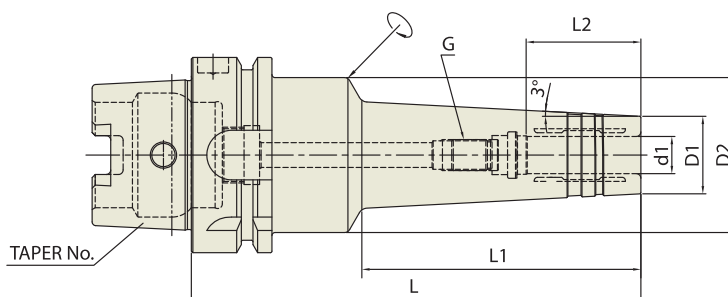

■ DIN 69893/ISO 12164-1-HSK ФОРМА А

DIN 69893 - HSK	Taper Accuracy -	G Value 2.5	RPM 25,000	Run-Out (at 3D) ≤3Um	Coolant System AD
------------------------	----------------------------	-----------------------	----------------------	--------------------------------	-----------------------------

Unit : mm

КОНУС No.	МОДЕЛЬ	Артикул	d1	D1	D2	L	L1	L2	G	ВЕС (Kg)
63A	HSK63A-HMC6-145	P2770801	6	20	50	145	90	27	M5×0.8	1.40
	HSK63A-HMC8-145	P2770802	8	22	50	145	90	27	M6×1.0	1.40
	HSK63A-HMC10-145	P2770803	10	24	50	145	90	32	M8×1.0	1.40
	HSK63A-HMC12-145	P2770804	12	25	50	145	90	37	M10×1.0	1.40
	HSK63A-HMC16-145	P2770805	16	32	50	145	90	42	M12×1.0	1.45
	HSK63A-HMC20-145	P2770806	20	34	50	145	90	42	M16×1.0	1.50
100A	HSK100A-HMC6-150	P2770812	6	20	50	150	90	27	M5×0.8	4.50
	HSK100A-HMC8-150	P2770807	8	22	50	150	90	27	M6×1.0	4.50
	HSK100A-HMC10-150	P2770808	10	24	50	150	90	32	M8×1.0	4.50
	HSK100A-HMC12-150	P2770809	12	25	50	150	90	37	M10×1.0	4.50
	HSK100A-HMC16-150	P2770810	16	32	50	150	90	42	M12×1.0	4.70
	HSK100A-HMC20-150	P2770811	20	34	50	150	90	42	M16×1.0	5.00

ГИДРАВЛИЧЕСКИЕ ПАТРОНЫ

HCR

(С возможностью предварительной радиальной регулировки вылета инструмента)

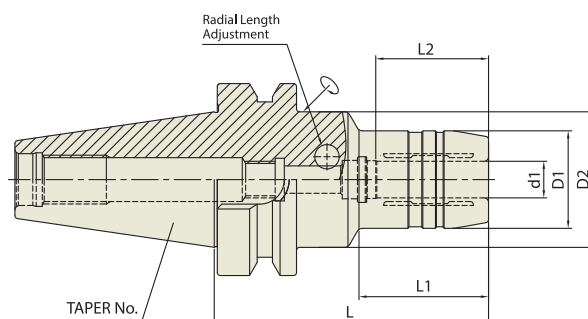

■ **CBT (BT ДВОЙНОЙ КОНТАКТ)**

CBT	Taper Accuracy AT3	G Value 2.5	RPM 25,000	Run-Out (at 3D) ≤3Um	Coolant System AD
-----	------------------------------	-----------------------	----------------------	--------------------------------	-----------------------------

Unit : mm

КОНУС No.	МОДЕЛЬ	Артикул	d1	D1	D2	L	L1	L2	БЕС (Kg)
30	CBT30-HCR12-85	P2770551	12	32	44.5	85	40	37	0.90
	CBT30-HCR20-85	P2770552	20	44	44	85	-	42	1.00
40	CBT40-HCR12-90	P2770553	12	32	44.5	90	42.5	37	1.50
	CBT40-HCR20-90	P2770554	20	42	44.5	90	47.5	42	1.60
	CBT40-HCR32-105	P2770555	32	60	60	105	-	55	2.20
50	CBT50-HCR12-95	P2770556	12	32	44.5	95	34	37	3.90
	CBT50-HCR20-100	P2770557	20	42	44.5	100	44	42	4.00
	CBT50-HCR32-115	P2770558	32	60	60	115	-	55	4.10

ГИДРАВЛИЧЕСКИЕ ПАТРОНЫ

HCR

(С возможностью предварительной радиальной регулировки вылета инструмента)

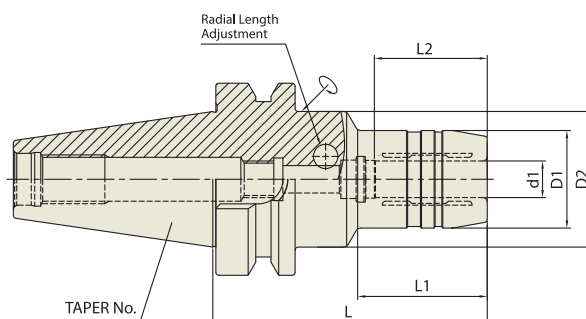

JIS B6339/MAS 403-BT

JIS B6339 -BT	Taper Accuracy AT3	G Value 2.5	RPM 25,000	Run-Out (at 3D) ≤3Um	Coolant System AD or AD/B
----------------------	------------------------------	-----------------------	----------------------	--------------------------------	-------------------------------------

Unit : mm

КОНУС No.	МОДЕЛЬ	Артикул	d1	D1	D2	L	L1	L2	БЕС (Kg)
30	BT30-HCR12-85	P2777102A	12	32	44.5	85	40	37	0.90
	BT30-HCR20-85	P2777103A	20	44	44	85	-	42	1.00
40	BT40AD/B-HCR12-90	P2777104	12	32	44.5	90	42.5	37	1.50
	BT40AD/B-HCR20-90	P2554008	20	42	44.5	90	47.5	42	1.60
	BT40AD/B-HCR32-105	P2777105	32	60	60	105	-	55	2.20
50	BT50AD/B-HCR12-95	P2777106A	12	32	44.5	95	34	37	3.90
	BT50AD/B-HCR20-100	P2777101	20	42	44.5	100	44	42	4.00
	BT50AD/B-HCR32-115	P2777107	32	60	60	115	-	55	4.10

► Доступны изделия с конусом CAT (ANSI B5.50) и с дюймовой системой измерения.

ГИДРАВЛИЧЕСКИЕ ПАТРОНЫ

ГИДРАВЛИЧЕСКИЕ ПАТРОНЫ (ТОНКИЕ)

HC

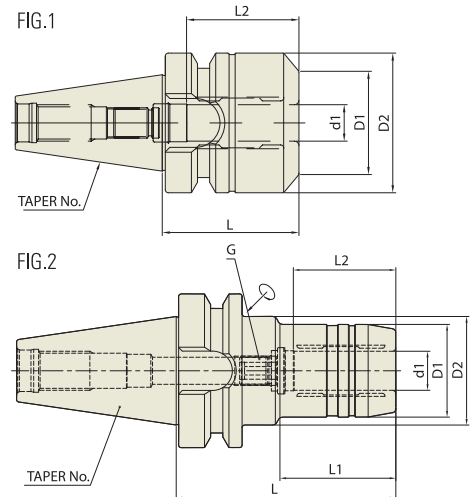

CBT (BT ДВОЙНОЙ КОНТАКТ)

CBT	Taper Accuracy AT3	G Value 2.5	RPM 25,000	Run-Out (at 3D) ≤3Um	Coolant System AD
-----	------------------------------	-----------------------	----------------------	--------------------------------	-----------------------------

Unit : mm

КОНУС No.	МОДЕЛЬ	АРТИКУЛ	d1	D1	D2	L	L1	L2	G	FIG.	BEC (Kg)
30	CBT30-HC6-45	P2770559	6	46	46	45	-	27	M5x0.8	1	1.50
	CBT30-HC8-45	P2770560	8	46	46	45	-	27	M6x1.0	1	1.50
	CBT30-HC10-45	P2770561	10	46	46	45	-	32	M8x1.0	1	1.50
	CBT30-HC12-45	P2770562	12	46	46	45	-	37	M10x1.0	1	1.50
	CBT30-HC16-45	P2770563	16	46	46	45	-	42	M10x1.0	1	1.50
	CBT30-HC20-60	P2770564	20	53	53	60	-	42	M10x1.0	1	2.10
	CBT30-HC6-70	P2770503	6	26	44.5	70	29.5	27	M5x0.8	2	0.65
	CBT30-HC8-70	P2770504	8	28	44.5	70	30	27	M6x1.0	2	0.65
	CBT30-HC10-75	P2770505	10	30	44.5	75	31	32	M8x1.0	2	0.73
	CBT30-HC12-85	P2770506	12	32	45	85	45	37	M10x1.0	2	0.80
	CBT30-HC14-85	P2770507	14	34	45	85	45	37	M10x1.0	2	0.80
	CBT30-HC16-90	P2770508	16	38	45	90	50	42	M10x1.0	2	0.90
CBT30-HC18-90	P2770509	18	40	45	90	50	42	M10x1.0	2	0.90	
CBT30-HC20-90	P2770510	20	42	45	90	50	42	M6x1.0	2	0.90	
40	CBT40-HC6-90	P2770511	6	26	44.5	90	43	27	M5x0.8	2	1.30
	CBT40-HC8-90	P2770512	8	28	44.5	90	44.5	27	M6x1.0	2	1.30
	CBT40-HC10-90	P2770513	10	30	44.5	90	44.5	32	M8x1.0	2	1.35
	CBT40-HC12-90	P2770501	12	32	44.5	90	44.5	37	M10x1.0	2	1.35
	CBT40-HC14-90	P2770514	14	34	44.5	90	44.5	37	M10x1.0	2	1.35
	CBT40-HC16-90	P2770515	16	38	44.5	90	47.5	42	M12x1.0	2	1.40
	CBT40-HC18-90	P2770516	18	40	44.5	90	47.5	42	M12x1.0	2	1.45
	CBT40-HC20-90	P2770502	20	42	44.5	90	47.5	42	M16x1.0	2	1.50
	CBT40-HC25-100	P2770517	25	50	60	100	47.5	48	M16x1.0	2	1.70
	CBT40-HC32-105	P2770518	32	60	60	105	-	55	M16x1.0	2	2.10

ГИДРАВЛИЧЕСКИЕ ПАТРОНЫ (ТОНКИЕ)

НС

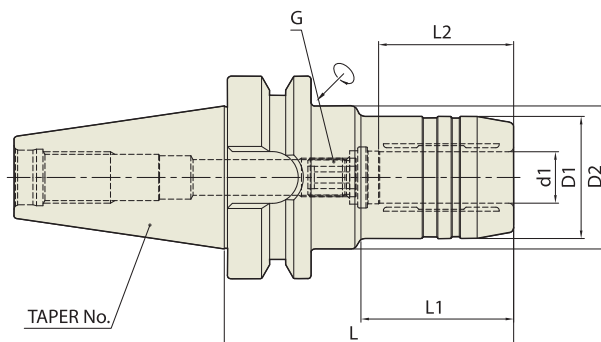

■ СВТ (ВТ ДВОЙНОЙ КОНТАКТ)

СВТ	Taper Accuracy AT3	G Value 2.5	RPM 25,000	Run-Out (at 3D) ≤3Um	Coolant System AD
-----	------------------------------	-----------------------	----------------------	--------------------------------	-----------------------------

Unit : mm

КОНУС No.	МОДЕЛЬ	АРТИКУЛ	d1	D1	D2	L	L1	L2	G	ВЕС (Kg)
50	СВТ50-НС6-90	P2770519	6	26	44.5	90	34	27	M5×0.8	3.75
	СВТ50-НС6-120	P2770520	6	26	44.5	120	34	27	M5×0.8	4.10
	СВТ50-НС6-150	P2770521	6	26	44.5	150	34	27	M5×0.8	4.70
	СВТ50-НС8-90	P2770522	8	28	44.5	90	34	27	M6×1.0	3.75
	СВТ50-НС8-120	P2770523	8	28	44.5	120	34	27	M6×1.0	4.10
	СВТ50-НС8-150	P2770524	8	28	44.5	150	34	27	M6×1.0	4.10
	СВТ50-НС10-90	P2770525	10	30	44.5	90	34	32	M8×1.0	3.90
	СВТ50-НС10-120	P2770526	10	30	44.5	120	34	32	M8×1.0	4.30
	СВТ50-НС10-150	P2770527	10	30	44.5	150	34	32	M8×1.0	4.90
	СВТ50-НС12-90	P2770528	12	32	44.5	90	34	37	M10×1.0	3.90
	СВТ50-НС12-120	P2770529	12	32	44.5	120	34	37	M10×1.0	4.30
	СВТ50-НС12-150	P2770530	12	32	44.5	150	34	37	M10×1.0	4.90
	СВТ50-НС14-90	P2770531	14	34	44.5	90	34	37	M10×1.0	3.90
	СВТ50-НС14-120	P2770532	14	34	44.5	120	34	37	M10×1.0	4.30
	СВТ50-НС14-150	P2770533	14	34	44.5	150	34	37	M10×1.0	4.90
	СВТ50-НС16-90	P2770534	16	38	44.5	90	34	42	M12×1.0	4.00
	СВТ50-НС16-120	P2770535	16	38	44.5	120	34	42	M12×1.0	4.40
	СВТ50-НС16-150	P2770536	16	38	44.5	150	34	42	M12×1.0	5.00
	СВТ50-НС18-90	P2770537	18	40	44.5	90	34	42	M12×1.0	4.00
	СВТ50-НС18-120	P2770538	18	40	44.5	120	34	42	M12×1.0	4.40
СВТ50-НС18-150	P2770539	18	40	44.5	150	34	42	M12×1.0	5.00	
СВТ50-НС20-90	P2770540	20	42	44.5	90	34	42	M16×1.0	4.00	
СВТ50-НС20-120	P2770541	20	42	44.5	120	34	42	M16×1.0	4.40	
СВТ50-НС20-150	P2770542	20	42	44.5	150	34	42	M16×1.0	5.00	
СВТ50-НС25-105	P2770543	25	57	63	105	52	48	M16×1.0	4.40	
СВТ50-НС25-150	P2770544	25	57	63	150	97	48	M16×1.0	5.60	
СВТ50-НС32-115	P2770545	32	64	75	115	62	55	M16×1.0	4.70	
СВТ50-НС32-150	P2770546	32	64	75	150	97	55	M16×1.0	6.00	

ГИДРАВЛИЧ. ПАТРОНЫ
ТЕРМОСТАБИЛИЗ. СПРАВКИ
ЦАНГОВЫЕ ПАТРОНЫ EN
ДЕТЖАВКИ ДЛЯ КОНЦ. ФРЕЗ И С. ФРЕЗ ИЛИ ПЛАН.
СПРАВКИ ДЛЯ ТОЧНОГО МАКСИМАЛ. ФРЕЗ
ФРЕЗЕРНЫЕ ПАТРОНЫ
СПРАВКИ С КОНУСНОМ. МОДЕЛ.
ТОНКИЕ ЦАНГОВЫЕ ПАТРОНЫ EN
РЕЗЬБОНАРЕЗНЫЕ ПАТРОНЫ КРУГЛЫЕ
РЕЗЬБОНАРЕЗНЫЕ ПАТРОНЫ EN
СПРАВКИ ДЛЯ ТОЧНЫХ ФРЕЗ
СВЕТЛЫЕ ПАТРОНЫ ДЛЯ СТАНКА С ЧПУ
РАСТОЧНЫЕ СИСТЕМЫ
ПРОЧЕЕ

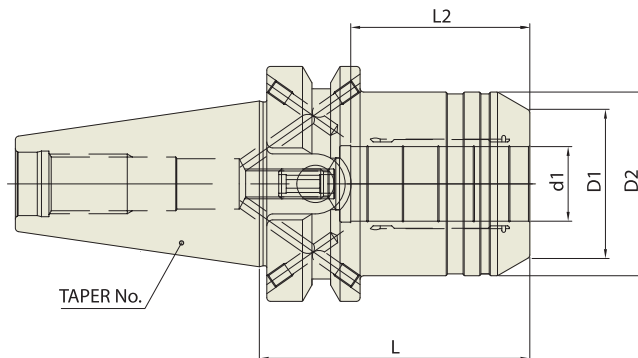

■ JIS B6339/MAS 403-BT

JIS B6339 - BT	Taper Accuracy AT3	G Value 2.5	RPM 25,000	Run-Out (at 3D) ≤3Um	Coolant System AD or AD/B
-----------------------	------------------------------	-----------------------	----------------------	--------------------------------	-------------------------------------

Unit : mm

КОНУС No.	МОДЕЛЬ	АРТИКУЛ	d1	D1	D2	L	L2	G	БЕС (Kg)
30	BT30-HC12P-69	P2776604P	12	32	42	69	41	M8x1.0	0.80
	BT30-HC20P-90	P2776602P	20	38	42	90	48	M8x1.0	0.90
40	BT40AD/B-HC12P-58	P2776601P	12	32	42	58	41	M8x1.0	1.10
	BT40AD/B-HC20P-72.5	P2554001P	20	38	49.25	72.5	48	M8x1.0	1.40
50	BT50AD/B-HC20P-83.5	P2755010P	20	38	49.25	83.5	48	M8x1.0	3.90
	BT50AD/B-HC32P-90	P2558001P	32	58.5	72	90	57	M8x1.0	4.60

► Доступны изделия с конусом CAT (ANSI B5.50) и с дюймовой системой измерения.

ГИДРАВЛИЧЕСКИЕ ПАТРОНЫ (ТОНКИЕ)

НС

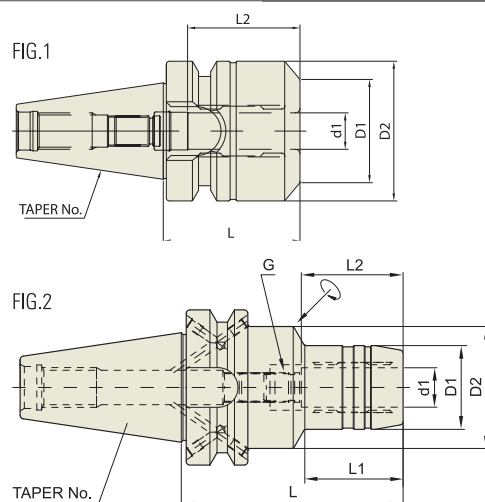

JIS B6339 - BT	Taper Accuracy AT3	G Value 2.5	RPM 25,000	Run-Out (at 3D) ≤3Um	Coolant System AD or AD/B
-----------------------	------------------------------	-----------------------	----------------------	--------------------------------	-------------------------------------

JIS B6339/MAS 403-BT

Unit : mm

КОНУС No.	МОДЕЛЬ	АРТИКУЛ	d1	D1	D2	L	L1	L2	G	FIG.	БЕС (Kg)
30	BT30-НС6-45	P2770643A	6	46	46	45	-	27	M5x0.8	1	1.50
	BT30-НС8-45	P2770644A	8	46	46	45	-	27	M6x1.0	1	1.50
	BT30-НС10-45	P2770645A	10	46	46	45	-	32	M8x1.0	1	1.50
	BT30-НС12-45	P2770646A	12	46	46	45	-	37	M10x1.0	1	1.50
	BT30-НС16-45	P2770647A	16	46	46	45	-	42	M10x1.0	1	1.50
	BT30-НС20-60	P2770648A	20	53	53	60	-	42	M10x1.0	1	2.10
	BT30-НС6-70	P2770604A	6	26	44.5	70	29.5	27	M5x0.8	1	0.65
	BT30-НС8-70	P2770605A	8	28	44.5	70	30	27	M6x1.0	2	0.65
	BT30-НС10-75	P2770606A	10	30	44.5	75	31	32	M8x1.0	2	0.73
	BT30-НС12-85	P2770607A	12	32	45	85	45	37	M10x1.0	2	0.80
	BT30-НС14-85	P2770608A	14	34	45	85	45	37	M10x1.0	2	0.80
	BT30-НС16-90	P2770601A	16	38	45	90	50	42	M10x1.0	2	0.90
BT30-НС18-90	P2770609A	18	40	45	90	50	42	M10x1.0	2	0.90	
BT30-НС20-90	P2770602A	20	42	45	90	50	42	M6x1.0	2	0.90	
40	BT40AD/B-НС6-90	P2554003	6	26	44.5	90	43	27	M5x0.8	2	1.30
	BT40AD/B-НС8-90	P2554021	8	28	44.5	90	44.5	27	M6x1.0	2	1.30
	BT40AD/B-НС10-90	P2554005	10	30	44.5	90	44.5	32	M8x1.0	2	1.35
	BT40AD/B-НС12-90	P2554002	12	32	44.5	90	44.5	37	M10x1.0	2	1.35
	BT40AD/B-НС14-90	P2770610	14	34	44.5	90	44.5	37	M10x1.0	2	1.35
	BT40AD/B-НС16-90	P2554006	16	38	44.5	90	47.5	42	M12x1.0	2	1.40
	BT40AD/B-НС18-90	P2770611	18	40	44.5	90	47.5	42	M12x1.0	2	1.45
	BT40AD/B-НС20-90	P2554007	20	42	44.5	90	47.5	42	M16x1.0	2	1.50
	BT40AD/B-НС25-100	P2770641	25	50	60	100	47.5	48	M16x1.0	2	1.70
	BT40AD/B-НС32-105	P2770612	32	60	-	105	-	55	M16x1.0	2	2.10

► Доступны изделия с конусом CAT (ANSI B5.50) и с дюймовой системой измерения.

ГИДРАВЛИЧ. ПАТРОНЫ
ТЕРМОСТАТИЧ. ПАТРОНЫ
ЦАНГОВЫЕ ПАТРОНЫ И
ДЕРЖАВКИ ДЛЯ КОНЦ. ФРЕЗ И
ОТРАВКИ ДЛЯ ТОКАРНО-МАСШТАБ. ФРЕЗ
ФРЕЗЕРНЫЕ ПАТРОНЫ
ОТРАВКИ С КОНУСОМ
ТОНИКОВЫЕ ПАТРОНЫ И
РЕЗЬБОНАРЕЗНЫЕ ПАТРОНЫ
РЕЗЬБОНАРЕЗНЫЕ ПАТРОНЫ
ОТРАВКИ ДЛЯ ТОКАРНЫХ
СВЕРЛИЛЬНЫЕ ПАТРОНЫ
РАСТОЧНЫЕ СИСТЕМЫ
ПРОЧЕЕ

ГИДРАВЛИЧЕСКИЕ ПАТРОНЫ

ГИДРАВЛИЧЕСКИЕ ПАТРОНЫ (ТОНКИЕ)

НС

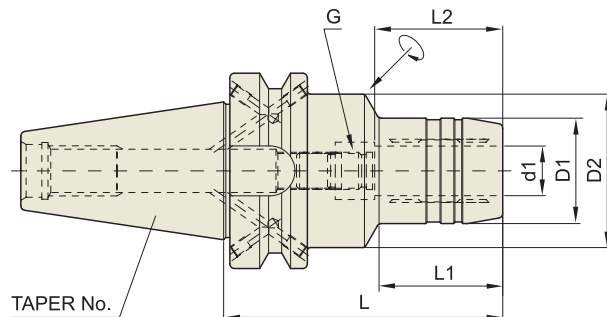

JIS B6339/MAS 403-BT

JIS B6339 - BT	Taper Accuracy AT3	G Value 2.5	RPM 25,000	Run-Out (at 3D) ≤3Um	Coolant System AD/B
-----------------------	------------------------------	-----------------------	----------------------	--------------------------------	-------------------------------

Unit : mm

КОНУС No.	МОДЕЛЬ	Артикул	d1	D1	D2	L	L1	L2	G	БЕС (Kg)
50	BT50AD/B-НС6-90	P2770613	6	26	44.5	90	34	27	M5×0.8	3.75
	BT50AD/B-НС6-120	P2770614	6	26	44.5	120	34	27	M5×0.8	4.10
	BT50AD/B-НС6-150	P2770615	6	26	44.5	150	34	27	M5×0.8	4.70
	BT50AD/B-НС8-90	P2770616	8	28	44.5	90	34	27	M6×1.0	3.75
	BT50AD/B-НС8-120	P2770617	8	28	44.5	120	34	27	M6×1.0	4.10
	BT50AD/B-НС8-150	P2770618	8	28	44.5	150	34	27	M6×1.0	4.10
	BT50AD/B-НС10-90	P2770619	10	30	44.5	90	34	32	M8×1.0	3.90
	BT50AD/B-НС10-120	P2770620	10	30	44.5	120	34	32	M8×1.0	4.30
	BT50AD/B-НС10-150	P2770621	10	30	44.5	150	34	32	M8×1.0	4.90
	BT50AD/B-НС12-90	P2770622	12	32	44.5	90	34	37	M10×1.0	3.90
	BT50AD/B-НС12-120	P2770623	12	32	44.5	120	34	37	M10×1.0	4.30
	BT50AD/B-НС12-150	P2770624	12	32	44.5	150	34	37	M10×1.0	4.90
	BT50AD/B-НС14-90	P2770625	14	34	44.5	90	34	37	M10×1.0	3.90
	BT50AD/B-НС14-120	P2770626	14	34	44.5	120	34	37	M10×1.0	4.30
	BT50AD/B-НС14-150	P2770627	14	34	44.5	150	34	37	M10×1.0	4.90
	BT50AD/B-НС16-90	P2770628	16	38	44.5	90	34	42	M12×1.0	4.00
	BT50AD/B-НС16-120	P2770629	16	38	44.5	120	34	42	M12×1.0	4.40
	BT50AD/B-НС16-150	P2770630	16	38	44.5	150	34	42	M12×1.0	5.00
	BT50AD/B-НС18-90	P2770631	18	40	44.5	90	34	42	M12×1.0	4.00
	BT50AD/B-НС18-120	P2770632	18	40	44.5	120	34	42	M12×1.0	4.40
BT50AD/B-НС18-150	P2770633	18	40	44.5	150	34	42	M12×1.0	5.00	
BT50AD/B-НС20-90	P2770634	20	42	44.5	90	34	42	M16×1.0	4.00	
BT50AD/B-НС20-120	P2770635	20	42	44.5	120	34	42	M16×1.0	4.40	
BT50AD/B-НС20-150	P2770636	20	42	44.5	150	34	42	M16×1.0	5.00	
BT50AD/B-НС25-105	P2770637	25	57	63	105	52	48	M16×1.0	4.40	
BT50AD/B-НС25-150	P2770638	25	57	63	150	97	48	M16×1.0	5.60	
BT50AD/B-НС32-115	P2770639	32	64	75	115	62	55	M16×1.0	4.70	
BT50AD/B-НС32-150	P2770640	32	64	75	150	97	55	M16×1.0	6.00	

► Доступны изделия с конусом CAT (ANSI B5.50) и с дюймовой системой измерения.

ГИДРАВЛИЧЕСКИЕ ПАТРОНЫ (УЛЬТРА-КОРОТКИЕ) **NEW**

НС

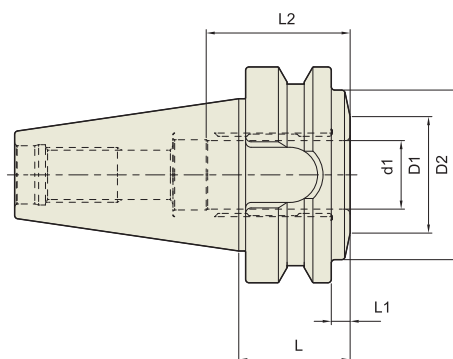

■ JIS B6339/MAS 403-BT

JIS B6339 -BT	Taper Accuracy AT3	G Value 2.5	RPM 25,000	Run-Out (at 3D) ≤3Um	Coolant System AD
------------------	--------------------------	----------------	---------------	----------------------------	-------------------------

Unit : mm

КОНУС No.	МОДЕЛЬ	Артикул	d1	D1	D2	L	L1	L2	G	ВЕС (Kg)
40	BT40-НС20-32.5	P2770642	20	34	49.5	32.5	5.5	42	-	

► Доступны изделия с конусом CAT (ANSI B5.50) и с дюймовой системой измерения.

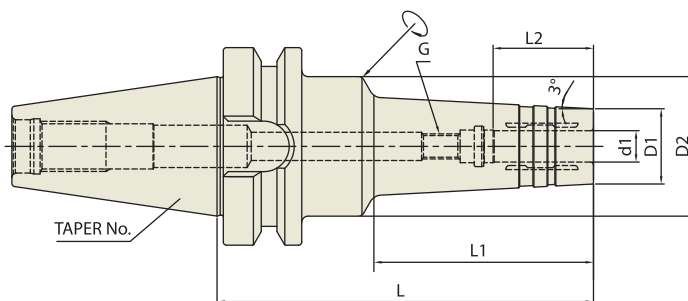

CBT (BT ДВОЙНОЙ КОНТАКТ)

CBT	Taper Accuracy AT3	G Value 2.5	RPM 25,000	Run-Out (at 3D) ≤3Um	Coolant System AD
-----	-----------------------	----------------	---------------	-------------------------	----------------------

Unit : mm

КОНУС No.	МОДЕЛЬ	АРТИКУЛ	d1	D1	D2	L	L1	L2	G	BEС (Kg)
40	CBT40-HMC6-120	P2770921	6	20	44.5	120	70	27	M5×0.8	1.40
	CBT40-HMC6-150	P2770922	6	20	44.5	150	100	27	M5×0.8	1.65
	CBT40-HMC8-120	P2770923	8	22	44.5	120	70	27	M6×1.0	1.40
	CBT40-HMC8-150	P2770924	8	22	44.5	150	100	27	M6×1.0	1.65
	CBT40-HMC10-120	P2770925	10	24	44.5	120	70	32	M8×1.0	1.40
	CBT40-HMC10-150	P2770926	10	24	44.5	150	100	32	M8×1.0	1.65
	CBT40-HMC12-120	P2770927	12	25	44.5	120	70	37	M10×1.0	1.40
	CBT40-HMC12-150	P2770928	12	25	44.5	150	100	37	M10×1.0	1.65
	CBT40-HMC16-120	P2770929	16	32	44.5	120	70	42	M12×1.0	1.45
	CBT40-HMC16-150	P2770930	16	32	44.5	150	100	42	M12×1.0	1.70
	CBT40-HMC20-120	P2770931	20	34	43.8	120	93	42	M16×1.0	1.50
	CBT40-HMC20-150	P2770932	20	34	46.9	150	123	42	M16×1.0	1.80
50	CBT50-HMC6-150	P2770933	6	20	50	150	90	27	M5×0.8	4.70
	CBT50-HMC8-150	P2770934	8	22	50	150	90	27	M6×1.0	4.70
	CBT50-HMC10-150	P2770935	10	24	50	150	90	32	M8×1.0	4.70
	CBT50-HMC12-150	P2770936	12	25	50	150	90	37	M10×1.0	4.70
	CBT50-HMC16-150	P2770937	16	32	50	150	90	42	M12×1.0	4.90
	CBT50-HMC20-150	P2770938	20	34	50	150	90	42	M16×1.0	5.00

ГИДРАВЛИЧЕСКИЕ ПАТРОНЫ (ТОНКИЕ)

HMC

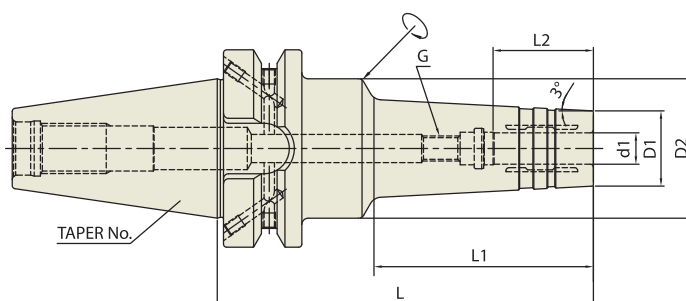

JIS B6339 - BT	Taper Accuracy AT3	G Value 2.5	RPM 25,000	Run-Out (at 3D) ≤3Um	Coolant System AD/B
-----------------------	------------------------------	-----------------------	----------------------	--------------------------------	-------------------------------

JIS B6339/MAS 403-BT

Unit : mm

КОНУС No.	МОДЕЛЬ	Артикул	d1	D1	D2	L	L1	L2	G	БЕС (Kg)
40	BT40AD/B-HMC6-120	P2770903	6	20	44.5	120	70	27	M5×0.8	1.40
	BT40AD/B-HMC6-150	P2770904	6	20	44.5	150	100	27	M5×0.8	1.65
	BT40AD/B-HMC8-120	P2770905	8	22	44.5	120	70	27	M6×1.0	1.40
	BT40AD/B-HMC8-150	P2770906	8	22	44.5	150	100	27	M6×1.0	1.65
	BT40AD/B-HMC10-120	P2770907	10	24	44.5	120	70	32	M8×1.0	1.40
	BT40AD/B-HMC10-150	P2770908	10	24	44.5	150	100	32	M8×1.0	1.65
	BT40AD/B-HMC12-120	P2770901	12	25	44.5	120	70	37	M10×1.0	1.40
	BT40AD/B-HMC12-150	P2770909	12	25	44.5	150	100	37	M10×1.0	1.65
	BT40AD/B-HMC16-120	P2770910	16	32	44.5	120	70	42	M12×1.0	1.45
	BT40AD/B-HMC16-150	P2770911	16	32	44.5	150	100	42	M12×1.0	1.70
50	BT40AD/B-HMC20-120	P2770902	20	34	43.8	120	93	42	M16×1.0	1.50
	BT40AD/B-HMC20-150	P2770912	20	34	46.9	150	123	42	M16×1.0	1.80
	BT50AD/B-HMC6-150	P2770913	6	20	50	150	90	27	M5×0.8	4.70
	BT50AD/B-HMC8-150	P2770914	8	22	50	150	90	27	M6×1.0	4.70
	BT50AD/B-HMC10-150	P2770915	10	24	50	150	90	32	M8×1.0	4.70
	BT50AD/B-HMC12-150	P2770916	12	25	50	150	90	37	M10×1.0	4.70
	BT50AD/B-HMC16-150	P2770917	16	32	50	150	90	42	M12×1.0	4.90
	BT50AD/B-HMC20-150	P2770918	20	34	50	150	90	42	M16×1.0	5.00

► Доступны изделия с конусом CAT (ANSI B5.50) и с дюймовой системой измерения.

ГИДРАВЛИЧЕСКИЕ ПАТРОНЫ

ГИДРАВЛИЧЕСКИЕ ПАТРОНЫ (Для шлифовального станка)

НС

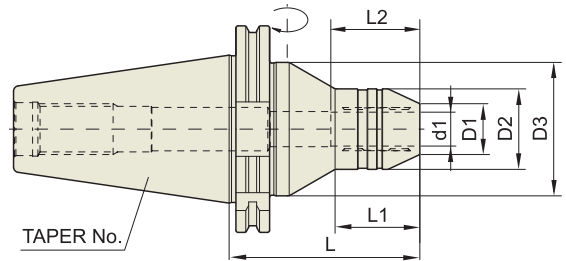

DIN 69871-SK	Taper Accuracy AT3	Run-Out (at 3D) ≤3Um	Coolant System AD
---------------------	------------------------------	--------------------------------	-----------------------------

■ DIN 69871-SK

Unit : mm

КОНУС No.	МОДЕЛЬ	АРТИКУЛ	d1	D1	D2	D3	L	L1	L2	БЕС (Kg)
50	SK50-HC6G-90	P2770951	6	14	30	63	90	30	27	3.00
	SK50-HC8G-90	P2770952	8	16	30	63	90	30	27	3.00
	SK50-HC10G-90	P2770953	10	18	30	63	90	30	32	3.00
	SK50-HC12G-90	P2770954	12	21	33	63	90	35	37	3.05
	SK50-HC14G-90	P2770955	14	22	35	63	90	35	37	3.10
	SK50-HC16G-90	P2770956	16	24	38	63	90	40	42	3.10
	SK50-HC18G-90	P2770957	18	26	40	63	90	40	42	3.10
	SK50-HC20G-110	P2770958	20	29	42	63	110	40	42	3.30
	SK50-HC25G-110	P2770959	25	34	50	70	110	45	48	3.60
SK50-HC32G-110	P2770960	32	42	56	80	110	50	55	4.20	

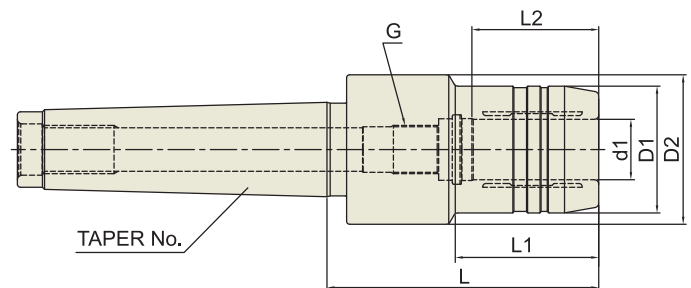

■ DIN 228-MTB

Unit : mm

КОНУС No.	МОДЕЛЬ	АРТИКУЛ	d1	D1	D2	L	L1	L2	G	БЕС (Kg)
4	MTB4-HC20-90	P2770961	20	42	49.5	90	47.5	42	M16×1.0	1.30
	MTB4-HC32-90	P2770962	32	72	72	90	-	55	-	1.40
5	MTB5-HC20-90	P2770963	20	42	49.5	90	47.5	42	M16×1.0	2.20
	MTB5-HC32-90	P2770964	32	72	72	90	-	55	-	2.40

НАБОР ГИДРАВЛИЧЕСКИХ ПАТРОНОВ **NEW**

HCS



МОДЕЛЬ	ПАТРОН	Артикул	REDUCTION SLEEVE	WRENCH
HCSS40-20	SK40AD/B-HC20P-64.5	P2770971	HK20-6.8.10.12.16 (5pcs)	φ5mm
HCSB40-20	BT40AD/B-HC20P-72.5	P2770972	HK20-6.8.10.12.16 (5pcs)	φ5mm
HCSH40-20	HSK63A-HC20P-80	P2770973	HK20-6.8.10.12.16 (5pcs)	φ5mm

ЦАНГИ ДЛЯ ГИДРАВЛИЧЕСКИХ ПАТРОНОВ

НК

(ПЕРЕХОДНЫЕ ВТУЛКИ: РАЗОМКНУТОГО ТИПА)

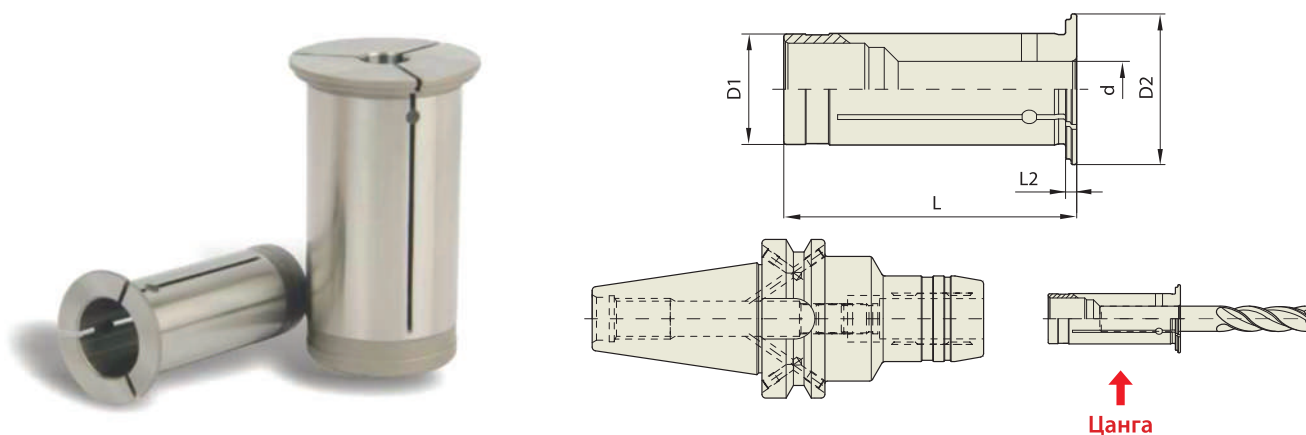

Unit : mm

МОДЕЛЬ	АРТИКУЛ	d	D1	D2	L	L2	
НК12	3	P2569022	3	12	19	47	2
	4	P2569023	4	12	19	47	2
	5	P2569024	5	12	19	47	2
	6	P2569025	6	12	19	47	2
	7	P2771001	7	12	19	47	2
	8	P2569026	8	12	19	47	2
НК20	3	P2569001	3	20	27	52.5	2
	4	P2569002	4	20	27	52.5	2
	5	P2569003	5	20	27	52.5	2
	6	P2569004	6	20	27	52.5	2
	7	P2771002	7	20	27	52.5	2
	8	P2569005	8	20	27	52.5	2
	9	P2771003	9	20	27	52.5	2
	10	P2569006	10	20	27	52.5	2
	11	P2771004	11	20	27	52.5	2
	12	P2569007	12	20	27	52.5	2
НК32	6	P2569010	6	32	39	63.5	3
	8	P2569011	8	32	39	63.5	3
	10	P2569012	10	32	39	63.5	3
	12	P2569013	12	32	39	63.5	3
	14	P2569014	14	32	39	63.5	3
	16	P2569015	16	32	39	63.5	3
	18	P2569016	18	32	39	63.5	3
	20	P2569017	20	32	39	63.5	3
25	P2569018	25	32	39	63.5	3	

ОСОБЕННОСТИ

Переходные втулки разделены на три равные части посредством высокоточной электроэрозионной обработки, что гарантирует высокую точность внутреннего диаметра.

МЕТОД ЗАЖИМА

Сначала установить режущий инструмент во втулку, а затем вставить втулку с инструментом в гидравлический патрон.

ЦАНГИ ДЛЯ ГИДРАВЛИЧЕСКИХ ПАТРОНОВ

HS

(ПЕРЕХОДНЫЕ ВТУЛКИ: ЗАМКНУТОГО ТИПА)

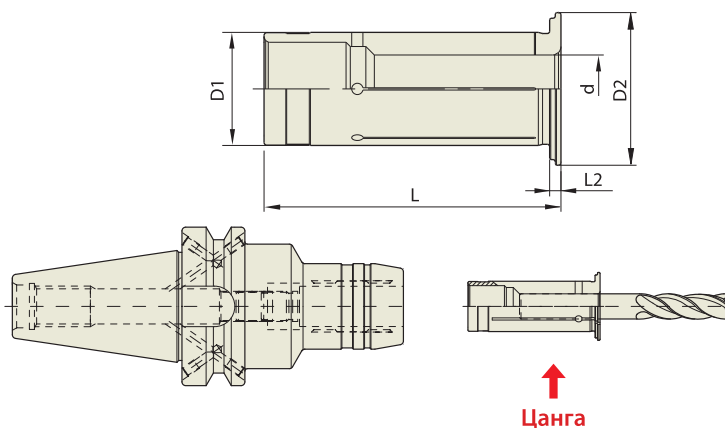

Unit : mm

МОДЕЛЬ	АРТИКУЛ	d	D1	D2	L	L2	
HS12	3	P2771101	3	12	19	47	2
	4	P2771102	4	12	19	47	2
	5	P2771103	5	12	19	47	2
	6	P2771104	6	12	19	47	2
	7	P2771105	7	12	19	47	2
	8	P2771106	8	12	19	47	2
HS20	3	P2771107	3	20	27	52.5	2
	4	P2771108	4	20	27	52.5	2
	5	P2771109	5	20	27	52.5	2
	6	P2771110	6	20	27	52.5	2
	7	P2771111	7	20	27	52.5	2
	8	P2771112	8	20	27	52.5	2
	9	P2771113	9	20	27	52.5	2
	10	P2771114	10	20	27	52.5	2
	11	P2771115	11	20	27	52.5	2
	12	P2771116	12	20	27	52.5	2
	13	P2771117	13	20	27	52.5	2
HS32	6	P2771121	6	32	39	63.5	3
	8	P2771122	8	32	39	63.5	3
	10	P2771123	10	32	39	63.5	3
	12	P2771124	12	32	39	63.5	3
	14	P2771125	14	32	39	63.5	3
	16	P2771126	16	32	39	63.5	3
	18	P2771127	18	32	39	63.5	3
	20	P2771128	20	32	39	63.5	3
	25	P2771129	25	32	39	63.5	3

ОСОБЕННОСТИ

Переходные втулки разделены посредством высокоточной электроэрозионной обработки, что гарантирует высокую точность внутреннего диаметра

МЕТОД ЗАЖИМА

Сначала установить режущий инструмент во втулку, а затем вставить втулку с инструментом в гидравлический патрон.

ЦАНГИ ДЛЯ ГИДРАВЛИЧЕСКИХ ПАТРОНОВ

HF

(ПЕРЕХОДНЫЕ ВТУЛКИ: С ПОДАЧЕЙ СОЖ)

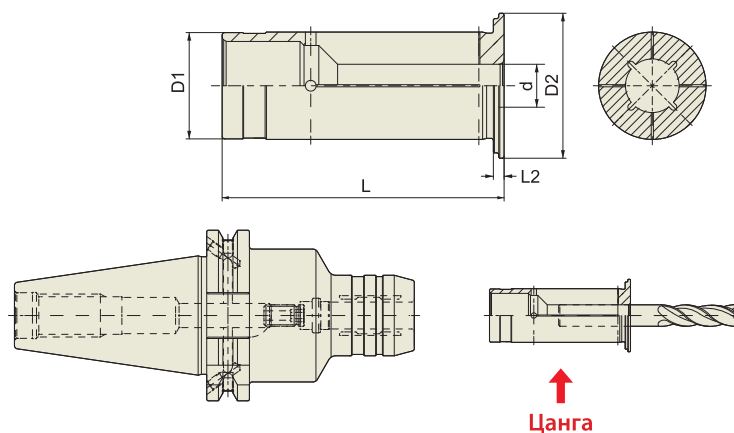

Unit : mm

МОДЕЛЬ	АРТИКУЛ	d	D1	D2	L	L2	
HF12	3	P2771201	3	12	19	47	2
	4	P2771202	4	12	19	47	2
	5	P2771203	5	12	19	47	2
	6	P2771204	6	12	19	47	2
	7	P2771205	7	12	19	47	2
	8	P2771206	8	12	19	47	2
HF20	3	P2771207	3	20	27	52.5	2
	4	P2771208	4	20	27	52.5	2
	5	P2771209	5	20	27	52.5	2
	6	P2771210	6	20	27	52.5	2
	7	P2771211	7	20	27	52.5	2
	8	P2771212	8	20	27	52.5	2
	9	P2771213	9	20	27	52.5	2
	10	P2771214	10	20	27	52.5	2
	11	P2771215	11	20	27	52.5	2
	12	P2771216	12	20	27	52.5	2
HF32	13	P2771217	13	20	27	52.5	2
	14	P2771218	14	20	27	52.5	2
	15	P2771219	15	20	27	52.5	2
	16	P2771220	16	20	27	52.5	2
	6	P2771221	6	32	39	63.5	3
	8	P2771222	8	32	39	63.5	3
	10	P2771223	10	32	39	63.5	3
	12	P2771224	12	32	39	63.5	3
	14	P2771225	14	32	39	63.5	3
	16	P2771226	16	32	39	63.5	3
	18	P2771227	18	32	39	63.5	3
	20	P2771228	20	32	39	63.5	3
	25	P2771229	25	32	39	63.5	3

ОСОБЕННОСТИ

Переходные втулки с возможностью внутренней подачи СОЖ.

МЕТОД ЗАЖИМА

Сначала установить режущий инструмент во втулку, а затем вставить втулку с инструментом в гидравлический патрон.

ЦАНГИ ДЛЯ ГИДРАВЛИЧЕСКИХ ПАТРОНОВ

HR

(ПЕРЕХОДНЫЕ ВТУЛКИ: ДЛЯ ПОДАЧИ СОЖ ПОД ВЫСОКИМ ДАВЛЕНИЕМ)

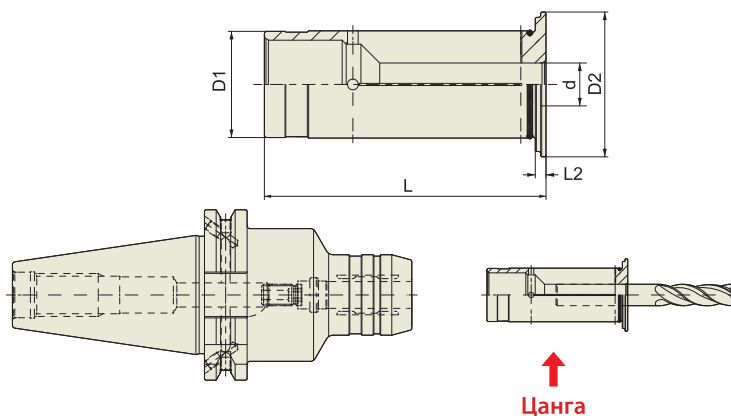

Unit : mm

МОДЕЛЬ	АРТИКУЛ	d	D1	D2	L	L2	
HR12	3	P2777601	3	12	19	47	2
	4	P2777602	4	12	19	47	2
	5	P2777603	5	12	19	47	2
	6	P2777604	6	12	19	47	2
	7	P2777605	7	12	19	47	2
	8	P2777606	8	12	19	47	2
HR20	3	P2777607	3	20	27	52.5	2
	4	P2777608	4	20	27	52.5	2
	5	P2777609	5	20	27	52.5	2
	6	P2777610	6	20	27	52.5	2
	7	P2777611	7	20	27	52.5	2
	8	P2777612	8	20	27	52.5	2
	9	P2777613	9	20	27	52.5	2
	10	P2777614	10	20	27	52.5	2
	11	P2777615	11	20	27	52.5	2
	12	P2777616	12	20	27	52.5	2
	13	P2777617	13	20	27	52.5	2
	14	P2777618	14	20	27	52.5	2
HR32	15	P2777619	15	20	27	52.5	2
	16	P2777620	16	20	27	52.5	2
	6	P2777621	6	32	39	63.5	3
	8	P2777622	8	32	39	63.5	3
	10	P2777623	10	32	39	63.5	3
	12	P2777624	12	32	39	63.5	3
	14	P2777625	14	32	39	63.5	3
	16	P2777626	16	32	39	63.5	3
	18	P2777627	18	32	39	63.5	3
20	P2777628	20	32	39	63.5	3	
25	P2777629	25	32	39	63.5	3	

ОСОБЕННОСТИ

Переходные втулки для подачи СОЖ под высоким давлением.

МЕТОД ЗАЖИМА

Сначала установить режущий инструмент во втулку, а затем вставить втулку с инструментом в гидравлический патрон.