

HYDRAULIC CLAMPING SYSTEMS

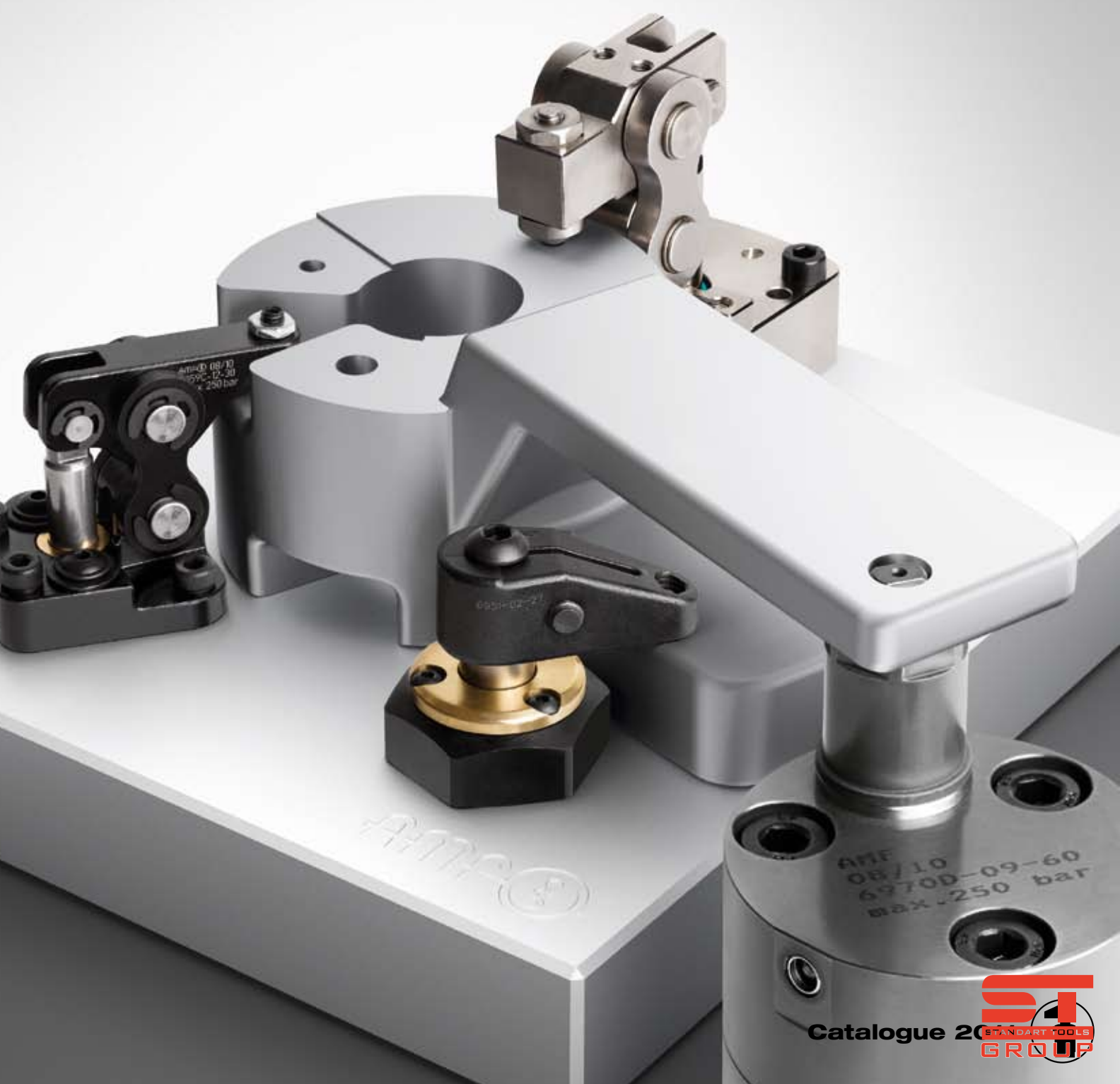

CLAMPING. SCREWING. LOCKING.



WE GENERATE EXCITEMENT.

Since its founding by Andreas Maier in 1890, our company has lived through many exciting times. Today we are the leading manufacturer in Europe, supplying over 5,000 different products from the fields of clamping, screwing and locking. With this extensive product range we can meet all of our customers' needs and requirements. But providing optimal quality means meeting the challenges at all levels: Expert consultation, modern team organisation, individual solutions (including special developments), flexibility in response to changing conditions, etc. And we ourselves find this so exciting that we look forward every day to shaping the market together with our employees and our customers – both now and in the future. That is something you can count on.

COMPANY HISTORY

- 1890** Company founded by Andreas Maier as a lock manufacturer.
- 1920** Production program extended to include spanners.
- 1928** Production-line assembly of „FELLBACH LOCKS“.
- 1951** With the introduction of clamping elements, AMF diversified into the fields of workpiece and tool clamping.
- 1965** Toggle clamps extend the AMF product range. AMF catalogues are now published in ten languages.
- 1975** Hydraulic clamping marks further specialisation.
- 1982** Clamping and fixture systems round off AMF's clamping expertise.
- 1996** Introduction of the AMF Team Organisation in all business sectors. Quality assurance certified to ISO 9001.
- 2001** Introduction of the AMF Service Guarantee for all products.
- 2004** Introduction of the ZPS zero-point clamping system.
- 2007** The Trec clamping system for automated welding and magnetic clamping technology extend the AMF product range.



MANAGING DIRECTORS

> Volker Göbel
 Johannes Maier
 Hans-Günther Maier



THE AMF SERVICE GUARANTEE

> Assuredly on the way to the top

5 Individual development

You cannot find the product you need? Talk to us; we will find the right solution for you – from a special version, right through to a completely new development.

4 Warranty

We believe in the high quality of our products. Complaints are dealt with quickly, unbureaucratically and generously – as far as possible, even well-beyond the guarantee period.

3 Certified quality

AMF stands for painstaking production in our own works. We have followed this tradition since 1890 – today, of course, with a modern quality assurance system to ISO 9001.

2 Short delivery times

From the AMF finished-product stores with over 5,000 articles, we can supply 98 % of orders from stock. And you can be sure that every stock article ordered is dispatched the same day.

1 Real technical advice

Many tasks and a multitude of solutions. From AMF Professional Products you can find the right way to solve your problem – fast and reliably – either at your local dealer or with the help of the specialist in our team. Just call us!

E Made in Germany

It goes without saying that our range of products is developed and manufactured by our team of employees in Germany.

PRESSURE GENERATORS

9 - 28



HOLLOW ROD AND BUILT-IN CYLINDERS

29 - 40



THREADED AND BLOCK CYLINDERS

41 - 64



**PUSH-PULL CYLINDERS
SWING CLAMPS**

65 - 96



**VERTICAL AND LINK CLAMPS
AND TOGGLE CLAMPS**

97 - 120



PULL-DOWN CLAMPING ELEMENTS

121 - 136



SUPPORT ELEMENTS, COMPENSATING CLAMPS

137 - 148



LOW-PRESSURE CLAMPING TECHNOLOGY

149 - 158



**VALVES, PRESSURE SWITCHES, FILTERS
ROTARY COUPLINGS AND ACCESSORIES**

159 - 204



TOOL CLAMPING FOR PRESSES

205 - 230





**Swing clamp,
threaded design**
No. 6952E, page 77



**Low pressure
Swing clamp**
No. 6941K, page 152



**Low pressure
Link clamp**
No. 6942K, page 156



Vertical clamp
No. 6958DU, page 106



Vertical clamp
No. 6958DT, page 107



**Link clamp,
integrated version**
No. 6959C, page 110



Vertical clamp
No. 6958AU / AT, page 100-103

Sequence valve

No. 6918-80, page 166



Hydraulic Compensating clamp

No. 6965, page 147



Pump unit

No. 6906, page 16, 20



Hydraulic pull-down spring clamp, eccentric

No. 6970D, page 126, 127



Filter with rectifier circuit

No. 6981G-xx-G1/4, page 193

Wedge clamp

No. 6946, page 228



RECOMMENDATIONS AND PARAMETERS OF OIL-HYDRAULIC DEVICES AND PLANTS.

GENERAL:

In this catalogue, parameters are published following the VDI Guidelines 3267 to 3284.

OIL RECOMMENDATION:

Oil temperature (°C)	designation to DIN 51 524	viscosity to DIN 51 519
0-40	HL, HLP or HLPD 22	ISO VG 22
10-50	HL, HLP or HLPD 32	ISO VG 32

CLAMPING ELEMENTS:

Pressure range:

Please indicate when ordering if continuous operating pressures below 80 bar are used. Such applications require different seal kits. See min. operating pressure specification on product page

Ambient temperature:

-10°C to +60°C

Thermal expansion:

If thermal expansion is prevented in a hydraulic system, the pressure rises by about 10 bar per 1 °C temperature increase. Such conditions require overpressure protection.

Seals:

- > O-rings made of NBR or PU
- > Supporting rings made of PTFE
- > Flange seals made of PTFE, NBR, PU or Cu
- > Glydring made of PTFE or PU
- > Scraper ring made of PU or NBR

At higher ambient temperatures, clamping elements have to be equipped with heat-resistant seals (Viton® or similar). These are available upon request.

Mounting position:

As desired, unless otherwise specified.

Piston radial force:

The piston radial force must never exceed 5% of the nominal cylinder force.

Stroke speed:

0.01 – 0.5 m/s (for swing clamps, always observe the specifications!).

Leakage rate:

Dynamic = up to 32 mm piston dia.:
 < 0.3 cm³ per 1000 double strokes and 10 mm stroke (HLP 22)
 from 40 mm piston dia.:
 < 0.6 cm³ per 1000 double strokes and 10 mm stroke (HLP 22)
 Static = no leakage rate

FOR YOUR SAFETY:

To avoid injuries, a maximum distance of 4 mm (in accordance with DIN 31001, part 1) between workpiece and clamping element must not be exceeded.

To ensure safe clamping, clamping elements must be positioned in such a way that a residual stroke remains in the clamping cylinder after clamping.

HOSE CONNECTIONS:

When using high-pressure hoses, the following must be observed:

- > maximum operating pressure
- > bending radius
- > tightening torque of cap nut
- > dynamic or static use
- > environmental influences
- > the date for the permissible duration of use

PIPES:

Seamless steel pipe, phosphatised and oiled, dia. 8x2 mm, in accordance with DIN 2391 C. Pipes must be kept as short as possible, especially when used with single-action cylinders. Pipe bends must be made to the largest possible radius.

CONNECTING THREADS:

Whitworth pipe thread, X-type threaded bore in accordance with DIN 3852, page 2. Seal by means of sealing edge. Do not use Teflon tape or additional sealing compound.

STATIC PRESSURE IN HYDRAULIC SYSTEM:

Cylinders, valves or lines and couplings create internal friction. An oil pressure of approx 2 bar is required to overcome this static pressure. For single-acting cylinders with return springs, the static pressure must be reduced by keeping the supply line as short as possible and using piston rods with the smallest possible mass.

For double-acting elements, static pressures increases when load is applied to the rod side. Parts of the relatively large oil volume on the piston side cannot drain quickly enough. Static pressure does usually not affect the clamping elements.

COMMISSIONING AND MAINTENANCE:

- > Use only clean hydraulic oil of the specified type.
- > Observe all instructions and information provided in mounting instructions before commissioning!
- > Vent the hydraulic system at low operating pressure at the highest point until the fluid is free of bubbles.

Hydraulic directional valves are very sensitive to soiling and contamination. Contamination and soiling of the pressure medium must be avoided. An oil change every six months is recommended. The oil level in the pressure generator must be checked regularly.

HYDRAULIC PARAMETERS, UNITS AND FORMULA SYMBOLS:

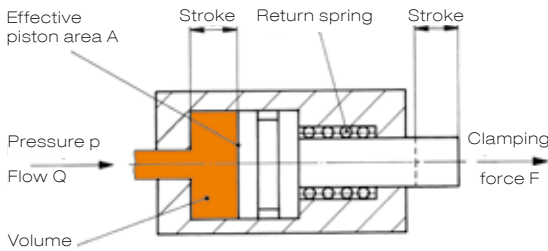

The units used in this catalogue for physical quantities are in accordance with DIN 1301.

Symbol	Unit	Description	Unit	Conversion
F	N	Force	Newton	1 N ≈ 0,1 kp 1 kN ≈ 100 kp
p	bar Pa	Pressure	bar Pascal	1 bar = 10 N/cm ² ≈ 1 atm. = 10 ⁵ N/m ² 1 Pa = 1 N/m ²
A	cm ²	Effective piston area	-	1 m ² = 10 ⁴ cm ²
V	cm ³	Volume	-	1 dm ³ = 1000 cm ³ = 1l (Liter)
t	s	Time	second	-
Q	$\frac{l}{min}$	Oil-flow rate	-	$1 \frac{l}{min} = 16,67 \frac{cm^3}{s}$

TECHNICAL EQUATIONS:

Clamping force F (N) = 10 x A (cm²) x p (bar)

Required operating pressure p (bar) = $\frac{0,1 \times F \text{ (N)}}{A \text{ (cm}^2\text{)}}$

Oil volume per cylinder V (cm³) = 0,1 x A (cm²) x stroke (mm)

Clamping time t (s) = $\frac{1 \times A \text{ (cm}^2\text{) x stroke (mm) x n (no's of cyl.)}{Q \text{ (l/min.)} \times 167}$

CLAMPING FORCE OF BOLTS:

For hydraulic clamping, the fatigue strength of the bolts is considered to obtain a high number of strokes. The testing force or yield strength must only be utilized for low numbers of strokes.

Clamping bolts					Hydraulic cylinders									
Thread	Pitch [mm]	Nominal cross-section As [mm ²]	Testing force for bolt grade 8.8 [kN]	Permissible load for continuous operation [kN]	Nominal cylinder size									
					2	5	8	12	20	32	50	70	125	
M 6	1,00	20,1	11,6	4,3										
M 8	1,25	36,6	21,2	8,0										
M 10	1,50	58,0	33,7	12,5										
M 12	1,75	84,3	48,9	18,3										
M 14	2,00	115,0	66,7	25,0										
M 16	2,00	157,0	91,0	34,0										
M 18	2,50	192,0	115,0	43,0										
M 20	2,50	245,0	147,0	55,0										
M 24	3,00	253,0	212,0	79,5										
M 27	3,00	459,0	275,0	103,0										
M 30	3,50	561,0	337,0	126,0										

NOMINAL CYLINDER SIZES:

The nominal cylinder sizes are intended to facilitate cylinder selection: These sizes correspond to the clamping force in kN, related to the maximum operating pressure in each case (usually 400 bar) and the effective piston area.

Nominal cylinder size	Piston dia. [mm]	Piston area [cm ²]	Clamping force F en kN				
			100 bar	250 bar	350 bar	400 bar	500 bar
2,0	8,0	0,5	0,50	1,25	1,75	2,0	2,5
2,4	9,0	0,7	0,68	1,70	2,40	-	-
4,4	12,5	1,3	1,25	3,10	4,40	-	-
5,0	12,0	1,1	1,10	2,80	3,80	4,4	5,5
5,9	14,7	1,7	1,70	4,20	5,90	-	-
6,6	15,5	1,9	1,90	4,70	6,60	-	-
8,0	16,0	2,0	2,00	5,00	7,00	8,0	10,0
10,1	19,0	2,9	2,88	7,20	10,1	-	-
12,0	20,0	3,1	3,00	7,50	10,9	12,0	15,0
14,0	22,0	4,0	4,00	10,0	14,0	-	-
17,5	25,0	5,0	5,00	12,7	17,5	-	-
17,8	25,0	5,1	5,08	12,7	17,8	-	-
20,0	25,0	4,9	5,00	12,5	17,2	20,0	24,5
32,0	32,0	8,0	8,00	20,0	28,0	32,0	40,0
39,9	38,0	11,4	11,4	28,5	39,9	-	-
50,0	40,0	12,5	12,5	31,0	43,8	50,0	62,5
63,0	45,0	15,9	15,9	39,1	55,6	63,6	79,5
70,0	48,0	18,0	18,0	45,0	63,0	72,0	90,0
78,0	50,0	19,6	19,6	49,0	68,6	78,4	98,0
94,0	55,0	23,7	23,7	59,2	83,0	94,8	118,5
125,0	63,0	31,1	31,1	78,0	108,8	124,0	155,5

Conversion factors:

Pressure:	MPa	bar	PSI
1 MPa	1	10	145,04
1 bar	0,1	1	14,504
1 PSI	0,00689	0,0689	1

MPa = Megapascal PSI = lb/sq. inch

Temperature:	K	°C	°F
K	1	°C x + 273,15	(°F - 459,67) x 5/9
°C	K - 273,15	1	(°F - 32) x 5/9
°F	K x 9/5 + 459,67	°C x 9/5 + 32	1

K = Kelvin °C = degree Celsius °F = degree Fahrenheit

Length:	mm	inch
1 inch	25,399	1
1 mm	1	0,0393

IMPORTANT INFORMATION ABOUT OUR INSTALLATION DRAWINGS.

ALL INSTALLATION DRAWINGS IN THIS CATALOGUE ARE IN FIRST-ANGLE PROJECTION (DIN)!

FIRST-ANGLE PROJECTION (DIN)

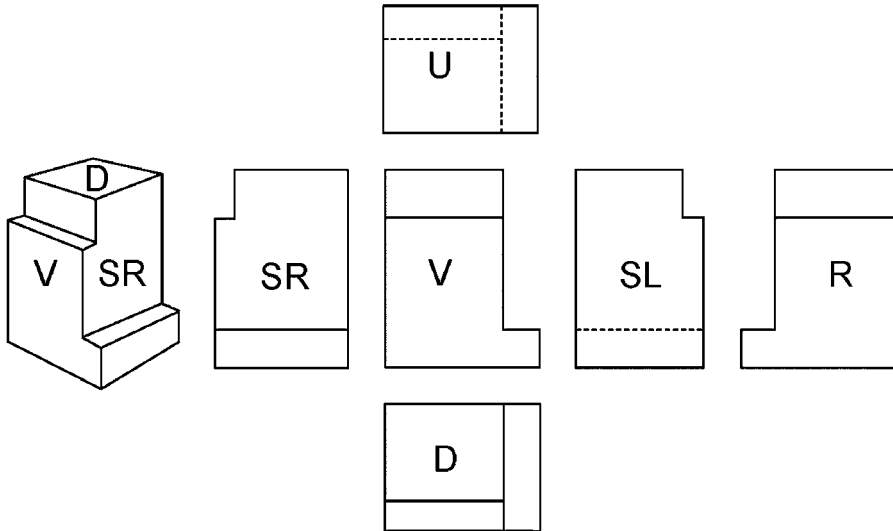

Location of other views in relation to front elevation, V:

D	Plan view	below V
SL	Side elevation from left	to the right of V
SR	Side elevation from right	to the left of V
U	Bottom view	above V
R	Rear view	to the left or right of V.

Symbol:

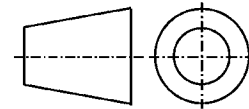

THIRD-ANGLE PROJECTION (ANSI / USA)

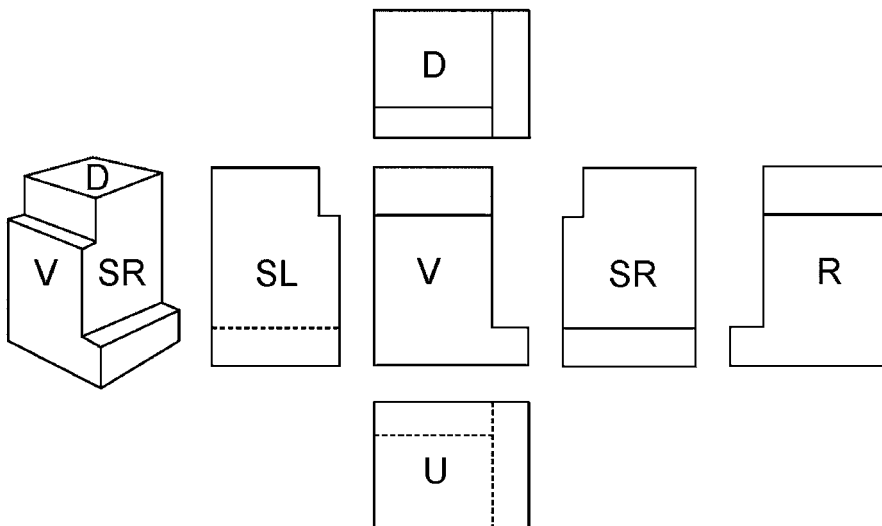

Location of other views in relation to front elevation, V:

D	Plan view	above V
SL	Side elevation from left	to the left of V
SR	Side elevation from right	to the right of V
U	Bottom view	below V
R	Rear view	to the left or right of V.

Symbol:

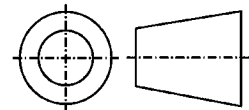

PRESSURE GENERATORS: THE OPTIMAL SOLUTION FOR ANY APPLICATION!

- > operating pressure up to 700 bar
- > easy to use
- > ready for connection
- > ready for operation
- > variety of options
- > compact design
- > single and double-acting variants
- > modular design of pump
- > various valve combinations
- > available with and without electric controller
- > external control optional
- > continuous pressure control by adjustment spindle
- > Valves in the de-energised condition in locked position

PRODUCT OVERVIEW:

Type	single-acting	double-acting	Clamping circuits (with control)	Output flow	Effective oil volume [l]
6901	√	-	1	2,1 cm ³ / Rotation	0,026
6902	√	-	1	11,25 / 2,47 cm ³ / stroke	1,0
6904	√	√	1	0,85 l/min.	2,1
6906	√	√	1 - 5	2,5 l/min.	5,0

PRODUCT EXAMPLES:

NO. 6902



- > Operating pressure 700 bar
- > 1 clamping circuit
- > no pressure adjustment

NO. 6904



- > Operating pressure 500 bar
- > 1 clamping circuit
- > automatic pressure-adjustment

NO. 6906



- > Operating pressure 400 bar
- > 1 to 6 clamping circuits
- > automatic pressure-adjustment

No. 6901 Screw Pump

block version and built-in version,
max. operating pressure 350 bar.



No. 6901-10



No. 6901-20

Order no.	Article no.	max. operating pressure [bar]	stroke volume per rev. [cm ³]	stroke volume total [cm ³]	max. torque at spindle [Nm]	Weight [g]
67819	6901-10	350	2,1	26	50	1524
67835	6901-20	350	2,1	26	50	689

Design:

Housing made of steel, hardened and blued. Threaded spindle hardened and blued. Screw pump no. 6901-20 is supplied with 2 grooved nuts.

Application:

The screw pump is particularly suitable to operate small clamping fixtures.

Note:

For an enclosed circuit the following has to be considered: The hydraulic clamping elements connected to the screw pump have to be hermetically tight. Due to possible leakage of the clamping cylinders during stroke movement and the compressibility of oil (1% at 140 bar), the stroke volume of the screw pump shall be used up to 70% only. The compressibility is being increased considerably by air content in the oil. Therefore the hydraulic system has to be carefully purged of air. An air bleed screw at the highest position is a necessity. After returning the spindle of the pump, oil must be refilled at this spot. No air pocket should arise in the hydraulic system, which cannot be purged. A precise pressure control is possible by a manometer only. An electric pressure switch enables a pressure monitoring too. A pressure limiting valve is not suitable. Operating the threaded spindle by a torque wrench is possible. However the pressure should also be checked by a gauge. For the built-in version the mounting torque has to be observed.

Clamping pressure in relation to torque

Torque [Nm]	Clamping pressure [bar]
13,5	70
27,0	140
34,0	205
40,5	275
47,5	350

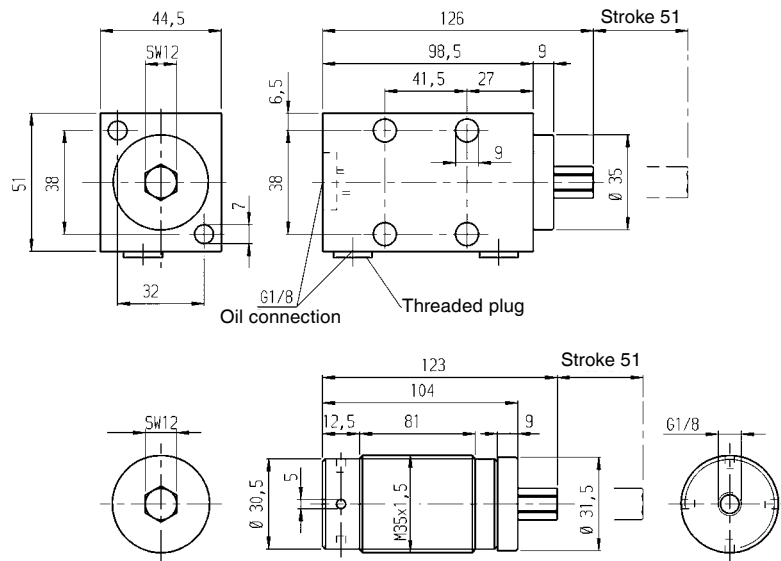

No. 6902

Hand Pump

max. operating pressure 700 bar.



Order no.	Article no.	max. operating pressure 1st stage [bar]	max. operating pressure 2nd stage [bar]	Displacement per stroke 1st stage [cm ³]	Displacement per stroke 2nd stage [cm ³]	Oil capacity usable [cm ³]	Max. hand lever force [N]	A	B	Weight [Kg]
61937	6902-7	50	700	20	1	300	350	320	275	6,0
61945	6902-8	50	700	20	2	1000	320	620	575	8,1

Design:

Light weight two-speed hand-pump. Small hand force required even by max. operating pressure. Pump housing out of mechan malleable cast iron. Oil reservoir made of alluminium. With pressure relief valve, factory set at max. pressure of 700 bar. Oil filling included.

Application:

Typical applications for the hand-pump are e.g. small clamping fixtures with irregular use, testing fixtures or for repair jobs. Please note, in case of a pressure drop the hand-pump is not capable of automatically maintaining system pressure.

Note:

Can be operated in horizontal position or vertical position with head facing downwards. Before putting in to operation open combined reservoir vent-and-relief cap. Care for proper air bleeding of connected hydraulic components. Special pumps for different fluids and pressure ratings are available upon request.

Hydraulic diagram

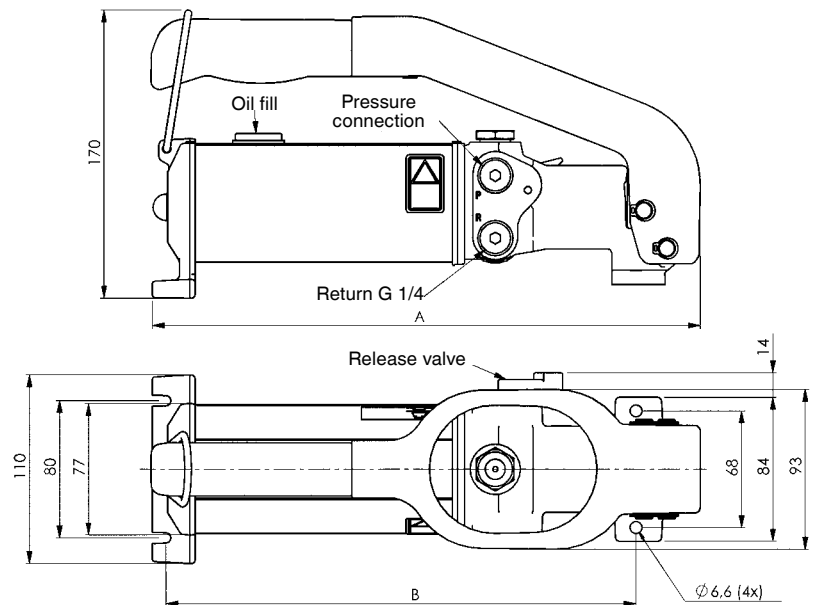
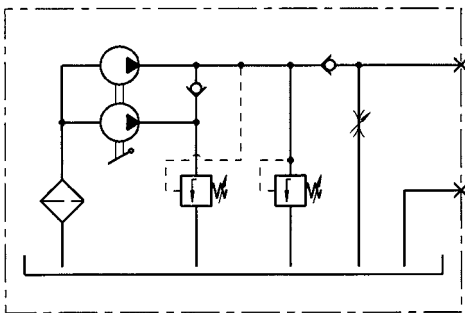

No. 6903 Hydraulic intensifier

Order no.	Article no.	Ratio i	max. operating pressure low pressure side [bar]	max. operating pressure high pressure side [bar]	max. oil flow rate low pressure side [l/min.]	max. oil flow rate high pressure side [l/min.]	Temp. [°C]	Weight [g]
452060	6903-20-15	1,5	200	300	8	1,0	-40 - +120	1000
320184	6903-20-20	2,0	200	400	12	2,0	-40 - +120	1000
275198	6903-20-32	3,2	200	640	15	2,5	-40 - +120	1000
320192	6903-20-40	4,0	200	800	14	2,0	-40 - +120	1000
291526	6903-20-50	5,0	160	800	14	1,6	-40 - +120	1000
320200	6903-20-66	6,6	120	800	13	1,3	-40 - +120	1000



Design:

For tube connection, all ports with thread G 1/4. Housing galvanised and chromate. Piston and valve seat made of steel.

Application:

Hydraulic intensifier are used to pressurise hydraulic clamping fixtures and assembly devices. The low pressure of the tooling machine's hydraulic system will be converted into a higher operating pressure according to the ratio. Input pressure and output pressure are proportional. The output pressure can be adjusted by the input pressure.

Features:

The most important functions are shown in the hydraulic circuit diagram (see below left). Oil is guided through directional valve CV to input IN and flows unimpeded through check valves KV1, KV2 and DV and into high pressure area H. In these conditions the pressure intensifier achieves a maximum flow rate with rapid forwards motion. Once input pressure IN is achieved in high-pressure area H, valves KV1, KV2 and DV close. The output pressure is built up by oscillating pump unit OP. The unit switches itself off automatically when the output pressure is achieved in high-pressure area H. In case of pressure loss in the high-pressure area due to consumption or loss of oil, pump unit OP starts automatically in order to maintain the output pressure. Pressure can be relieved from the high pressure area via the directly controlled valve DV.

Note:

The hydraulic oil must be filtered with mesh size not larger than nominally 10 µm, 19/16 according ISO 4406. If the intensifier will be used for applications where the oil supply is disengaged, a leakage free pilot controlled check valve should be installed between high pressure output H and the cylinder. Please consider the min. control pressure for releasing. The design of the intensifier allows a certain leakage between the ports IN and R. This has to be considered in uncoupled operations.

Hydraulic diagram:

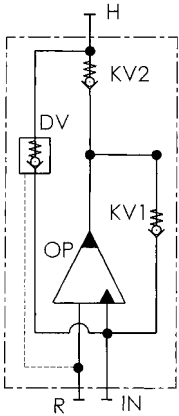

On request:

Manifold mounting and other sizes available on request.

Application examples:

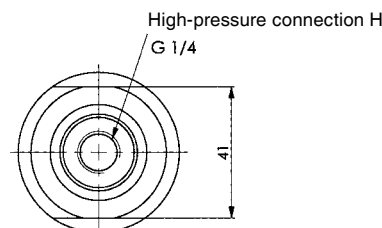
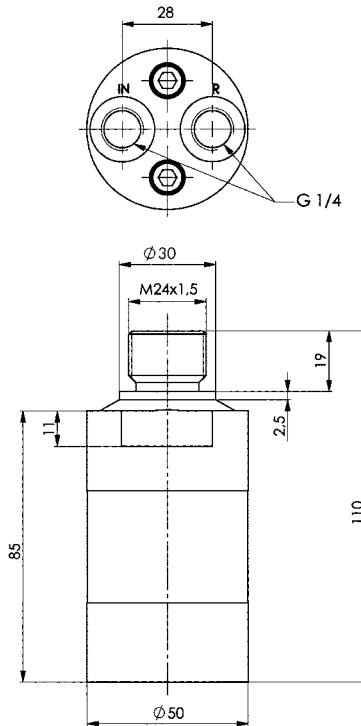
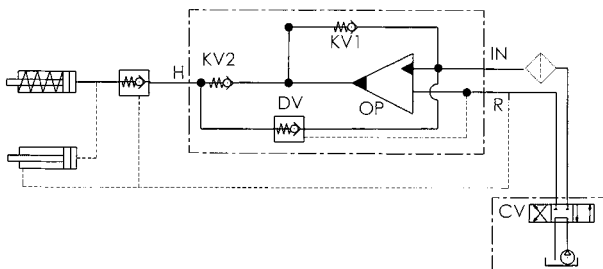
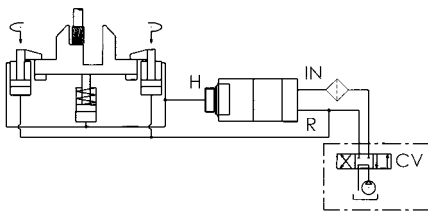

No. 6904-20

Air-Hydraulic Pump

max. operating pressure 500 bar.

Order no.	Article no.	Pneum. pressure min. [bar]	Pneum. pressure max. [bar]	Oil capacity usable horizontal [l]	Oil capacity usable vertical [l]	Flow rate max./min. [cm ³]	Weight [Kg]
69435	6904-20	2,8	10,0	2,1	1,5	1400	6,3

Design:

Compact, air operated hydraulic pump for single acting circuits. Robust plastic tank. The motor is protected against contamination by an air filter at air inlet and an internal oil filter. The pump is equipped with pressure relief valve and sound absorber.

Application:

The air-hydraulic pump can be used for small hydraulic clamping and assembly equipment. The air-hydraulic pump is designed for single acting cylinders.

Features:

The large air/oil intensification ratio allows for high hydraulic pressures even with small air pressure. Low weight allows for mobile application. The pump can be mounted horizontally or vertically. Applications in hazardous environment is possible.

Note:

Optionally, pumps with other operating pressures are available upon request. Please observe proper venting of the single acting system. All tolerances other than specified refer to DINISO 2768 mittel (medium).



Hydraulic diagram:

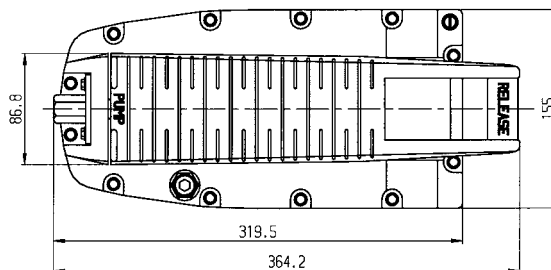
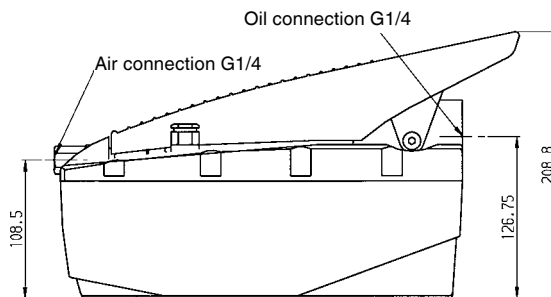
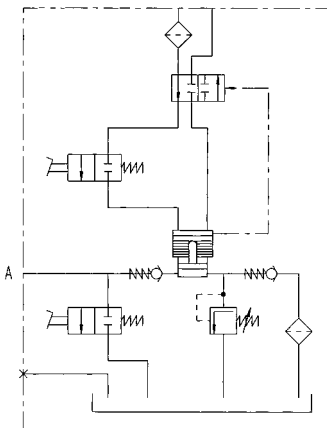

Pressure/flow diagram:

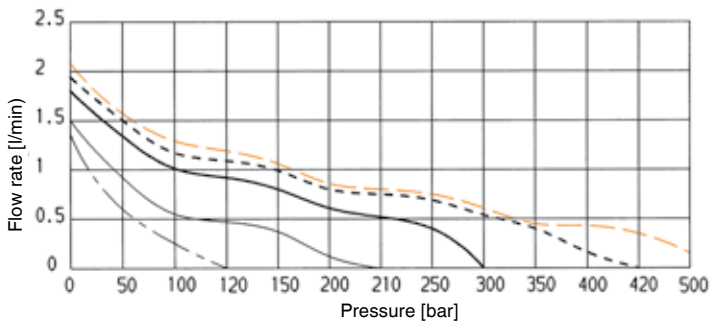

Air pressure

- = 2,8 bar
- = 4,1 bar
- = 5,6 bar
- = 6,9 bar
- = 8,3 bar

No. 6904-25

Air-Hydraulic Pump

max. operating pressure 500 bar.



Order no.	Article no.	Pneum. pressure min. [bar]	Pneum. pressure max. [bar]	Oil capacity usable horizontal [l]	Oil capacity usable vertical [l]	Flow rate max./min. [cm ³]	Weight [Kg]
69450	6904-25	2,8	10,0	2,1	1,5	1400	6,3

Design:

Compact, air operated hydraulic pump for single and double acting circuits. Robust plastic tank. The motor is protected against contamination by an air filter at air inlet and an internal oil filter. The pump is equipped with pressure relief valve and sound absorber.

Application:

The air-hydraulic pump can be used as drive element for small hydraulic and assembly equipment. Safety is guaranteed by automatic pressure compensation. The air-hydraulic pump is designed for the assembly of valves with connection diagram CETOP 03, i.e. with the option to control single or double acting cylinders. The changeover can be made manually, pneumatically or electrically.

Features:

The large air/oil intensification ratio allows for high hydraulic pressures even with small air pressure. Low weight allows for mobile application. The pump can be mounted horizontally or vertically. Applications in hazardous environment is possible.

Note:

Optionally, pumps with other operating pressures are available upon request. Please observe proper venting of the single acting system. All tolerances other than specified refer to DINISO 2768 mittel (medium).

Hydraulic diagram:

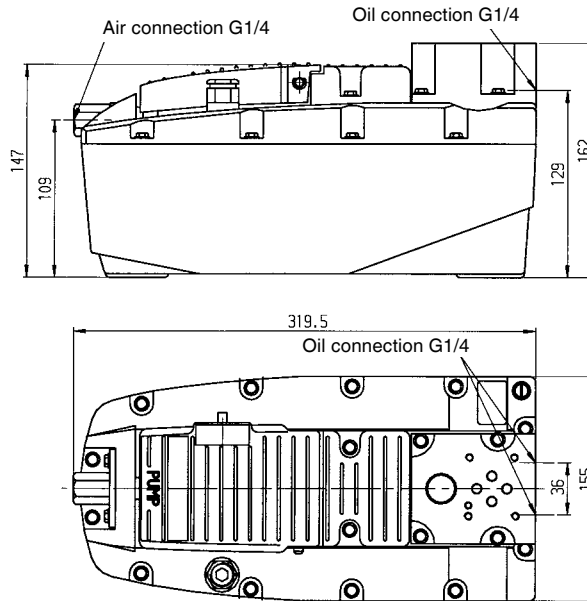
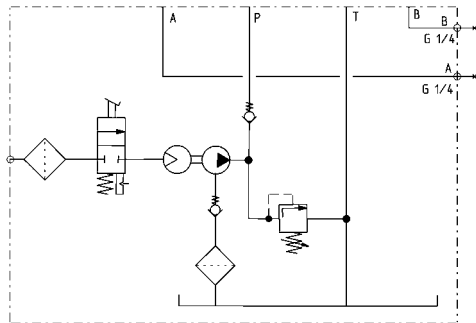

Pressure/flow diagram:

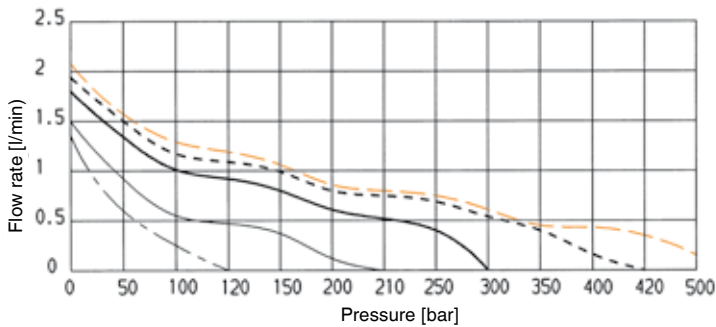

Air pressure

- = 2,8 bar
- = 4,1 bar
- = 5,6 bar
- - - = 6,9 bar
- - - = 8,3 bar

Subject to technical alterations.

No. 6904-50

Seat Valve 3/2

manually operated,
max. operating pressure 500 bar, min. operating pressure 10 bar.

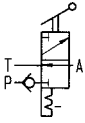

Order no.	Article no.	NG	Type	Nominal flow [l/min]	Weight [g]
271031	6904-50	6	Seat valve	12	444

Application:

For single acting cylinders. CETOP 3 adaptation.

No. 6904-52

Seat Valve 3/2

solenoid operated,
max. operating pressure 500 bar, min. operating pressure 10 bar.

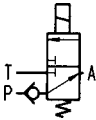

Order no.	Article no.	NG	Type	Nominal flow [l/min]	Weight [g]
259242	6904-52	6	Seat valve	12	740

Application:

For single acting cylinders. CETOP 3 adaptation.

No. 6904-54

Seat Valve 3/2

pneumatically operated,
max. operating pressure 500 bar, min. operating pressure 10 bar.

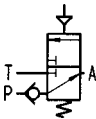

Order no.	Article no.	NG	Type	Nominal flow [l/min]	Weight [g]
267427	6904-54	6	Seat valve	12	459

Application:

For single acting cylinders. CETOP 3 adaptation.

No. 6904-59

Seat Valve 4/3

manually operated,
max. operating pressure 700 bar, min. operating pressure 10 bar.

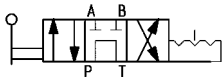

Order no.	Article no.	NG	Type	Nominal flow [l/min]	Weight [g]
326363	6904-59	6	Seat valve	30	380

Application:

For double acting cylinders. CETOP 3 adaptation.

No. 6911A-07-01

Seat valve 4/3

solenoid operated,
max. operating pressure 400 bar, min. operating pressure 10 bar.

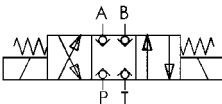

Order no.	Article no.	NG	Type	Nominal flow [l/min]	Weight [g]
322065	6911A-07-01	6	Seat valve	20	2356

Application:

For double acting cylinders. CETOP 3 adaptation.

Note:

Further information can be found under Accessories/Valves.

No. 6904-90

Air filter and pressure regulator



Order no.	Article no.	Air connection	Weight [g]
258236	6904-90	G 1/4	740

Application:

For Air-Hydraulic Pump No. 6904-20 or -25.

No. 6906 Pump unit

With pressure limiting valve and electronic pressure switch, single- and double-acting, max. operating pressure 400 bar.



Order no.	Article no.	Clamping circuits	Flow rate [l/min.]	Valve type	Matching control unit	Electronic control	Pressure switch	Weight [Kg]
325902	6906-61710	1	2,5	3/3	-	-	-	53
325910	6906-61711	1	2,5	3/3	6906B-2-1	√	-	61
325928	6906-61711-BZH	1	2,5	3/3	6906BZH-2	√	2	61
325936	6906-62710	2	2,5	3/3	-	-	-	56
325944	6906-62711	2	2,5	3/3	6906B-3-2	√	-	64
322214	6906-61610	1	2,5	4/3	-	-	-	53
325951	6906-61611	1	2,5	4/3	6906B-2-1	√	-	61
325969	6906-61611-BZH	1	2,5	4/3	6906BZH-2	√	2	61
322230	6906-62610	2	2,5	4/3	-	-	-	56
325977	6906-62611	2	2,5	4/3	6906B-3-2	√	-	64

Design:

Compact, pluggable pump unit, can be operated electrically and hydraulically. Complete with: pressure relief valve and pressure switch, solenoid valve, pressure gauge, floating switch with temperature monitoring, oil filling, electrical controller with main switch, control lamps and flange sockets. Electrical connection, complete with CEKON plug, pressure filter with filter mesh of 25µm.

Application:

These pump units are mainly used as drive and control elements for single- and double-acting clamping devices.

Operation type:

Control panel for one and two clamping circuits. Two-hand control panel for only one clamping circuit.

Features:

The radial piston pump is driven via an alternating current standard motor with the energy efficiency class IE3. The motor is protected against overload by a motor protection switch. Pressure setting and pressure monitoring are accomplished via a pressure limiting valve (DBV) and an electronic pressure switch (DS). The value set at the pressure limiting valve is stored with the Mode button on the pressure switch. This simultaneously sets the preprogrammed switch-off and switch-back point.

- High safety standard through the use of 3/3- and 4/3-way seat valves!
- No unwanted traversing movements. In the event of a loss of power or contact problems, the valve returns to the hermetically sealed centre position.
- Easy activation of external machine controllers (e.g. PLC).

The pump unit works in intermittent mode. In the event of a loss of pressure, the pump is subsequently automatically switched by the pressure switch. In the event of a lack of oil or an increase in oil temperature, the built-in floating switch with temperature monitoring switches the pump off and the fault lamp on the electrical controller lights up.

Note:

Ensure that the ventilation is working properly when connecting the elements. In the event of a loss of pressure, subsequent pumping must not exceed a maximum of 2 times per minute. The pump unit must not be allowed to run continuously.

Options:

Clamping circuits: For up to 5 clamping circuits, there is an electrical controller. For more than 5 clamping circuits, there is no electrical controller.

Valve combination: Pressure reduction and clamping pressure monitoring in certain clamping circuits. Pressure reduction for all subsequent clamping circuits. Pressure filter with filter mesh 10µm or 40 µm. Throttle valves for specified clamping circuits.

On request:

Directional valves with other function diagrams on request.
Three to five clamping circuits on request.

Hydraulic diagrams

Energizing both valve magnets creates a switching position that links all 4 or 3 connections to each other. A depressurised state is created that allows easy coupling.

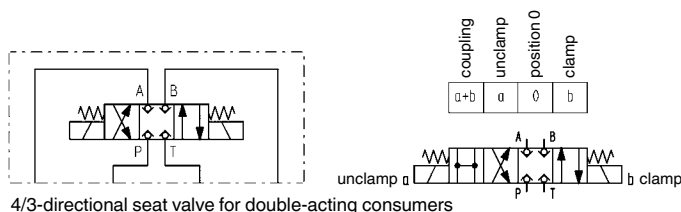
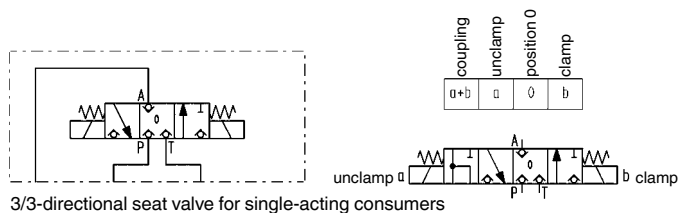

Subject to technical alterations.

Hydraulic diagrams with DBV and DS

1 Clamping circuit, double-acting

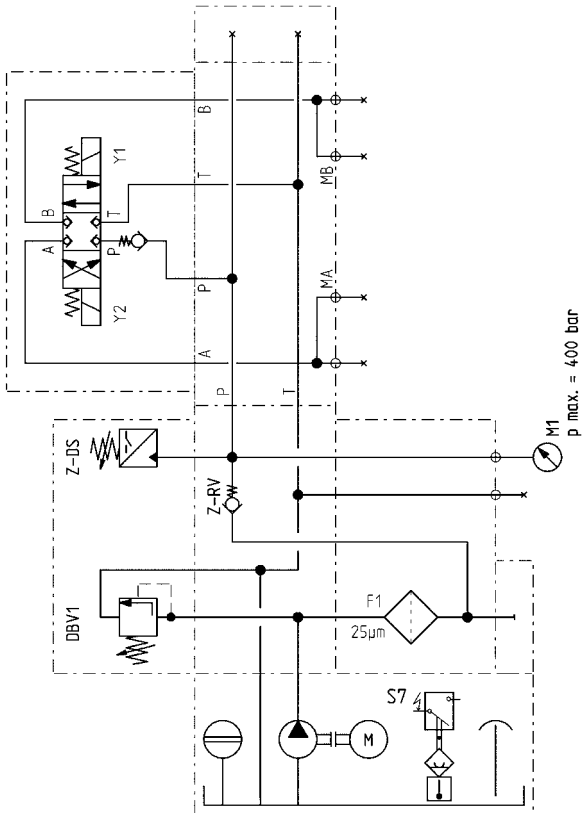

2 Clamping circuits, double-acting

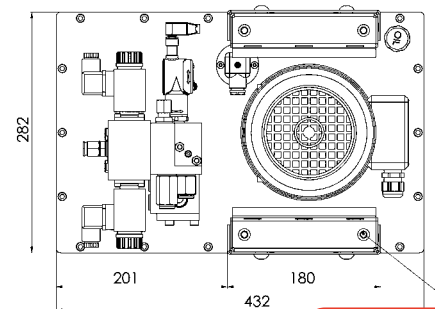
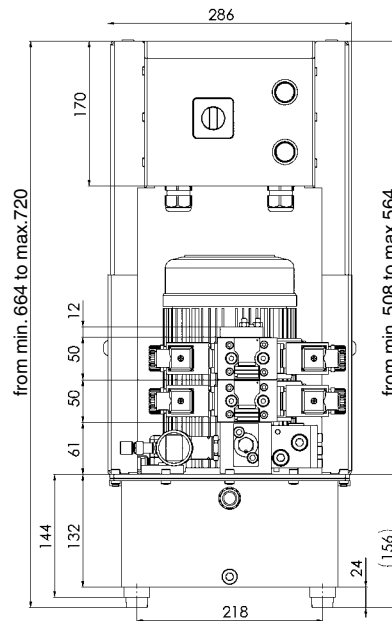
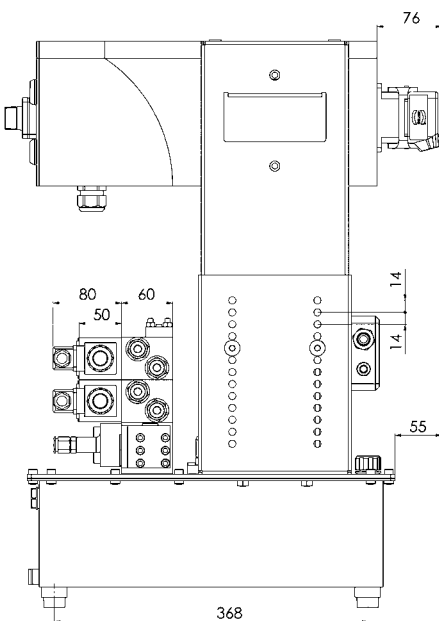
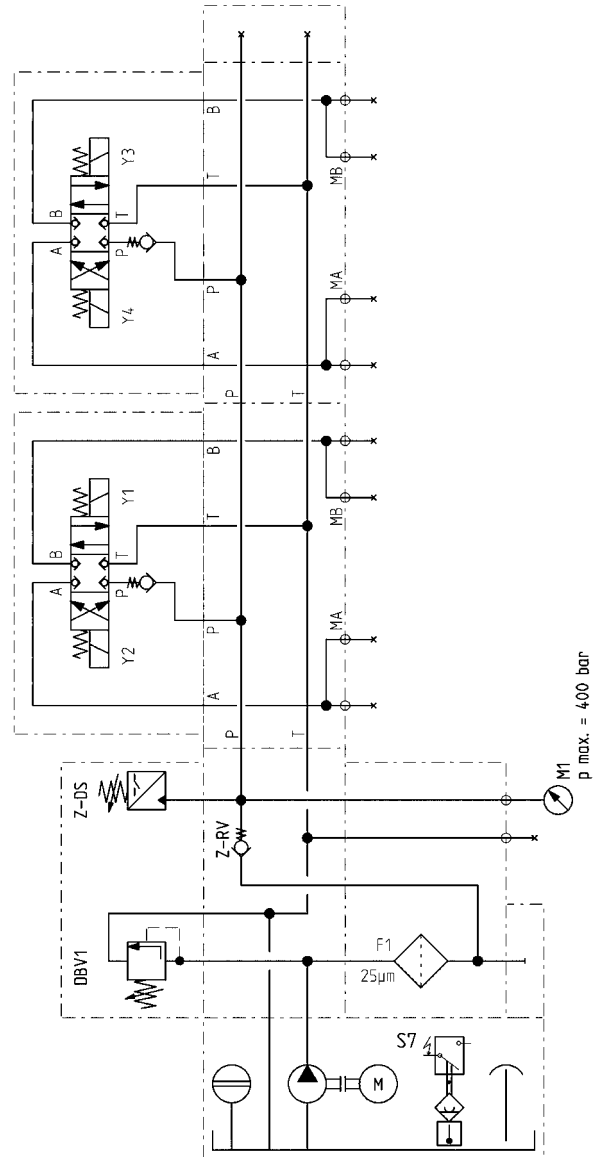

M8 thread for lifting devices

Subject to technical alterations.

STANDART TYPEN

No. 6906 pump unit, 1 and 2 clamping circuits

Hydraulic specifications:

Max. operating pressure	400 bar
Min. operating pressure	40 bar
Oil capacity, reservoir	10 litres
Oil capacity, usable	4 litres
Oil-flow rate	2,5 l/min.
Valve types	4/3 seat valve and 3/3 seat valve
No. of hydraulic circuits	1 oder 2
Hydraulic connection	pipe fitting G1/4
Noise level	max. 70 dB(A)
Ambient temp. range	-10° C to + 35° C
Position of use	upright
Pump design	radial-piston pump with 3 pistons
Load cycle	max. 500/h
Fluid	hydraulic oils HLP and HLPD according to DIN 51524 part 2
Oil recommendation	HLP 22 and HLPD 22 or HLP 32 and HLPD 32
Viscosity	ISO VG 22 and 32 DIN 51519

Electrical specifications:

Nominal voltage	400 V/50 Hz three-phase
Control voltage	24 V DC
Valve voltage	24 V DC
Motor speed	2900 1/min.
Direction of rotation	any
Motor rating	1,1 kW
Motor type	three-phase standard motor
Nominal current	3 A
Fuse, supply line	16 A slow-blow
Fuse, control circuit	2 A primary, 8 A secondary
Electrical connection	Ölflex 100; 5 × 1,5 mm ² 3 m with CEE connector 16 A 6 h
Protection class	IP 54
Duty cycle	max. 50 % intermittent operation

Wiring circuit of pump unit with 2 clamping circuits, remote control

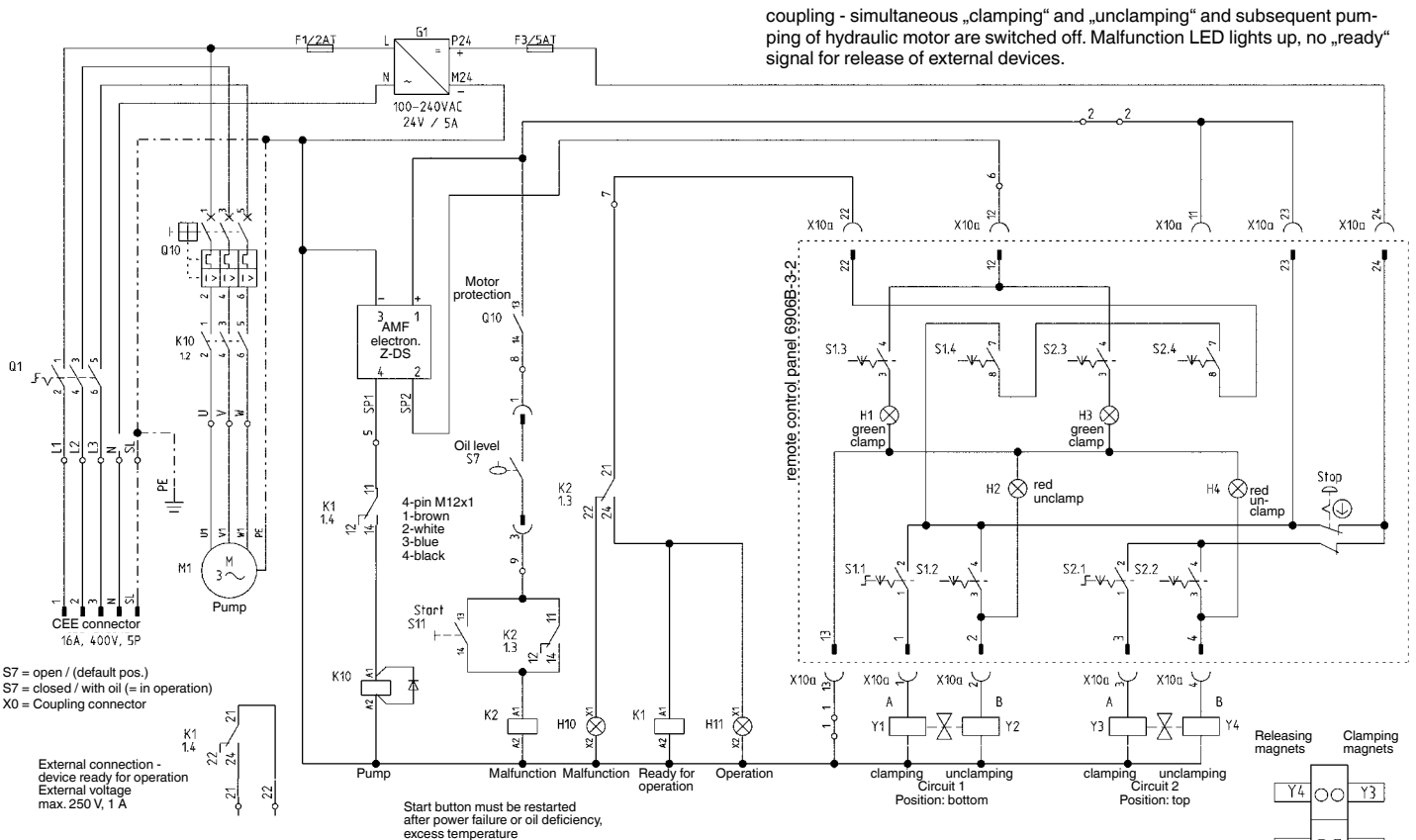

To increase safe handling of the clamped parts, the unit ready for operation and a clamping pressure query should be integrated with the processing machine.

FUTURE-COMPATIBLE AND ENVIRONMENTALLY CONSCIOUS

AMF PUMP UNITS ARE AHEAD OF THEIR TIME

FUTURE-COMPATIBLE THANKS TO ELECTRIC MOTORS WITH HIGHER ENERGY EFFICIENCY CLASSES

At the end of 2009, a new EU regulation was adopted that defined, among other things, new guidelines for the environmentally-friendly design of electric motors. The goal is to reduce energy consumption and thus also CO₂ emissions. On 16th June 2011 the first stage of the transition period will end and the amendment will enter into force; the second stage will follow in 2017.

Our electric motors already comply with these directives, and thus also comply with the energy efficiency classes that will be required in 2017.

This is attested by the „Pro Energy Efficiency Initiative“ seal.

The benefits at a glance:

- > energy-saving operation thanks to optimised energy-saving motor
- > greater efficiency
- > ecological operation of the pump units
- > future-compatible operation, compliant with the 2017 standard.



ENVIRONMENTALLY CONSCIOUS OPERATION WITH BIO OIL

Our new hydraulic pump units can be operated either with conventional mineral-based industrial oil, or with biodegradable industrial vegetable oil.

The advantages of bio oil:

- > energy savings of 20 - 30 %
- > lower noise level
- > longlife oil for longer oil change intervals
- > produced on the basis of renewable resources
- > highly biodegradable
- > not hazardous to waters
- > suitable for use in the food industry
- > approved by leading machine manufacturers

Please get in touch with us!



No. 6906 Pump unit

with pressure-control device,
single- and double-acting,
max. operating pressure 400 bar.



Order no.	Article no.	Clamping circuits	Flow rate [l/min.]	Valve type	Matching control unit	Electronic control	Pressure switch	Weight [Kg]
325985	6906-61720	1	2,5	3/3	-	-	-	53
325993	6906-61721	1	2,5	3/3	6906B-2-1	√	-	61
326009	6906-61721-BZH	1	2,5	3/3	6906BZH-2	√	2	61
326017	6906-62720	2	2,5	3/3	-	-	-	56
326025	6906-62721	2	2,5	3/3	6906B-3-2	√	-	64
324590	6906-61620	1	2,5	4/3	-	-	-	53
326033	6906-61621	1	2,5	4/3	6906BT-2-1	√	-	61
326041	6906-61621-BZH	1	2,5	4/3	6906BZH-2	√	2	61
324616	6906-62620	2	2,5	4/3	-	-	-	56
326058	6906-62621	2	2,5	4/3	6906B-3-2	√	-	64

Design:

Compact, pluggable pump unit, can be operated electrically and hydraulically. Complete with: pressure-control device, solenoid valve, pressure gauge, floating switch with temperature monitoring, oil filling, electrical controller with main switch, control lamps and flange sockets. Electrical connection, complete with CEKON plug, pressure filter with filter mesh of 25µm.

Application:

These pump units are mainly used as drive and control elements for single- and double-acting clamping devices.

Operation type:

Control panel for one and two clamping circuits. Two-hand control panel for only one clamping circuit.

Features:

The radial piston pump is driven via an alternating current standard motor with the energy efficiency class IE3. The motor is protected against overload by a motor protection switch. Pressure setting and pressure monitoring are made via a pressure control device.

- High safety standard through the use of 3/3- and 4/3-way seat valves!
- No unwanted traversing movements. In the event of a loss of power or contact problems, the valve returns to the hermetically sealed centre position.
- Easy activation of external machine controllers (e.g. PLC).

The pump unit works in intermittent mode. In the event of a loss of pressure, the pump is subsequently automatically switched by the pressure control device. In the event of a lack of oil or an increase in oil temperature, the built-in floating switch with temperature monitoring switches the pump off and the fault lamp on the electrical controller lights up.

Note:

Ensure that the ventilation is working properly when connecting the elements. In the event of a loss of pressure, subsequent pumping must not exceed a maximum of 2 times per minute. The pump unit must not be allowed to run continuously.

Options:

Clamping circuits: For up to 5 clamping circuits, there is an electrical controller. For more than 5 clamping circuits, there is no electrical controller.

Valve combination: Pressure reduction and clamping pressure monitoring in certain clamping circuits. Pressure reduction for all subsequent clamping circuits. Pressure filter with filter mesh 10µm or 40 µm. Throttle valves for specified clamping circuits.

On request:

Directional valves with other function diagrams on request.
Three to five clamping circuits on request.

Hydraulic diagrams

Energizing both valve magnets creates a switching position that links all 4 or 3 connections to each other. A depressurised state is created that allows easy coupling.

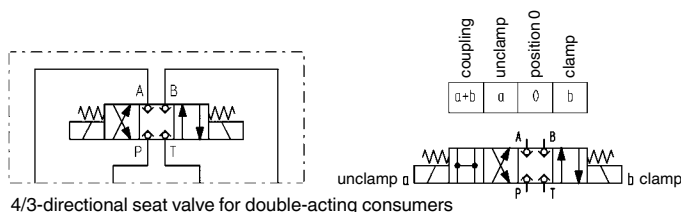
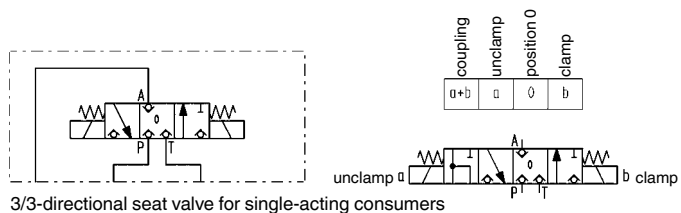

Subject to technical alterations.

Hydraulic diagrams with DSG

1 Clamping circuit, double-acting

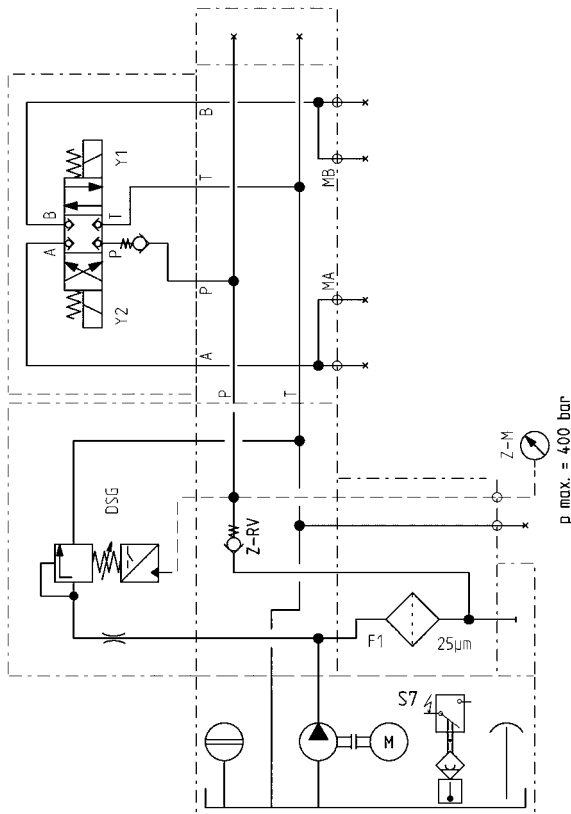

2 Clamping circuits, double-acting

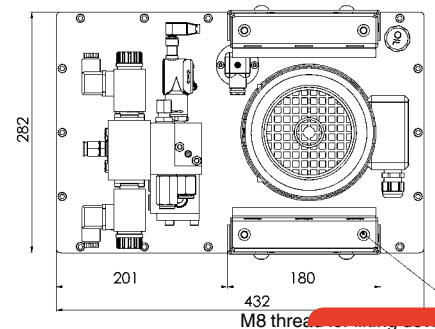
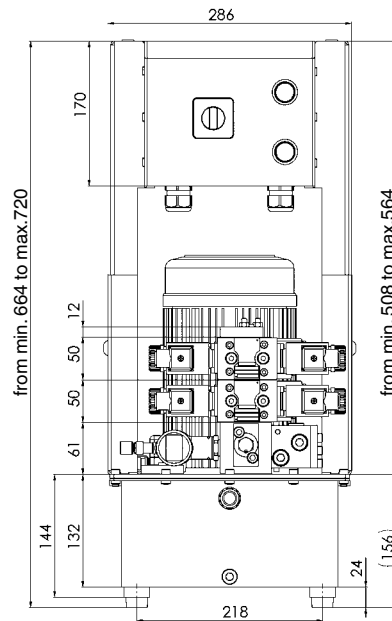
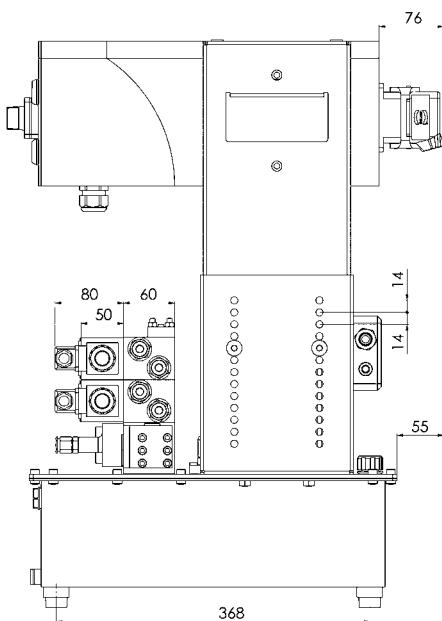
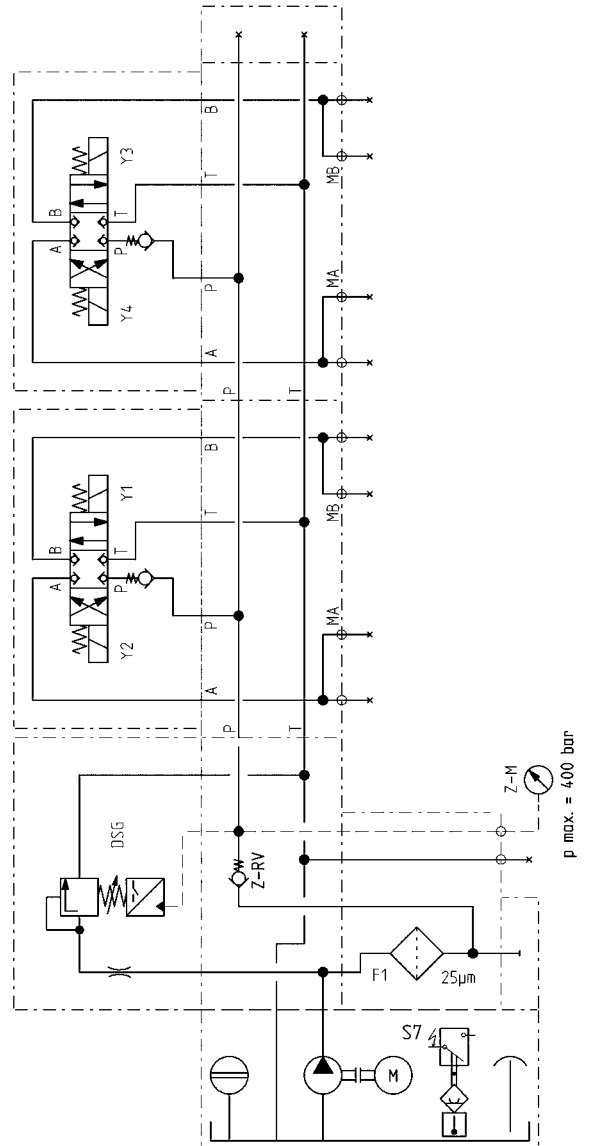

Subject to technical alterations.

No. 69061 pump unit, 1 and 2 clamping circuits

Hydraulic specifications:

Max. operating pressure	400 bar
Min. operating pressure	40 bar
Oil capacity, reservoir	10 litres
Oil capacity, usable	4 litres
Oil-flow rate	2,5 l/min.
Valve types	4/3 seat valve and 3/3 seat valve
No. of hydraulic circuits	1 or 2
Hydraulic connection	pipe fitting G1/4
Noise level	max. 70 dB(A)
Ambient temp. range	-10° C to + 35° C
Position of use	upright
Pump design	radial-piston pump with 3 pistons
Load cycle	max. 500/h
Fluid	hydraulic oils
	HLP and HLPD according to DIN 51524 part 2
Oil recommendation	HLP 22 and HLPD 22 or
	HLP 32 and HLPD 32
Viscosity	ISO VG 22 and 32 DIN 51519

Electrical specifications:

Nominal voltage	400 V/50 Hz three-phase
Control voltage	24 V DC
Valve voltage	24 V DC
Motor speed	2900 1/min.
Direction of rotation	any
Motor rating	1,1 kW
Motor type	three-phase standard motor
Nominal current	3 A
Fuse, supply line	16 A slow-blow
Fuse, control circuit	2 A primary, 8 A secondary
Electrical connection	Ölflex 100; 5×1,5 mm ² 3 m with CEE connector 16 A 6 h
Protection class	IP 54
Duty cycle	max. 50 % intermittent operation

Wiring circuit of pump unit with 2 clamping circuits, remote control

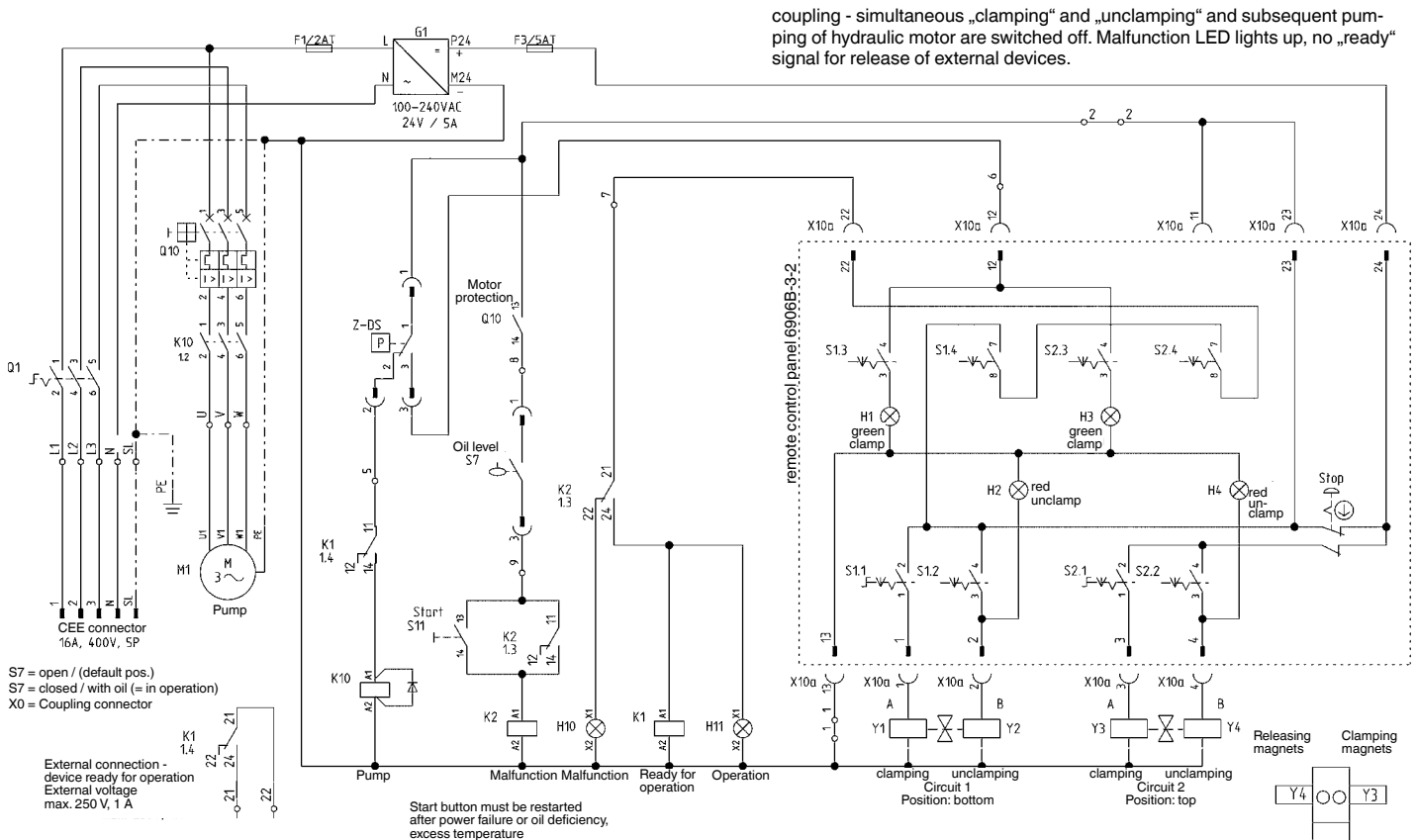

To increase safe handling of the clamped parts, the unit ready for operation and a clamping pressure query should be integrated with the processing machine.

MODULAR PUMP UNIT NO. 6906

OPTIONS:

Oil-tank volume: 10,0 litres, total
4.0 litres usable

Oil-flow rate: 2,5 l/min. or
5,0 l/min.

Clamping circuits: up to 5 clamping circuits including electrical control. For more than 5 clamping circuits without electrical control.

Further options:

- > Two-hand remote-control panel (only for pump units with 1 clamping circuit)
- > Pressure-control device for stepless pressure adjustment by a single spindle
- > Valve combinations with pressure-control and throttle valves

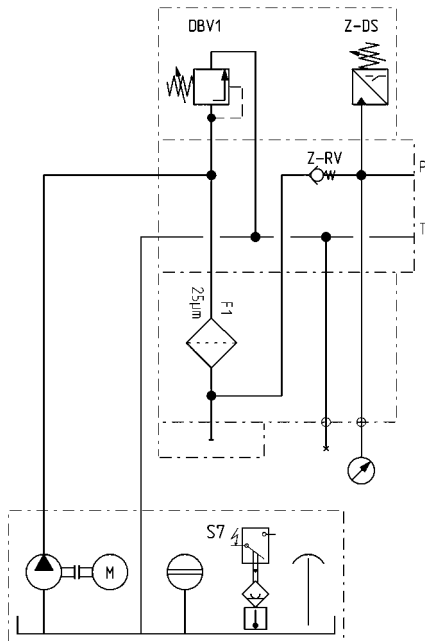

RKP 2,5 : Q = 2,5 l/min, n = 2900 U/min.
Tank volume: V = 10 l

BASE UNIT



... WITH VALVES



... WITH VALVES AND CONTROLLER



Spacer plates - pressure-control valve
Control function in P

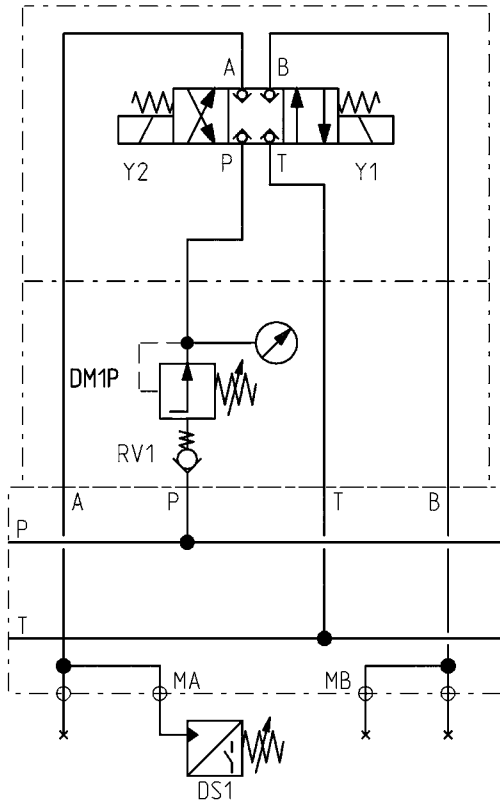

Spacer plates - 3-way pressure-control valve
Control function in P

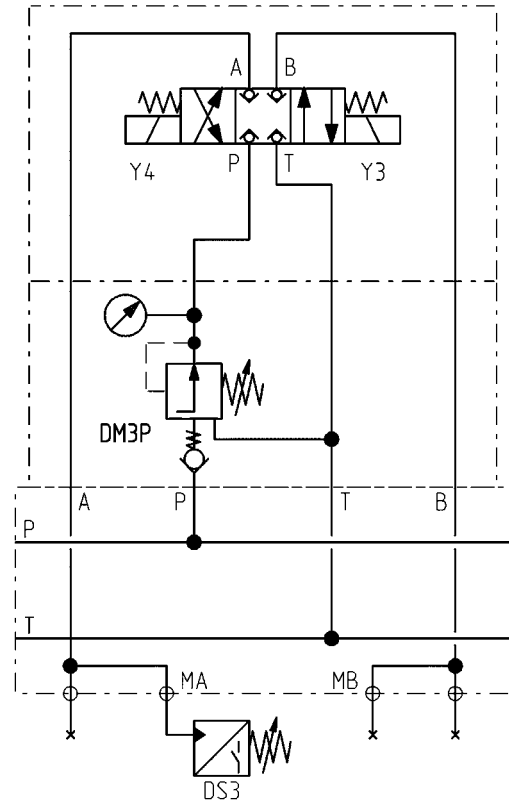

Spacer plates - twin-type
throttle check valve

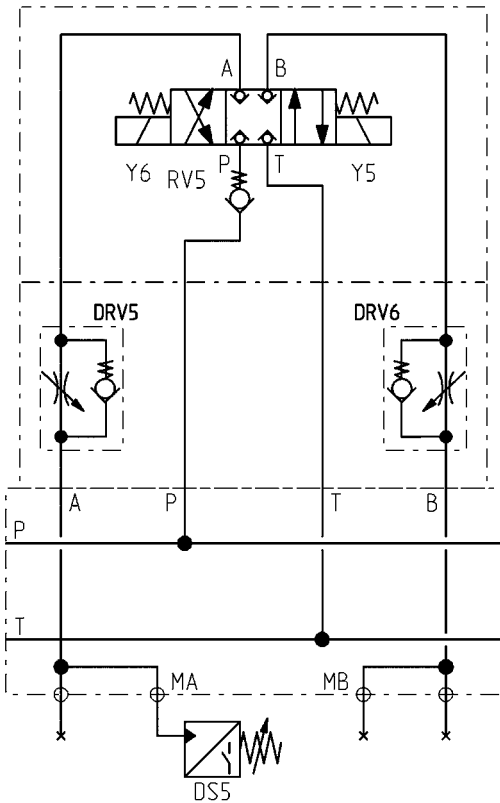

Spacer plate with connectable throttle
Function in P

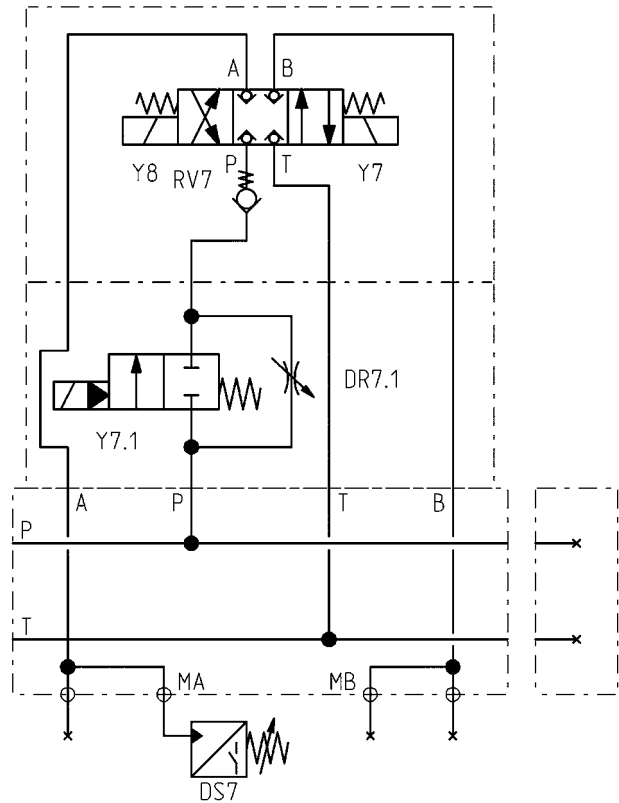

Combination of directional valve zero position, in which A, B and T are connected, plus pressure control in P with two pressure levels in one circuit.

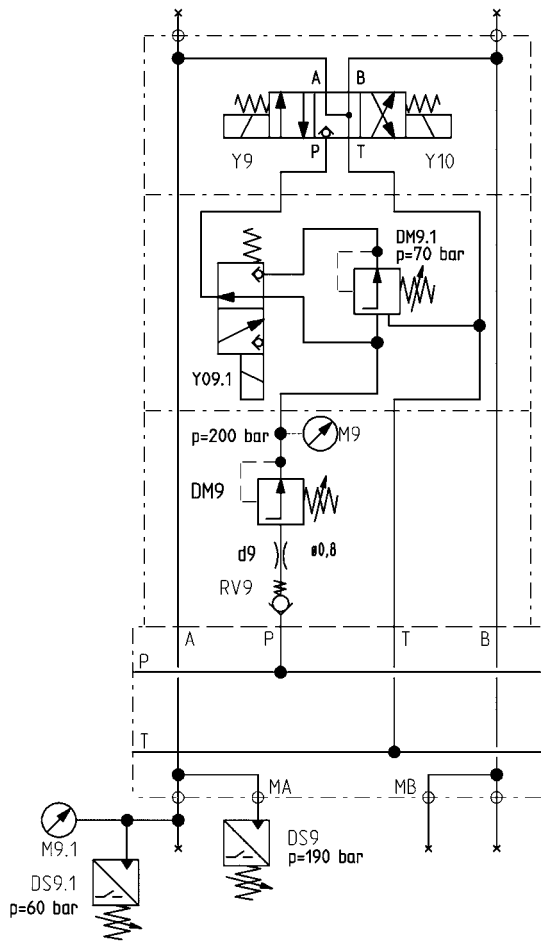

Combination of directional valve zero position, in which A, B and T are connected, plus unlockable check valves at the consumer.

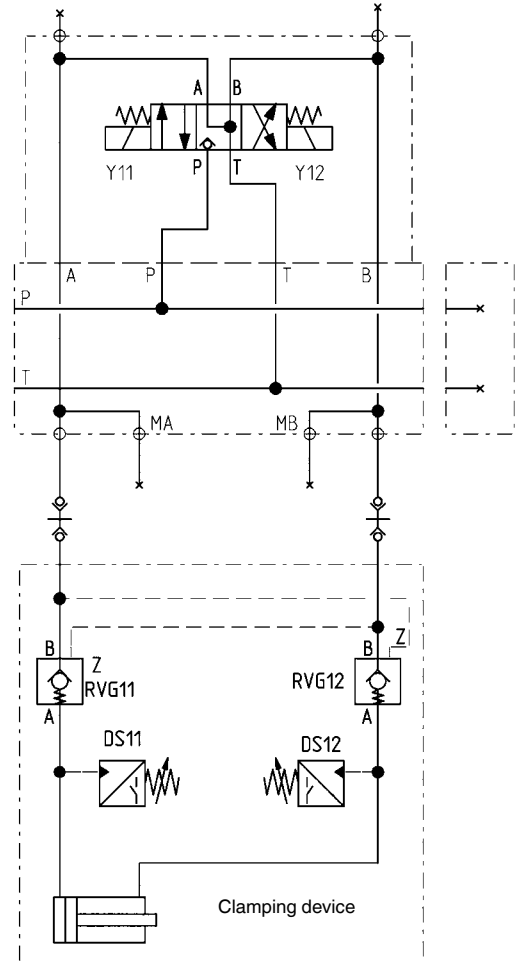

SPECIAL VALVES AVAILABLE ON REQUEST

NO. 6910A-07-02

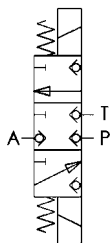

NO. 6911A-07-01

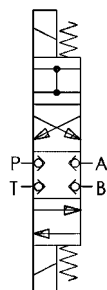

NO. 6911A-07-02

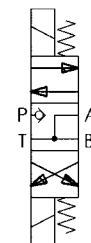

No. 6906BS-1

Coupling Plug

with pin

No. 6906BS-4

Surface-mounted housing

with bush



No. 6906BS-4



No. 6906BS-1

Order no.	Article no.	Control voltage	Number of poles	Weight [g]
60772	6906BS-1	24 V =	24	122
66126	6906BS-4	24 V =	24	145

Design:

Aluminium die-case housing. In locked position - protection class IP65. With crimp connection for socket + crimp contact socket, and crimp connection for pin + crimp contact pin.

Application:

Connection to the machine side.

No. 6906BS-2

Coupling Plug

with bush

No. 6906BS-3

Surface-mounted housing

with pin



No. 6906BS-3



No. 6906BS-2

Order no.	Article no.	Control voltage	Number of poles	Weight [g]
61895	6906BS-2	24 V =	24	122
66118	6906BS-3	24 V =	24	145

Design:

Aluminium die-case housing. In locked position - protection class IP65. With crimp connection for pin + crimp contact pin, and crimp connection for socket + crimp contact socket.

Application:

Connection to the unit side.

No. 6906B-2-1

1-circuit control switch (rotary switch)

No. 6906B-3-2

2-circuit control switch (rotary switch)



No. 6906B-2-1

No. 6906B-3-2

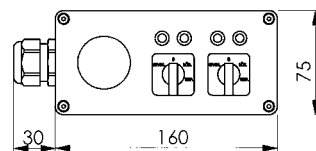
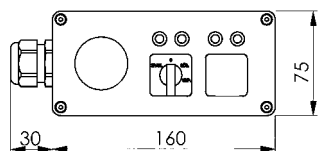
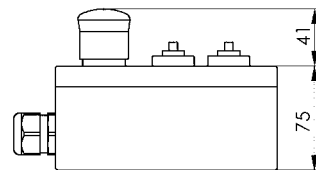
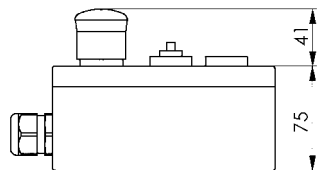

Order no.	Article no.	Control voltage	Number of poles	Cable length [m]	Weight [g]
324723	6906B-2-1	24 V =	24	5	1660
323394	6906B-3-2	24 V =	24	5	1660

Design:

Compact polyester housing with control elements, cable and coupling plug. Protection class IP65.

Application:

Control switches have a „clamping-0-unclamping-coupling“ selector switch and a black STOP mushroom-head pushbutton for stopping the pump and valves (blocking position). During clamping and unclamping the corresponding valve is switched. In the 0 position the valves move to the blocking position. In the coupling position both magnets are switched at the same time. The pump is switched off and the fault lamp on the unit lights up. In addition, readiness for external machine enabling is switched off.

In external machine enabling, the signal „ready for operation“ and one pressure switch on each of the clamping points to be monitored should be integrated.

No. 6906BZH-2

Two-hand safety operator panel

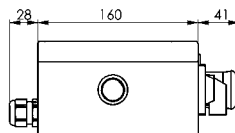
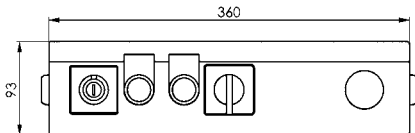

Order no.	Article no.	Control voltage	Cable length [m]	Weight [g]
324426	6906BZH-2	24 V =	3	4840

Design:

Compact cast aluminium housing with control elements, cable and coupling plug.
Base device conforming to EN 574 Type IIIC, IEC 204-1 and EN 954-1. Two-channel control, 1 closer and 1 opener per channel. Monitoring of synchronous actuation. The evaluation device reaches safety category 4 and stop category 0!

Application:

The two-hand control panel may be used only in combination with pump units from Andreas Maier GmbH & Co. KG.
The two-hand control panel is used for controlling fixtures (cylinders, etc.) where dangerous run-out and run-in movements (strokes ≥ 4 mm) can occur.
The following fluid-mechanical system requirements are necessary for the remote control switch to function:
- 4/3 seat valve with hermetically sealed locked zero position.
Alternatively, the combination of a 4/3-way valve, in which A, B and T are connected and P locked in the zero position, with at least one controlled check valve for the dangerous consumer line, or a controlled twin check valve, is possible.
- Install pressure switch in the A and B channels. (The pressure switches must be ordered separately.)
In the AMF pump units, the A-channel is normally assigned to clamping and the B-channel to releasing.

Mounting:

Plug the cable with the plug into the remote control connector of the pump unit. Electrically connect the pressure switch. Set the pressure switch to operate at about 75% of the pressure in the clamping circuit.

Operation:

Key switch for turning on and switching to zero position and coupling position. Rotary switch for selecting the functions - clamping, releasing and zero position. Stop switch to switch off quickly in case of danger. Two-hand pushbutton for initiating movements. Indicator lights signal the control situation.

General:

After a loss of electric power and a subsequent restoration of power, it is necessary to re-clamp. With the standard unit no. 6906, the magnet on the directional control valve remains energised after locking.

Note:

Every user of the two-hand control switch must determine through his own risk analysis what safety category can be achieved for his system or machine.

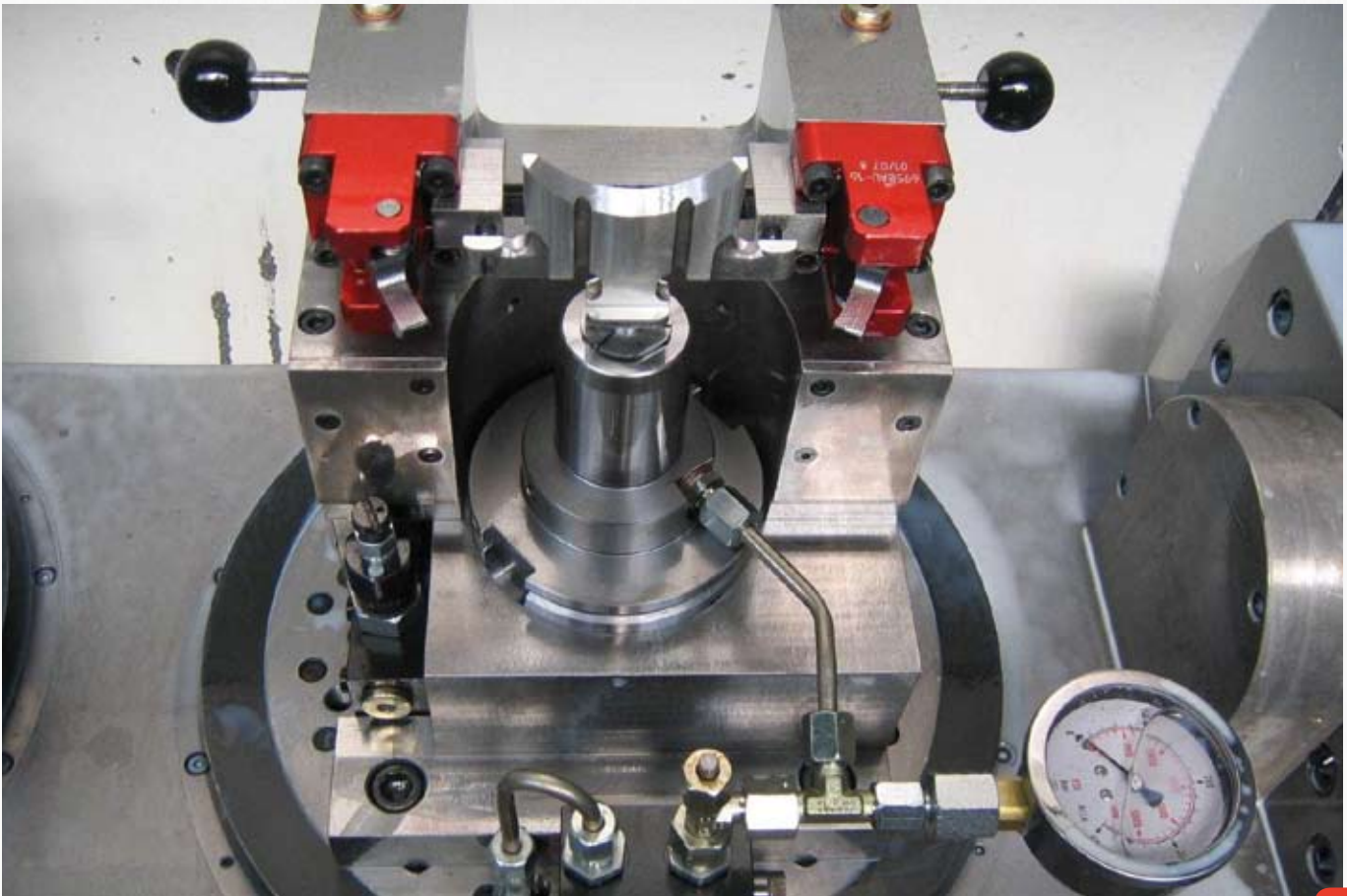

Subject to technical alterations.

HOLLOW-ROD CYLINDER FOR MULTIPLE USE IN MANUFACTURING PROCESSES

- > clamping force up to 188 kN
- > operating pressure up to 500 bar
- > hollow-piston rod with through-hole, with or without internal thread
- > particularly suitable to convert existing mechanical fixtures into hydraulically operated fixtures
- > for push- and pull operation
- > single and double-acting variants
- > wipers to protect against contamination

PRODUCT OVERVIEW:

Type	Clamping force [kN]	Pull force [kN]	Clamping stroke [mm]	No. of models	Operating mode
6920	20 - 125	20 - 125	8 - 20	5	single acting
6920G	20 - 125	20 - 125	8 - 20	5	single acting
6920D	18 - 188	14 - 153	10 - 25	6	double acting
6921	71 - 110	71 - 110	6 - 10	2	single acting
6935	20 - 53	20 - 53	6,5 - 12,5	6	single / double acting

PRODUCT EXAMPLES:

NO. 6920



- > Clamping force: 20 - 125 kN
- > cylinder housing: without external thread

NO. 6920D



- > Clamping force: 18 - 188 kN
- > cylinder housing: with external thread

NO. 6935



- > Clamping force: 20 - 53 kN
- > cylinder housing: nitrided, without external thread, compact design

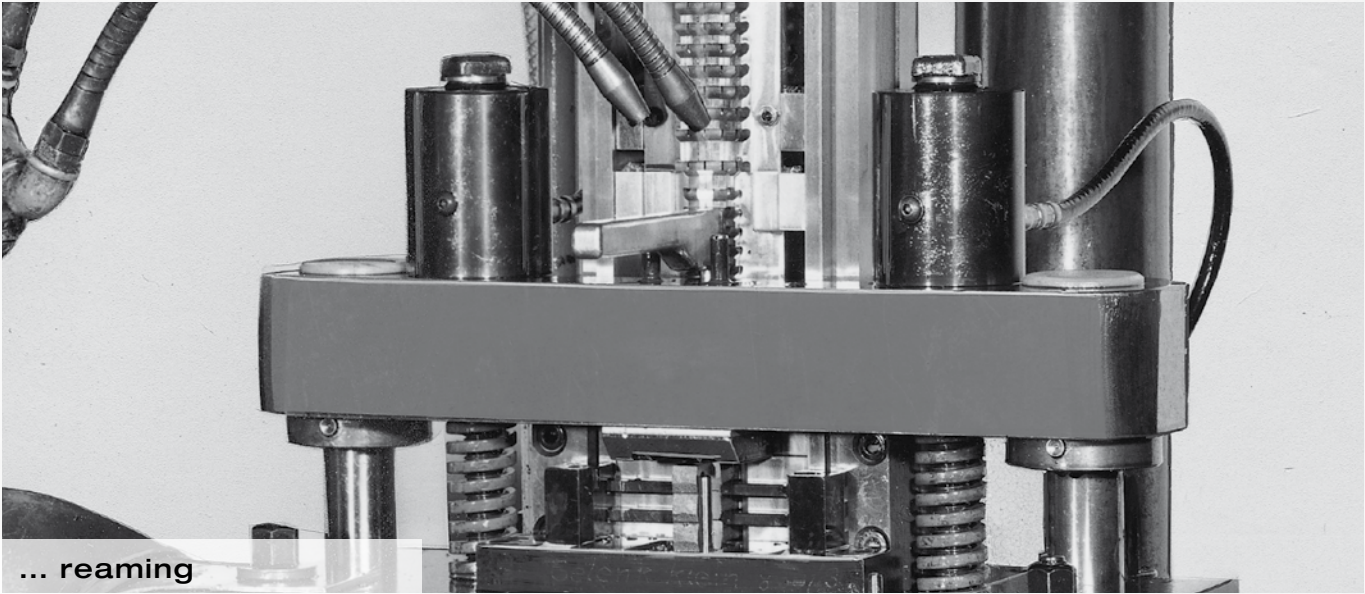

... reaming

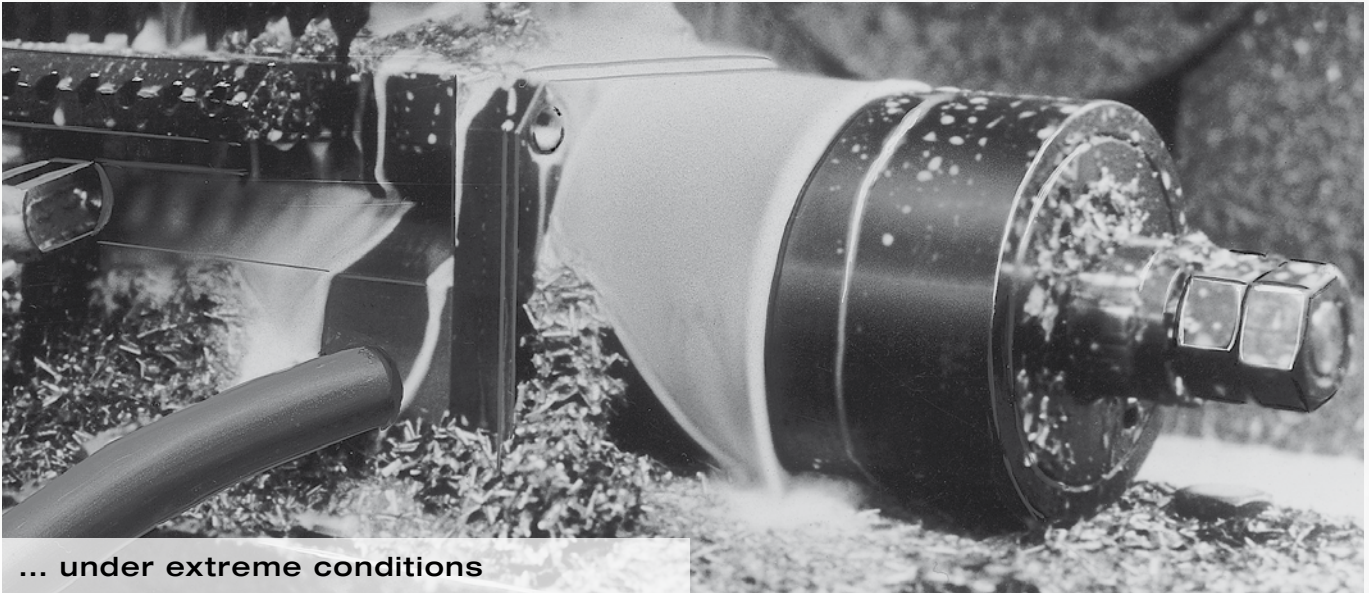

... under extreme conditions

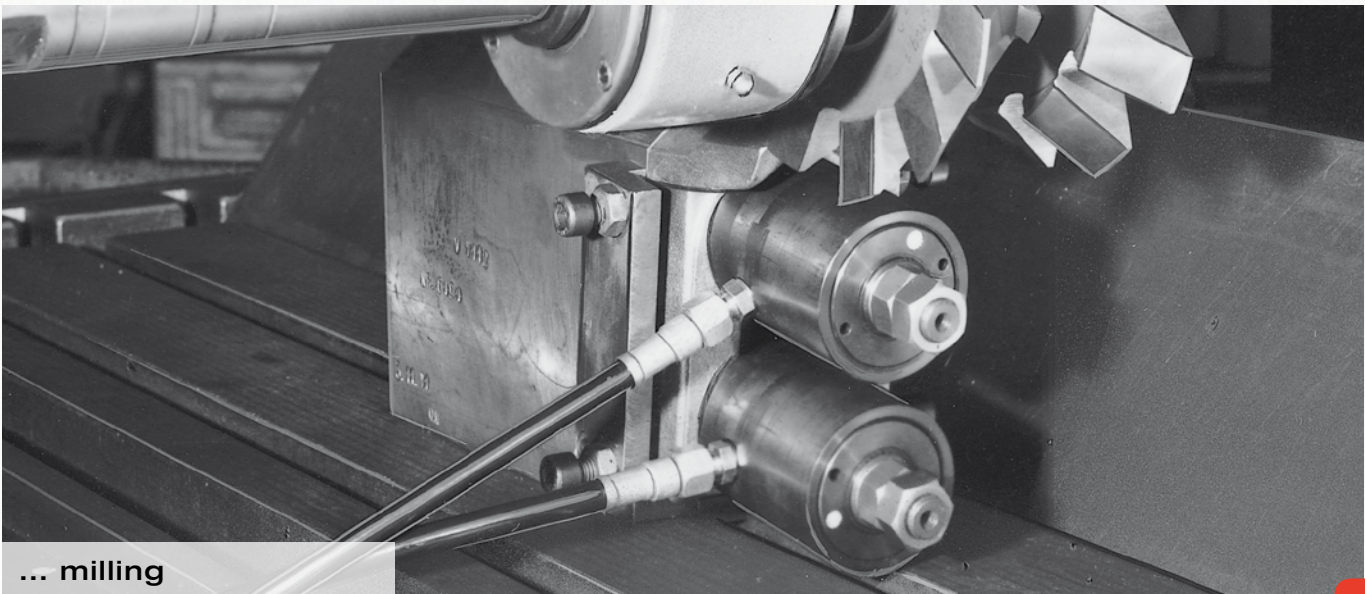

... milling

No. 6920

Hollow Rod Cylinder

single acting, spring return,
max. operating pressure 400 bar.

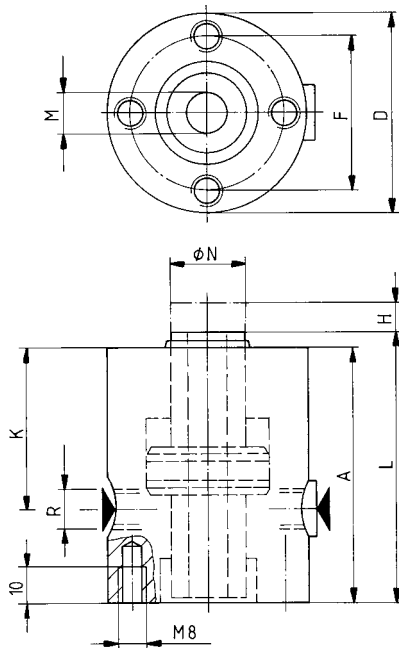

Order no.	Article no.	push-pull force at 100 bar [kN]	push-pull force at 400 bar [kN]	Stroke H [mm]	Vol. [cm ³]	Piston dia. [mm]	effective piston area [cm ²]	Spring force min. [N]	Weight [g]
64998	6920-20	5,0	20	8	4	32	4,9	200	930
63016	6920-32	8,0	32	10	8	40	8,0	350	1730
65011	6920-50	12,5	50	12	15	48	12,8	540	1650
63057	6920-80	20,0	80	15	30	60	20,0	750	3850
65003	6920-125	32,0	125	20	64	75	32,8	1120	6250

Design:

Cylinder housing made of steel, blued. Piston and piston rod case-hardened and ground. Built-in return spring. Sinter metal breather. Two wipers and vent screw.

Application:

Particularly suitable for retrofitting existing fixtures for hydraulic actuation. When workpieces are clamped onto a machine tool table, the hollow rod cylinder can be fitted over the clamp bolt instead of the nut. The hollow rod cylinders can be used for push or pull applications.

Features:

Completely sealed against contamination and chips by means of sinter metal breather and two wipers. Piston can be moved to its end stop. Oil connection at both ends, thus easy lining up in series.

Note:

Cylinders are designed for use in combination with tempered bolts, material grade 8.8, e. g. DIN 787 and DIN 6379. Bolts matching the hole are recommended. For single acting cylinders there is risk of sucking in coolant during the return stroke. In this case the cylinders have to be protected against the direct effect of coolant. The sinter metal breather should be protected.

Dimensions

Order no.	Article no.	A	dia. D	dia. F	K	L	dia. M	dia. N	R
64998	6920-20	80	52	40	56,0	82	12,5	20	G1/8
63016	6920-32	90	60	44	60,5	94	14,5	24	G1/8
65011	6920-50	101	70	50	71,5	103	18,5	26	G1/8
63057	6920-80	115	80	60	87,0	119	22,5	32	G1/4
65003	6920-125	149	100	75	108,0	151	27,5	38	G1/4

Hollow-piston cylinder no. 6920/50 in milling device for link lever.

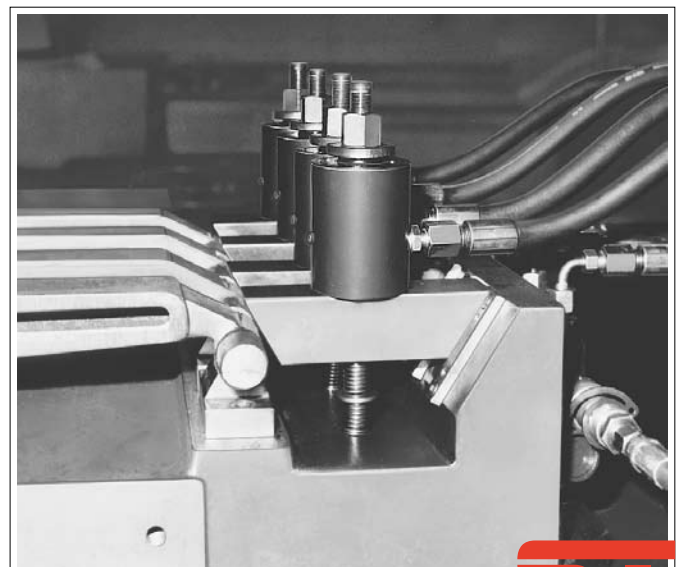

No. 6920G

Hollow Rod Cylinder with internal thread

single acting, spring return,
max. operating pressure 400 bar.

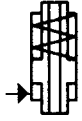

Order no.	Article no.	push-pull force at 100 bar [kN]	push-pull force at 400 bar [kN]	Stroke H [mm]	Vol. [cm ³]	Piston dia. [mm]	effective piston area [cm ²]	Spring force min. [N]	Weight [g]
65318	6920G-20	5,0	20	8	4	32	4,9	200	1000
63032	6920G-32	8,0	32	10	8	40	8,0	350	1750
65334	6920G-50	12,5	50	12	15	48	12,8	540	1700
63073	6920G-80	20,0	80	15	30	60	20,0	750	3900
65359	6920G-125	32,0	125	20	64	75	32,8	1120	6400

Design:

Cylinder housing made of steel, blued. Piston and piston rod case-hardened and ground. Built-in return spring. Sinter metal breather. Two wipers and vent screw.

Application:

Particularly suitable for retrofitting existing fixtures for hydraulic actuation. When workpieces are clamped onto a machine tool table, the hollow rod cylinder can be fitted over the clamp bolt instead of the nut. The hollow rod cylinders can be used for push or pull applications.

Features:

Completely sealed against contamination and chips by means of sinter metal breather and two wipers. Piston can be moved to its end stop. Oil connection at both ends, thus easy lining up in series.

Note:

Cylinder size 20 to 50 are designed for use in combination with tempered bolts, material grade 8.8. For size 80 and 125 bolts of material grade 12.9 must be used. For single acting cylinders there is risk of sucking in coolant during the return stroke. In this case the cylinders have to be protected against the direct effect of coolant. The built in sinter metal breather should be protected.

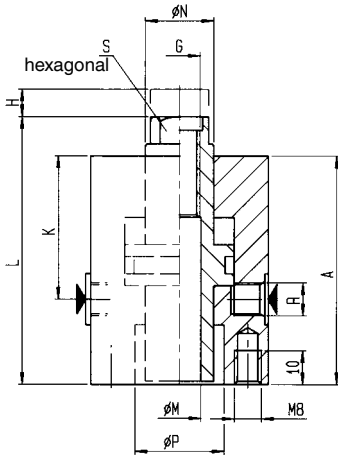
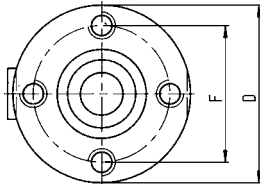

Dimensions

Order no.	Article no.	A	dia. D	dia. F	K	L	dia. M	dia. N	R	P	GxLength	S
65318	6920G-20	80	52	40	56,0	90,0	12,5	20	G1/8	27	M12x29	17
63032	6920G-32	90	60	44	60,5	101,5	14,5	24	G1/8	30	M14x30	19
65334	6920G-50	101	70	50	71,5	113,0	16,5	26	G1/8	35	M16x39	22
63073	6920G-80	115	80	60	87,0	132,5	18,5	32	G1/4	38	M18x38	27
65359	6920G-125	149	100	75	108,0	163,0	20,5	38	G1/4	49	M20x47	32

Hollow-piston cylinder no. 6920G/125 in powder welding system for clamping of U-profile panels.

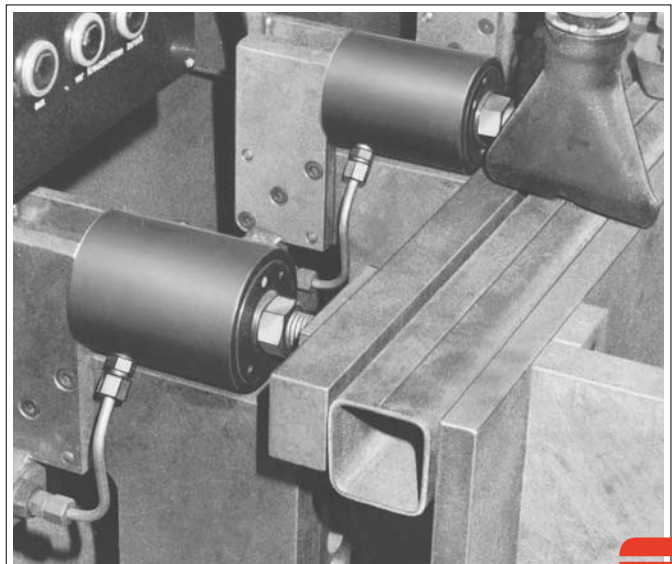

Subject to technical alterations.

No. 6920D

Hollow Rod Cylinder

double acting,
max. operating pressure 500 bar.

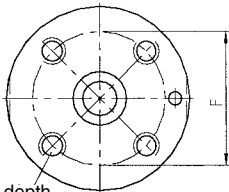
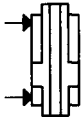

M8 10 depth

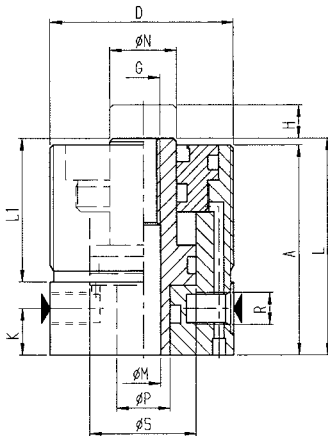

Order no.	Article no.	push-pull force				Stroke H [mm]	Vol. work stroke [cm³]	Vol. back stroke [cm³]	effective piston area work stroke [cm²]	effective piston area back stroke [cm²]	Weight [g]
		work stroke at 100 bar [kN]	work stroke at 500 bar [kN]	back stroke at 100 bar [kN]	back stroke at 500 bar [kN]						
62794	6920D-15-001	3,77	18,85	2,89	14,45	10	3,77	2,89	3,77	2,89	850
62836	6920D-24-001	6,03	30,15	4,90	24,50	10	6,03	4,90	6,03	4,90	1100
62844	6920D-38-001	9,42	47,10	7,65	38,25	16	15,10	12,20	9,42	7,65	1650
62851	6929D-59-001	14,72	73,60	11,59	57,95	16	23,50	18,50	14,72	11,59	2000
62869	6920D-92-001	23,12	115,60	18,60	93,00	20	46,20	37,20	23,12	18,60	3050
62877	6920D-150-001	37,68	188,40	30,63	153,15	25	94,20	76,50	37,68	30,63	5350

Design:

Cylinder housing made of steel, blued. Piston case-hardened and ground. Piston rod is always furnished with HC thread. If a piston rod with internal thread is desired, a HELI-COIL insert (diameter x1.5) is screwed into the HC thread.

Application:

Particularly suitable for retrofitting existing fixtures for hydraulic actuation. When workpieces are clamped onto a machine tool table, the hollow rod cylinder can be fitted over the clamp bolt instead of the nut. The hollow rod cylinders can be used for push or pull applications.

Note:

Cylinders are designed for use in combination with tempered bolts, material grade 12.9 (e.g. DIN 787). Threaded body provides a wide range of adjustability. Suitable flange nuts DIN 70852.

Dimensions

Order no.	Article no.	A	D	dia. F	G	K	L	L1	dia. M	dia. N	dia. P	R	dia. S
62794	6920D-15-001	59	M50x1,5	35	HCM 8	11	60	36	8,2	16	12	G1/8	25
62836	6920D-24-001	64	M55x1,5	40	HCM 10	12	65	41	10,2	20	16	G1/4	32
62844	6920D-38-001	72	M65x1,5	45	HCM 12	14	73	45	12,2	25	20	G1/4	40
62851	6929D-59-001	78	M70x1,5	50	HCM 16	14	79	50	16,2	32	25	G1/4	50
62869	6920D-92-001	95	M80x2,0	60	HCM 20	18	96	60	20,2	40	32	G1/4	63
62877	6920D-150-001	109	M100x2,0	75	HCM 27	22	110	65	27,2	50	40	G1/4	80

Accessories: HELI-COIL-Thread insert



Order no.	Thread insert	for cylinder size
67538	M 8x12	6920D-15-001
67546	M10x15	6920D-24-001
67595	M12x18	6920D-38-001
67603	M16x24	6920D-59-001
67611	M20x30	6920D-92-001
67629	M27x40,5	6920D-150-001

Note:

The HELI-COIL thread insert can be installed using a manual or automatic installation tool. The driving pin is used only for installation, and must subsequently be removed using a special pin-breaker. Without the HELI-COIL insert the piston through-hole has the value of the gap $\varnothing M$ (see dimensions table).

No. 6921

Hollow Rod Cylinder

single acting, spring return,
max. operating pressure 400 bar.

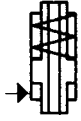

Order no.	Article no.	push-pull force at 100 bar [kN]	push-pull force at 400 bar [kN]	Stroke H [mm]	Vol. [cm ³]	Piston dia. [mm]	effective piston area [cm ²]	Spring force min. [N]	Weight [g]
63768	6921-70x6	17,8	71	6	11	55	18,5	700	1675
63149	6921-100x10	24,4	101	10	26	70	25,9	1500	4800

Design:

Cylinder housing made of steel, blued. Piston and piston rod case-hardened and ground. Retraction by disc spring. One wiper. Piston rod with internal thread and two flats (size 70x6) or hexagon (size 100x10). Sinter metal breather.

Application:

When workpieces are clamped onto a machine tool table, the hollow rod cylinder can be screwed onto the clamp bolt and be joined to the clamp by the two threads in the body. Also suitable for holding and clamping devices directly on a machine tool table. The hollow rod cylinder is designed for use in combination with tempered bolts of material grade 8.8 for size 100x10 and material grade 12.9 for the size 70x6. In case bolts of material grade 8.8 and grade 10.9 are used the pressure has to be reduced for size 70x6 for continuous operation (see diagramme).

Features:

Protected against contamination and chips by a wiper. High forces in a small design.

Note:

For single acting cylinders there is risk of sucking in coolant during the return stroke. In this case the cylinders have to be protected against the direct effect of coolant. The built in sinter metal breather should be protected.

Dimensions

Order no.	Article no.	A	B	dia. C	dia. D	E	F	G	K	L	M	R	S
63768	6921-70x6	58	10	16,5	75	26	50	M8	13	65	M16	G1/4	SW22
63149	6921-100x10	85	10	25,0	100	56	70	M10	16	97	M24	G1/4	SW36

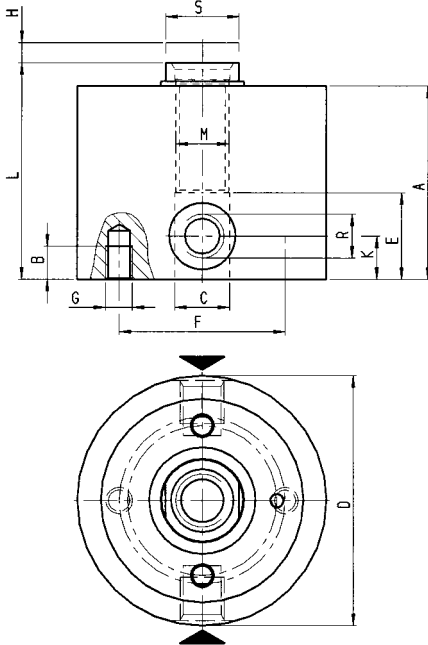

Application example:

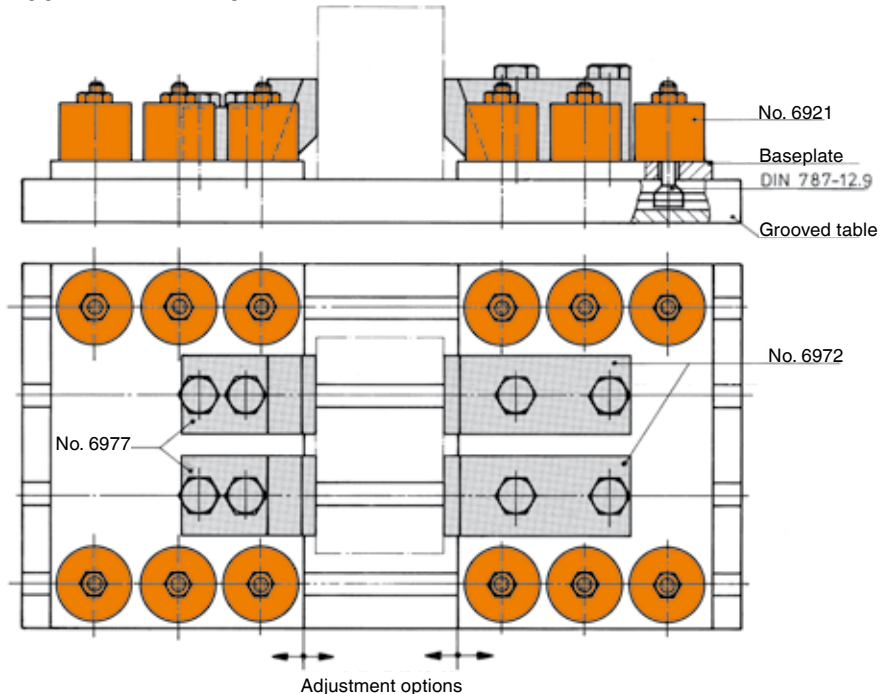
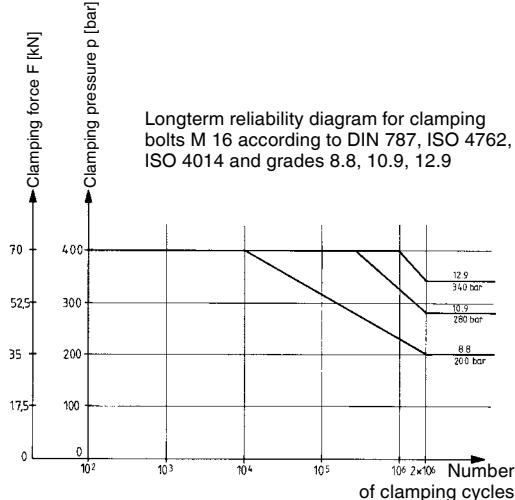

Diagram for size 70x6



The shown hydraulic clamping device shows casts of several sizes that are clamped by hydraulic pull-down clamp no. 6972F and pull-down counterpart no. 6977. To obtain an efficient means of adjustment, 2 base plates are each equipped with 6 hydraulic nuts no. 6921 which are connected to the grooved table via bolts for T-nut according to DIN 787. The adjustment of the base plate and the clamping of the workpiece can be performed independently by a pump unit with 2 clamping circuits.

No. 6921S

Hollow Rod Cylinder with mechanic locking

single acting, spring return.

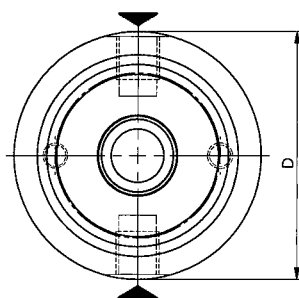
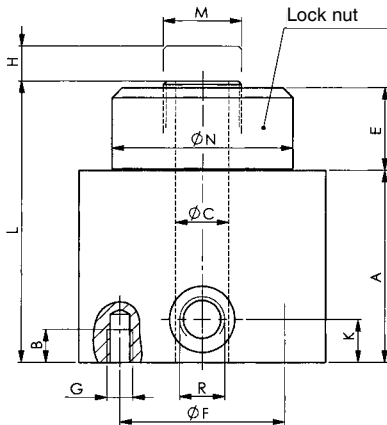
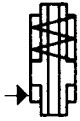

Order no.	Article no.	push-pull force at 100 bar [kN]	push-pull force at 250 bar [kN]	Max. operating pressure [bar]	Stroke H [mm]	Vol. [cm ³]	Piston dia. [mm]	effective piston area [cm ²]	Spring force min. [N]	Weight [g]
69047	6921S-46x 6	17,8	45,5	250	6	11	55	18,5	700	2150
69005	6921S-77x100	24,4	63,2	300	10	26	70	25,9	1500	5150

Design:

Cylinder housing made of steel, blued. Piston and piston rod case-hardened and ground. Retraction by disc springs. Locking enable due external thread on piston rod and hand-locking nut. Wiper to protect against contamination.

Application:

Typical use on injection molding machines and presses to hold the molds and dies.

Features:

After clamping process the piston will be kept and secured in clamping position by fastening the hand nut. Hydraulic pressure can be released and the power source disconnected. For unclamping, the cylinder has to be pressurised in order to allow a free movement of the hand nut back into its original position.

Note:

For single acting cylinders there is risk of sucking in coolant during the return stroke. In this case the cylinders have to be protected against the direct effect of coolant. The built in sinter metal breather should be protected.

Dimensions

Order no.	Article no.	A	B	dia. C	dia. D	E	F	G	K	L	M	dia. N	R
69047	6921S-46x 6	58	10	16,2	75	25	50	M 8	13	85	M24x1,5	55	G1/4
69005	6921S-77x100	85	10	24,2	100	30	70	M10	16	118	M38x1,5	70	G1/4

The figure shows hydraulic nuts no. 6921S clamping an injection mould. The hydraulic nuts are uncoupled from the pressure generator, with the tension being provided by the lock nut.

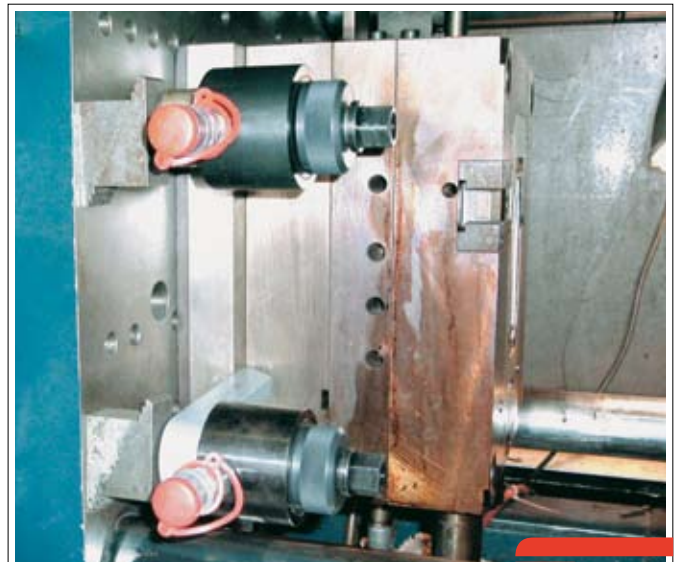

No. 6935

Hollow Rod Cylinder with internal thread

single and double acting,
max. operating pressure 350 bar.

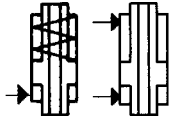

Order no.	Article no.	push-pull force				Stoke B [mm]	Vol. [cm ³]	effective piston area [cm ²]	Weight [g]
		work stroke at 100 bar [kN]	work stroke at 350 bar [kN]	back stroke at 100 bar [kN]	back stroke at 350 bar [kN]				
67850	6935-20	5,8	20,6	-	-	6,5	3,8	5,9	572
67876	6935-30	8,4	29,7	-	-	9,5	8,1	8,5	940
67892	6935-53	15,2	53,2	-	-	12,5	19,3	15,2	1837
67918	6935D-20	5,8	20,6	5,8	20,6	6,5	3,8	5,9	572
67934	6935D-30	8,4	29,7	8,4	29,7	9,5	8,1	8,5	940
67959	6935D-53	15,2	53,2	15,2	53,2	12,5	19,3	15,2	1837

Design:

Cylinder housing made of steel, hardened and blued. Piston and piston rod case-hardened and ground. Piston rod with internal thread. Wiper at piston rod. Return spring made of stainless steel.

Application:

Particularly suitable to retrofit existing mechanical fixtures for hydraulic actuation. The hollow cylinder can be operated as push or pull cylinder. Universal cylinder for clamping, pushing, locking and punching.

Features:

Clamping cylinder with tapped piston rod. Tapped piston rod ends allow the use of custom end attachments.

Note:

For single acting cylinders there is the risk of sucking in coolant through the breather port. Therefore, the sinter metal breather has to be protected e.g. by cover plates from direct access of coolant. The system has to be completely vented thoroughly during installation.

Dimensions

Order no.	Article no.	A	C	D	E	F	G	H	J	K	L	M	N	P	Q	S
67850	6935-20	51,0	7,0	43,5	41,5	32	M10	28,5	M6x6	10,5	12	20,5	15	55	16,0	39,5
67876	6935-30	63,5	7,0	56,5	49,5	36	M12	24,5	M8x8	13,5	18	25,5	15	62	19,0	47,5
67892	6935-53	76,0	9,5	66,0	64,5	50	M16	25,0	M10x13	16,5	23	30,0	18	76	25,5	63,5
67918	6935D-20	51,0	7,0	43,5	41,5	32	M10	28,5	M6x6	10,5	12	20,5	15	55	16,0	39,5
67934	6935D-30	63,5	7,0	56,5	49,5	36	M12	24,5	M8x8	13,5	18	25,5	15	62	19,0	47,5
67959	6935D-53	76,0	9,5	66,0	64,5	50	M16	25,0	M10x13	16,5	23	30,0	18	76	25,5	63,5

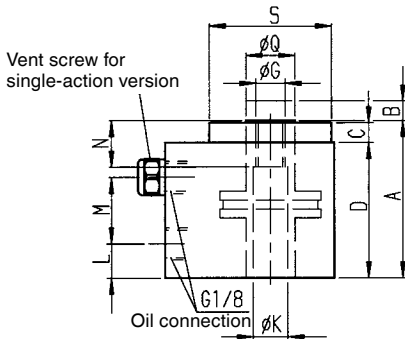
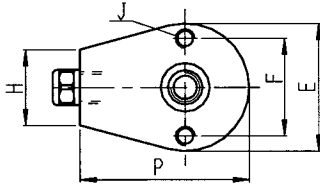

BUILT-IN CYLINDERS FOR UNIVERSAL USE

- > clamping force up to 70 kN
- > operating pressure up to 400 bar
- > piston with and without internal thread
- > for push- and pull operation
- > quick adjustment, secured using standard grooved nuts
- > single and double acting variants
- > wipers to protect against contamination

PRODUCT OVERVIEW:

Type	Clamping force [kN]	Clamping stroke [mm]	No. of models	Operating mode
6924	4,5 - 70	6 - 15	7	single acting
6925	4,4 - 39,9	6,5 - 32	11	single acting
6925D	17,8 - 39,9	25,5 - 51	4	double acting

PRODUCT EXAMPLES:

NO. 6924



- > Clamping force: 4,5 - 70 kN
- > cylinder housing: with fine thread

NO. 6925



- > Clamping force: 4,4 - 39,9 kN
- > cylinder housing: nitrided, with fine thread

NO. 6925D



- > Clamping force: 17,8 - 39,9 kN
- > cylinder housing: nitrided, with fine thread

No. 6924

Built-In Cylinder

single acting, spring return,
max. operating pressure 400 bar.

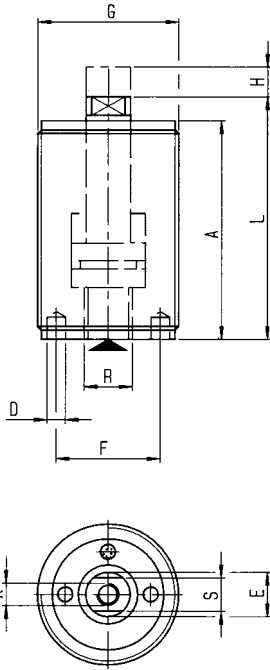
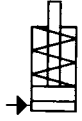

Order no.	Article no.	push-pull force at 100 bar [kN]	push-pull force at 400 bar [kN]	Stroke H [mm]	Vol. [cm ³]	Piston dia. [mm]	effective piston area [cm ²]	Spring force min. [N]	Weight [g]
63024	6924-05	1,1	4,5	6	0,66	12	1,1	45	300
63099	6924-08	2,0	8,0	6	1,20	16	2,0	60	270
63115	6924-12	3,0	12,0	8	2,50	20	3,1	95	480
63131	6924-20	5,0	20,0	8	4,00	25	4,9	205	500
63164	6924-32	8,0	32,0	10	8,00	32	8,0	340	850
63156	6924-50	12,5	50,0	12	15,00	40	12,5	400	1450
63180	6924-70	17,5	70,0	15	27,00	48	18,0	650	2050

Design:

Cylinder made of steel, blued. Piston and piston rod case-hardened and ground. Built-in return spring. Sinter metal breather. Wiper at piston rod. Cylinder housing with metric thread for flange nuts DIN 70852.

Application:

Suitable for converting mechanical to hydraulic clamping devices. The built-in cylinder is inserted in through holes and counter screwed at both ends with grooved nuts. General-purpose clamping element for clamping, pushing, pressing, riveting and punching.

Features:

The metric thread extending over the whole length of the cylinder permits with its two flange nuts DIN 70852 lengthwise adjustment over a large range and fast positioning in the required by two flange nuts. Fast attachment of fixture elements and thrust pieces the piston thread.

Note:

For single acting cylinder types there is a risk of sucking coolant liquid at the return stroke. In this case the cylinder has to be protected against the direct effect of coolant. The built in sinter metal breather should be protected.

Dimensions

Order no.	Article no.	A	dia. D	dia. E	F	G	K x depth	L	S	R
63024	6924-05	50,0	4	8	20	M30x1,5	M4x10	56,0	6	G1/8
63099	6924-08	46,5	4	10	20	M32x1,5	M5x12	52,5	8	G1/8
63115	6924-12	59,0	5	12	28	M38x1,5	M6x14	65,5	9	G1/4
63131	6924-20	63,5	4	12	25	M40x1,5	M8x20	70,5	10	G1/4
63164	6924-32	72,0	4	16	30	M48x1,5	M10x25	81,0	13	G1/4
63156	6924-50	80,0	5	20	35	M60x1,5	M12x28	89,0	17	G1/4
63180	6924-70	93,0	6	25	44	M70x1,5	M16x35	105,0	22	G1/4

DIN 70852

Flange Nut

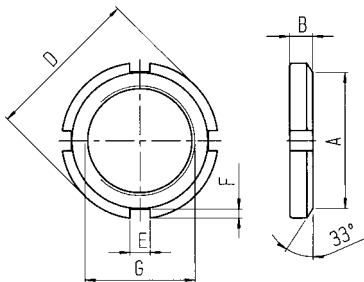

Order no.	Article no.	dia. A	B	dia. D	E	F	G	No's grooves	Weight [g]
63974	70852-M20	27	6	32	5,5	2,3	M20x1,5	4	19
63784	70852-M28	36	7	42	6,5	2,8	M28x1,5	4	35
63792	70852-M30	38	7	44	6,5	2,8	M30x1,5	4	36
63800	70852-M32	41	8	48	7,0	3,3	M32x1,5	4	52
63818	70852-M35	43	8	50	7,0	3,3	M35x1,5	4	51
63826	70852-M38	47	8	54	7,0	3,3	M38x1,5	4	60
63834	70852-M40	49	8	56	7,0	3,3	M40x1,5	4	62
63842	70852-M48	57	8	65	8,0	3,8	M48x1,5	6	75
63859	70852-M50	60	8	68	8,0	3,8	M50x1,5	6	84
63867	70852-M52	62	8	70	8,0	3,8	M52x1,5	6	87
63875	70852-M55	67	8	75	8,0	3,8	M55x1,5	6	100
63883	70852-M58 *	71	9	80	11,0	4,3	M58x1,5	6	140
63891	70852-M60	71	9	80	11,0	4,3	M60x1,5	6	130
63909	70852-M65	76	9	85	11,0	4,3	M65x1,5	6	130
63917	70852-M70	81	9	90	11,0	4,3	M70x1,5	6	140
63925	70852-M80 *	91	10	100	11,0	4,3	M80x2,0	6	180
267062	70852-M85 *	99	10	108	11,0	4,3	M85x2,0	6	239
63933	70852-M100 *	116	10	125	11,0	4,3	M100x2,0	6	299

* not to DIN

Design:

Steel, zinc-plated.

Application:

The flange nuts hold cylinders in the required position.

Subject to technical alterations.

No. 6925

Built-In Cylinder

single acting,
max. operating pressure 350 bar.



No. 6925-04



No. 6925-10

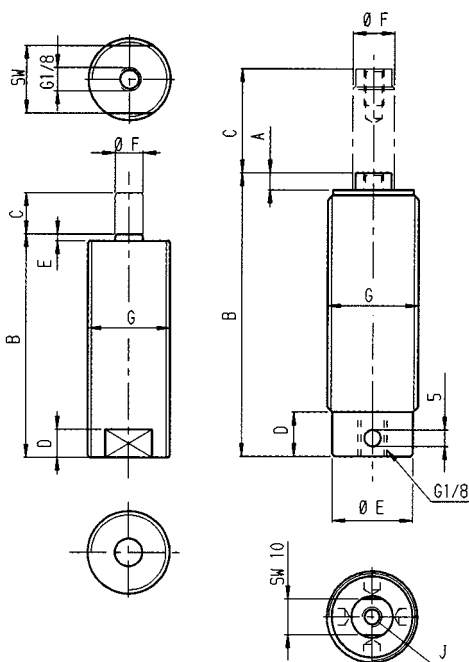

No. 6925-04

No. 6925-10

Order no.	Article no.	Push force at 100 bar [kN]	Push force at 350 bar [kN]	Stroke C [mm]	Vol. [cm ³]	Piston area [cm ²]	Weight [g]
67975	6925-04-1	1,25	4,4	9,5	1,2	1,3	73
67991	6925-04-2	1,25	4,4	19,0	2,5	1,3	91
68015	6925-04-3	1,25	4,4	32,0	4,1	1,3	118
68031	6925-10-1	2,88	10,1	6,5	1,8	2,9	200
67801	6925-10-2	2,88	10,1	19,0	5,5	2,9	210
67827	6925-10-3	2,88	10,1	32,0	9,2	2,9	254

Design:

Cylinder housing made of steel, hardened and blued. Piston and piston rod case-hardened and ground. Piston rod with internal thread. Wiper at piston rod. Cylinder housing with metric fine thread for flange nut as per DIN 70852. Return spring out of stainless steel.

Application:

Suitable to convert mechanical fixtures into hydraulic operated. The built-in cylinder can easily be mounted and adjusted into fixture walls by grooved nuts. Universal cylinder for clamping, pushing, locking and rivetting.

Features:

The metric thread extending over the whole length of the cylinder permits with its two flange nuts DIN 70852 lengthwise adjustment over a large range. Tapped piston rod end allows the use of individual contact bolts.

Note:

The system has to be completely vented during installation.

Dimensions

Order no.	Article no.	A	B	C	D	E	F	G	J	SW
67975	6925-04-1	-	51,0	9,5	6,5	1,5	6,5	M20x1,5	-	16
67991	6925-04-2	-	65,5	19,0	6,5	1,5	6,5	M20x1,5	-	16
68015	6925-04-3	-	83,0	32,0	6,5	1,5	6,5	M20x1,5	-	16
68031	6925-10-1	6,5	55,5	6,5	12,5	24,5	12,5	M28x1,5	M6x11	-
67801	6925-10-2	6,5	68,5	19,0	12,5	24,5	12,5	M28x1,5	M6x11	-
67827	6925-10-3	5,0	86,0	32,0	12,5	24,5	12,5	M28x1,5	M6x11	-



No. 6925D

Built-In Cylinder

single and double acting,
max. operating pressure 350 bar.

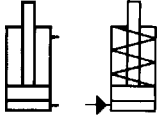

G1/8 Oil connection of
single-acting version

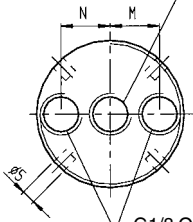

G1/8 Oil connection of
double-acting version

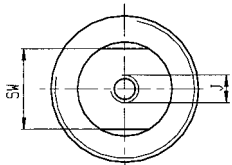
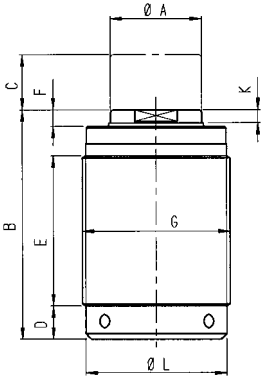

Order no.	Article no.	Push force at 100 bar [kN]	Pull force at 100 bar [kN]	Push force at 350 bar [kN]	Pull force at 350 bar [kN]	Stroke C [mm]	Vol. work stroke [cm³]	Piston area push [cm²]	Weight [g]
67843	6925-18-1	5,08	-	17,8	-	12,5	6,4	5,1	304
67868	6925-18-2	5,08	-	17,8	-	25,5	13,0	5,1	354
67884	6925-18-3	5,08	-	17,8	-	51,0	26,0	5,1	463
67900	6925-40-1	11,40	-	39,9	-	12,5	14,2	11,4	644
67926	6925-40-2	11,40	-	39,9	-	25,5	29,0	11,4	744
67942	6925D-18-1	5,08	1,6	17,8	5,9	25,5	13,0	5,1	762
67967	6925D-18-2	5,08	1,6	17,8	5,9	51,0	26,0	5,1	1061
67983	6925D-40-1	11,40	5,0	39,9	17,5	25,5	29,0	11,4	1379
68007	6925D-40-2	11,40	5,0	39,9	17,5	51,0	58,1	11,4	1869

Design:

Cylinder housing made of steel, hardened and blued. Piston and piston rod case-hardened and ground. Piston rod with internal thread. Wiper at piston rod. Cylinder housing with metric fine thread for flange nut as per DIN 70852.

Application:

Suitable to convert mechanical fixtures into hydraulic operated. The built-in cylinder can easily be mounted and adjusted into fixture walls by flange nuts. Universal cylinder for clamping, pushing, locking, rivetting and punching.

Features:

The metric thread extending over the whole length of the cylinder permits with its two flange nuts DIN 70852 lengthwise adjustment over a large range. Tapped piston rod end allows the use of individual contact bolts.

Note:

The system has to be completely vented during installation.

Dimensions

Order no.	Article no.	A	B	D	E	F	G	SW	J	K	L	M	N
67843	6925-18-1	20,1	68,0	12,5	39,5	8	M35x1,5	17	M8x11	6,5	30,5	-	-
67868	6925-18-2	20,1	80,5	12,5	52,5	8	M35x1,5	17	M8x11	6,5	30,5	-	-
67884	6925-18-3	20,1	109,0	12,5	81,0	8	M35x1,5	17	M8x11	6,5	30,5	-	-
67900	6925-40-1	28,2	70,0	12,5	39,5	10	M48x1,5	25	M12x13	9,0	45,0	-	-
67926	6925-40-2	28,2	83,0	12,5	52,5	10	M48x1,5	25	M12x13	9,0	45,0	-	-
67942	6925D-18-1	20,1	80,5	12,5	52,5	8	M48x1,5	17	M8x11	6,5	45,0	14,0	14
67967	6925D-18-2	20,1	109,0	12,5	81,0	8	M48x1,5	17	M8x11	6,5	45,0	14,0	14
67983	6925D-40-1	28,2	82,0	12,5	52,5	10	M65x1,5	25	M12x13	9,0	60,5	20,5	11
68007	6925D-40-2	28,2	111,0	12,5	81,0	10	M65x1,5	25	M12x13	9,0	60,5	20,5	11

THREADED CYLINDERS - SPACE-SAVING AND EASY TO INSTALL

- > clamping force up to 40 kN
- > operating pressure up to 500 bar
- > piston with and without internal thread
- > wipers to protect against contamination
- > oil supply via fixture body
- > single and double-acting variants

PRODUCT OVERVIEW:

Type	Clamping force [kN]	Clamping stroke [mm]	No. of models	Operating mode
6929	2,5 - 40,0	5 - 20	8	single-acting
6930	5,5 - 40,0	10 - 20	5	single-acting
6930D	4,5 - 50,0	12 - 40	6	double-acting
6932	2,5 - 24,5	4 - 12	5	single-acting
6933	5,5 - 40,0	8 - 12	5	single-acting
6934	2,4 - 17,5	5 - 19	5	single-acting

PRODUCT EXAMPLES:

NO. 6930



- > Clamping force: 5,5 - 40 kN
- > cylinder housing: with fine thread

NO. 6932



- > Clamping force: 2,5 - 24,5 kN
- > cylinder housing: with fine thread

NO. 6934



- > Clamping force: 2,4 - 17,5 kN
- > cylinder housing: nitrided, with fine thread

No. 6929-03

Threaded Cylinder for tube connection, with spherical piston rod

single acting, spring return,
max. operating pressure 500 bar,
min. operating pressure 25 bar.

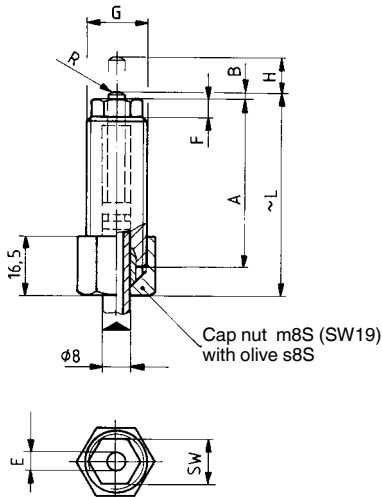
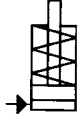

Order no.	Article no.	Push force at 100 bar [kN]	Push force at 500 bar [kN]	Stroke H [mm]	Vol. [cm ³]	Piston dia. [mm]	effective piston area [cm ²]	Spring force min. [N]	Weight [g]
60111	6929-03x10	0,5	2,5	10	0,5	8	0,5	24	80

Design:

As No. 6929, but with cap screw and cutting ring.

Features:

Hoses or tubes can be directly screwed onto the threaded cylinders.

Note:

Pistons of these cylinders must not be loaded in retracted position. Care for protection against aggressive lubricants and coolants. As the cylinder has no stop for the tube, the preassembly of the cutting ring has to be effected by means of a hardened pre-mounting tool. Due to the construction size, an internal stop for the piston is not possible. Therefore, please do not operate the threaded cylinder without workpiece, as the spring could be damaged or its spring force could be reduced.

Dimensions

Order no.	Article no.	A	B	dia. E	F	G	~L	R	SW
60111	6929-03x10	48	1	5	6	M16x1,5	57	6	13

Application examples no. 6929-03:

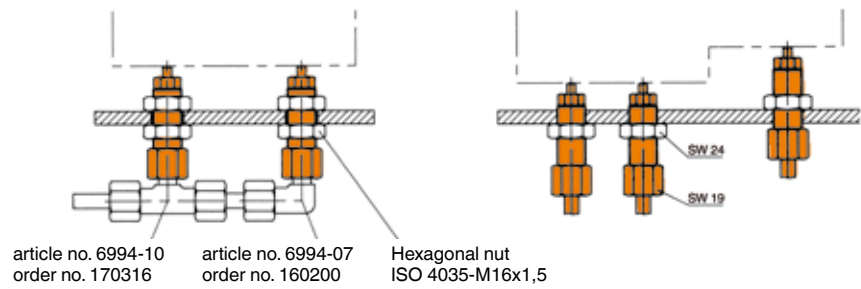

No. 6929

Threaded Cylinder bottom sealing, with spherical piston rod

single acting, spring return, max. operating pressure 500 bar, min. operating pressure 25 bar.

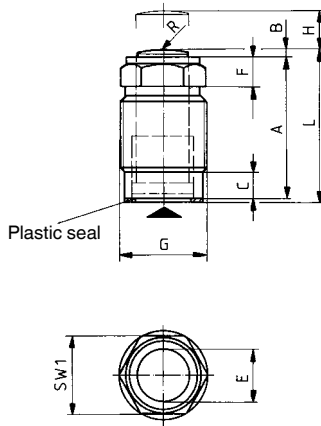

Order no.	Article no.	Push force at 100 bar [kN]	Push force at 500 bar [kN]	Stroke H [mm]	Vol. [cm ³]	Piston dia. [mm]	effective piston area [cm ²]	Md [Nm]	Spring force min. [N]	Weight [g]
60095	6929-02x05	0,5	2,5	5	0,25	8	0,5	10	24	15
60103	6929-02x10	0,5	2,5	10	0,50	8	0,5	10	24	25
60046	6929-05	1,1	5,5	10	1,10	12	1,1	40	45	80
60053	6929-08	2,0	10,0	12	2,40	16	2,0	50	70	140
60061	6929-12	3,0	15,5	15	4,70	20	3,1	60	105	220
60079	6929-20	4,9	24,5	16	7,80	25	4,9	80	145	390
60087	6929-32	8,0	40,0	20	16,00	32	8,0	225	270	930

Design:

Cylinder housing made of steel, blued. Piston and piston rod case-hardened and ground. Wiper on piston rod. Built-in return spring. Attachment with standard fine thread. With plastic washer for bottom sealing. Attachment with fine thread. For no. 6929-02 x 05 and 02 x 10 sealing with Cu-ring.

Application:

These threaded cylinders can be used in all types of clamping fixtures. Ideal for pressure bars for tolerance compensation in multiple-workpiece clamping fixtures, and for positioning, holding or ejecting, and clamping workpieces.

Features:

The cylinders must not be loaded in retracted position. The cylinders must be protected against direct access of lubricants and coolant. The system has to be completely vented during installation.

Note:

Pistons of these cylinders must not be loaded in retracted position. Care for protection against aggressive lubricants and coolants. The sealing surface of the mounting hole to the thread must be at a right angle and even. For sizes 02x05 and 02x10, an internal stop for the piston is not possible due to the construction size. Therefore, do not operate the threaded cylinder without workpiece, as the spring could be damaged or its spring force could be reduced.

Dimensions

Order no.	Article no.	A	B	C	dia. E	F	G	L	P min.	P max.	R	SW1	T max.	U min.	dia. W max.
60095	6929-02x05	27,0	1,0	4	5	4	M12x1,5	29,0	12	23	6	11	-	15	-
60103	6929-02x10	40,0	1,0	4	5	4	M12x1,5	42,0	12	36	6	11	-	15	-
60046	6929-05	35,0	2,0	7	12	6	M22x1,5	38,5	16	29	25	19	8	25	12
60053	6929-08	43,0	2,0	8	16	9	M26x1,5	46,5	20	34	35	24	9	30	16
60061	6929-12	53,0	2,0	8	20	10	M30x1,5	56,5	24	43	50	30	9	38	20
60079	6929-20	55,5	2,5	11	25	12	M38x1,5	60,0	28	44	70	36	11	45	25
60087	6929-32	82,5	2,5	12	32	15	M48x1,5	87,5	42	68	100	46	13	57	30

Application examples no. 6929 and 6930:

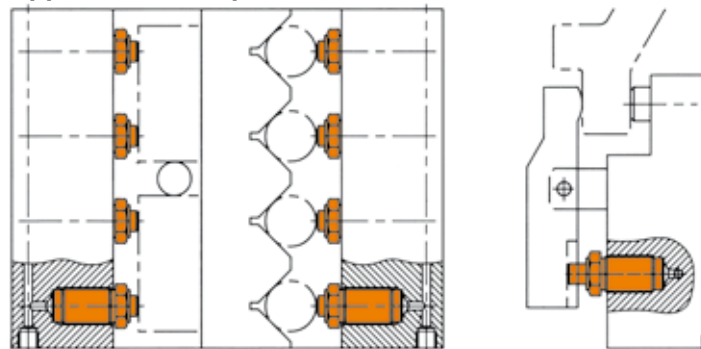

Installation dimensions:

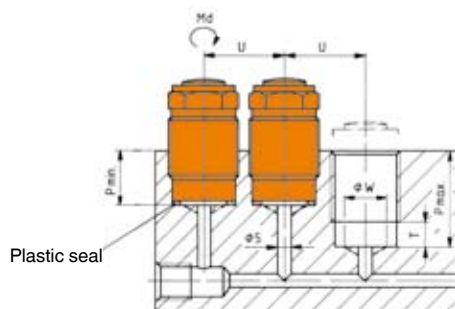

No. 6930

Threaded Cylinder bottom sealing, piston rod with internal thread

single acting, spring return,
max. operating pressure 500 bar,
min. operating pressure 25 bar.

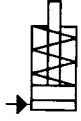

Order no.	Article no.	Push force at 100 bar [kN]	Push force at 500 bar [kN]	Stroke H [mm]	Vol. [cm ³]	Piston dia. [mm]	effective piston area [cm ²]	Md [Nm]	Spring force min. [N]	Weight [g]
60129	6930-05	1,1	5,5	10	1,1	12	1,1	40	45	80
60137	6930-08	2,0	10,0	12	2,4	16	2,0	50	70	140
60145	6930-12	3,0	15,5	15	4,7	20	3,1	60	105	230
60152	6930-20	4,9	24,5	16	7,8	25	4,9	80	145	410
60160	6930-32	8,0	40,0	20	16,0	32	8,0	225	270	970

Design:

Cylinder housing made of steel, blued. Piston and piston rod case-hardened and ground. Wiper on piston rod. Built-in return spring. Attachment with standard fine thread. With plastic washer for bottom sealing. Attachment with fine thread. For no. 6929-02 x 05 and 02 x 10 sealing with Cu-ring.

Application:

These threaded cylinders can be used in all types of clamping fixtures. Ideal for pressure bars for tolerance compensation in multiple-workpiece clamping fixtures, and for positioning, holding or ejecting, and clamping workpieces.

Features:

The cylinders must not be loaded in retracted position. The cylinders must be protected against direct access of lubricants and coolant. The system has to be completely vented during installation.

Note:

Pistons of these cylinders must not be loaded in retracted position. Care for protection against aggressive lubricants and coolants. The sealing surface of the mounting hole to the thread must be at a right angle and even.

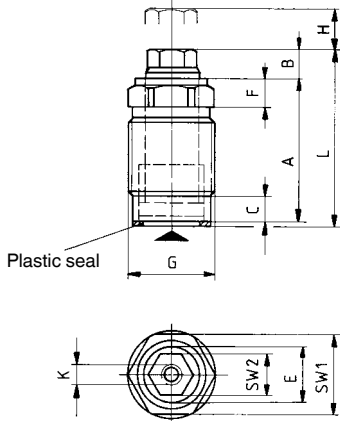

Dimensions

Order no.	Article no.	A	B	C	dia. E	F	G	K x depth	L	P min.	P max.	SW1	SW2	T max.	U min.	dia. W max.
60129	6930-05	35,0	9,0	7	12	6	M22x1,5	M6x6	45,5	16	29	19	10	8	25	12
60137	6930-08	43,0	8,5	8	16	9	M26x1,5	M6x6	53,0	20	34	24	13	9	30	16
60145	6930-12	53,0	11,5	8	20	10	M30x1,5	M8x8	66,0	24	43	30	17	9	38	20
60152	6930-20	55,5	11,5	11	25	12	M38x1,5	M8x8	69,0	28	44	36	19	11	45	25
60160	6930-32	82,5	13,5	12	32	15	M48x1,5	M12x12	98,5	42	68	46	24	13	57	30

No. 6930D

Threaded Cylinder

Double-acting,
max. working pressure 400 bar,
min. operating pressure 25 bar.

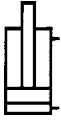

Order no.	Article no.	Push force at 400 bar [kN]	Pull force at 400 bar [kN]	Stroke H ±1 [mm]	Vol. push [cm³]	Vol. pull [cm³]	Piston dia. [mm]	Weight [g]
320507	6930D-05	4,5	2,5	12	1,4	0,8	12	107
320515	6930D-08	8,0	4,9	16	3,2	2,0	16	186
320523	6930D-12	12,0	8,0	20	6,3	4,0	20	270
320531	6930D-20	19,6	11,6	25	12,3	7,3	25	519
320549	6930D-32	32,1	19,6	32	25,7	15,7	32	920
320556	6930D-50	50,2	30,6	40	50,2	30,6	40	1639

Design:

Cylinder housing made of tempering steel, blued. Piston is tempered, ground, nitrided, and treated with a corrosion-resistant coating.

Application:

These threaded cylinders can be used in all types of clamping fixtures. Ideal for pressure bars for tolerance compensation in multiple-workpiece clamping fixtures, and for positioning, holding or ejecting, and clamping workpieces. Can be used extending or retracting.

Features:

The O-rings are smaller than the diameter of the screw-in thread. This reduces the danger of damage to the seal during the installation process.

Two-piece housing makes it easier to change the piston-rod seal. Housing seals against the surface of the hole sleeve. For sizes 05 and 08, there is additional sealing between the housing head and the fixture body.

Small size, can be installed closely spaced side-by-side. The cylinder must be screwed into the fixture body up to its flange. The hydraulic oil can be supplied through a common hole in the fixture body.

Note:

- Maximum speed of operation 0.5 m/s
- Can be supplied on request for higher pressures and temperatures.
- Minimum operating pressure 40 bar.

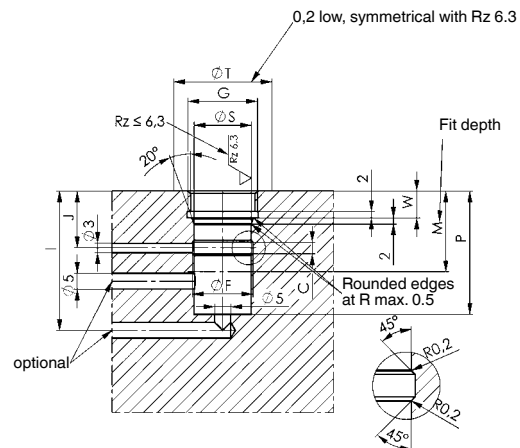
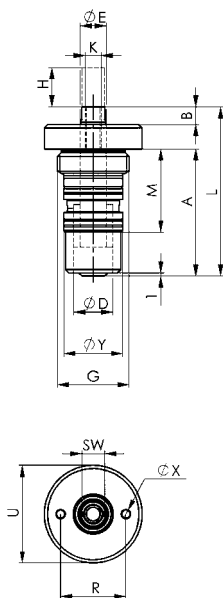

Application example:

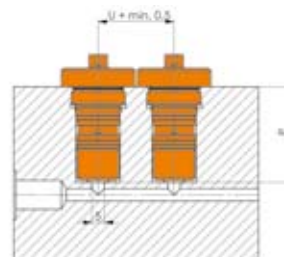

Dimensions

Order no.	Article no.	A	B	C	dia. E F7	F	G	I	J	K x depth	L ±1	M +1	P ±0,2	R	dia. S H7	Min. dia. T	U	W ±0,2	dia. X	dia. Y f7	SW
320507	6930D-05	39	5,5	3,6	8	19,2	M22x1,5	44	18,0	M5x11	52	25,5	39	20	18	31	30	8,5	2,5	18	7
320515	6930D-08	48	6,0	4,0	10	23,0	M26x1,5	53	19,0	M6x14	65	30,0	48	25	22	33	31	8,5	2,5	22	8
320523	6930D-12	53	7,0	4,0	12	29,2	M32x1,5	62	20,0	M8x14	67	31,5	53	30	28	38	37	10,5	4,2	28	10
320531	6930D-20	65	7,0	4,4	16	35,8	M40x1,5	72	25,0	M10x18	82	39,0	65	35	35	45	44	13,5	5,2	35	13
320549	6930D-32	72	10,0	4,4	20	44,8	M50x1,5	79	28,0	M12x18	94	44,0	72	42	44	55	54	15,5	6,2	44	17
320556	6930D-50	86	12,0	5,2	25	56,2	M60x1,5	94	30,5	M16x28	112	47,0	86	50	55	66	65	19,0	6,2	55	24

No. 6932

Threaded Cylinder with spherical piston rod

single acting, spring return,
max. operating pressure 500 bar.

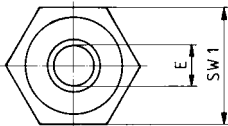
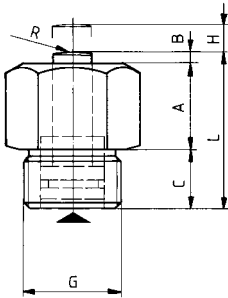
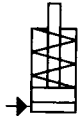

Order no.	Article no.	Push force at 100 bar [kN]	Push force at 500 bar [kN]	Stroke H [mm]	Vol. [cm ³]	Piston dia. [mm]	effective piston area [cm ²]	Md [Nm]	Spring force min. [N]	Weight [g]
60178	6932-02	0,5	2,5	4	0,20	8	0,5	80	25	50
60186	6932-05	1,1	5,5	4	0,45	12	1,1	90	35	80
60194	6932-08	2,0	10,0	6	1,20	16	2,0	110	65	130
60202	6932-12	3,0	15,0	8	2,50	20	3,1	120	100	300
60210	6932-20	5,0	24,5	12	5,90	25	4,9	130	155	470

Design:

Cylinder housing made of steel, blued with hex nut. Piston and piston rod case-hardened and ground. Wiper on piston rod. Built-in return spring. Sinter metal breather. Attachment with standard fine thread. Sealing by sealing edge (see note).

Application:

Ideal for clamping bars for tolerance compensation in multiple fixtures and for positioning, clamping or discharging workpieces.

Features:

The cylinders must not be loaded in retracted position. The cylinders must be protected against direct access of lubricants and coolant. The system has to be completely vented during installation.

Note:

The screw-in cylinders cannot be loaded in the retracted position. For single acting cylinder types, there is a risk of sucking in liquid. The cylinders must be protected against direct penetration of cutting and cooling liquids. The built-in sintered bronze filter should be protected by appropriate arrangement or by a cover. Sealing by sealing edge. For the locating hole, the sealing surface must be at right angles to the thread, flat and not hardened.

Dimensions

Order no.	Article no.	A	B	C	dia. E	G	L	P+1	R	SW1	U min.	dia. Y
60178	6932-02	14	1	12	5	M16x1,5	27	12	10	19	24	23
60186	6932-05	14	1	12	8	M20x1,5	27	12	28	24	30	29
60194	6932-08	21	2	14	10	M24x1,5	37	14	30	27	34	33
60202	6932-12	27	2	18	12	M30x1,5	47	18	36	36	44	43
60210	6932-20	33	2	21	16	M36x1,5	56	21	50	41	50	49

Anwendungsbeispiel:

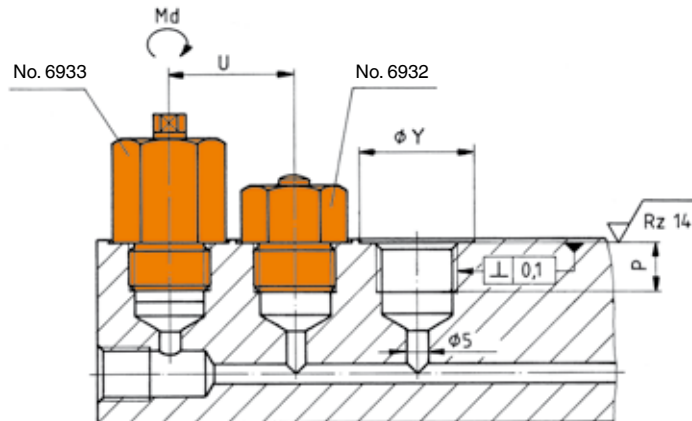

No. 6933

Threaded Cylinder, piston rod with internal thread

single acting, spring return,
max. operating pressure 500 bar.

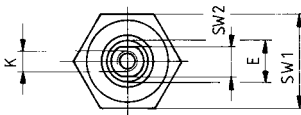
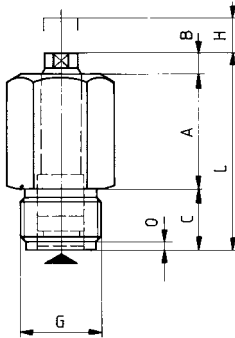
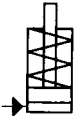

Order no.	Article no.	Push force at 100 bar [kN]	Push force at 500 bar [kN]	Stroke H [mm]	Vol. [cm ³]	Piston dia. [mm]	effective piston area [cm ²]	Md [Nm]	Spring force min. [N]	Weight [g]
60004	6933-05	1,1	5,5	8	0,9	12	1,1	90	35	120
60012	6933-08	2,0	10,0	10	2,0	16	2,0	110	70	200
60020	6933-12	3,0	15,0	10	3,1	20	3,1	120	115	370
60038	6933-20	5,0	24,5	12	5,9	25	4,9	130	160	510
61176	6933-32	8,0	40,0	12	9,6	32	8,0	150	240	750

Design:

Cylinder housing made of steel, blued with hex nut. Piston and piston rod case-hardened and ground. Wiper on piston rod. Built-in return spring. Sinter metal breather. Attachment with standard fine thread. Sealing by sealing edge (see note).

Application:

Ideal for clamping bars for tolerance compensation in multiple fixtures and for positioning, clamping or discharging workpieces.

Features:

The cylinders must not be loaded in retracted position. The cylinders must be protected against direct access of lubricants and coolant. The system has to be completely vented during installation.

Note:

The screw-in cylinders cannot be loaded in the retracted position. For single acting cylinder types, there is a risk of sucking in liquid. The cylinders must be protected against direct penetration of cutting and cooling liquids. The built-in sintered bronze filter should be protected by appropriate arrangement or by a cover. Sealing by sealing edge. For the locating hole, the sealing surface must be at right angles to the thread, flat and not hardened.

Dimensions

Order no.	Article no.	A	B	C	dia. E	G	K x depth	L	O	P +1	SW1	SW2	U min.	dia. Y
60004	6933-05	25	6	15	8	M20x1,5	M4x10	46	3	12	24	6	30	29
60012	6933-08	34	6	18	10	M24x1,5	M5x12	58	3	15	27	8	34	33
60020	6933-12	34	6	21	12	M30x1,5	M6x14	61	3	18	36	9	44	43
60038	6933-20	35	8	23	16	M36x1,5	M8x17	66	3	20	41	13	50	49
61176	6933-32	35	9	25	16	M42x1,5	M8x17	69	3	22	50	13	61	60

No. 6934

Threaded Cylinder bottom sealing

single acting,
max. operating pressure 350 bar.

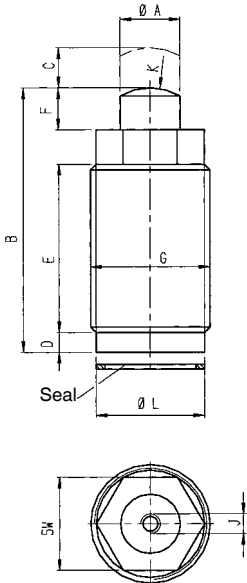

Installation drawing:

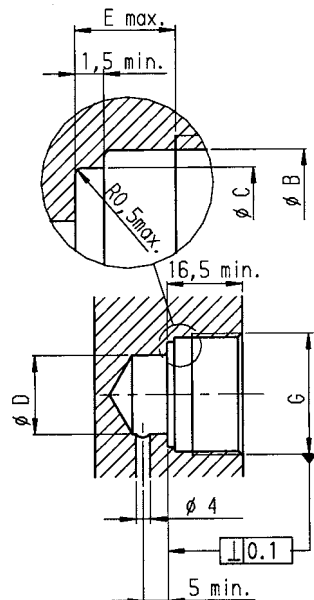

Order no.	Article no.	Push force at 100 bar [kN]	Push force at 350 bar [kN]	Stroke C [mm]	Vol. [cm ³]	Piston area [cm ²]	Md [Nm]	Weight [g]
68312	6934-02	0,68	2,4	5,0	0,3	0,7	40	27
68338	6934-04	1,25	4,4	6,5	0,8	1,3	54	54
68353	6934-10-1	2,88	10,1	9,5	2,7	2,9	68	95
68379	6934-10-2	2,88	10,1	19,0	5,5	2,9	68	191
68395	6934-17	5,00	17,5	8,0	4,0	5,1	50	159

Design:

Cylinder housing made of steel, hardened and blued. Piston and piston rod, case-hardened and ground. piston rod with spherical radius or internal thread. Wiper at piston rod prevents from contamination. Return spring out of stainless steel.

Application:

Threaded cylinders are designed for space saving installation at fixtures. Universal clamping cylinder for clamping, pushing, locking and positioning.

Features:

Small design allows compact arrangements. Manifold mounting eliminates exposed tubing for clean, compact, clutter-free fixtures.

Note:

The cylinders must not be loaded in retracted position. The cylinders must be protected against direct access of lubricants and coolant. The system has to be completely vented during installation.

Dimensions

Order no.	Article no.	A	B	D	E	F	G	SW	J	K	L
68312	6934-02	4,5	28,0	5	17,5	0,5	M16x1,5	13	-	6,5	13,5
68338	6934-04	6,5	37,0	5	25,0	1,5	M20x1,5	16	-	6,5	16,5
68353	6934-10-1	12,5	34,5	8	15,5	1,5	M28x1,5	22	-	19,0	23,0
68379	6934-10-2	12,5	61,5	8	42,5	1,5	M28x1,5	22	M6x11,0	-	23,0
68395	6934-17	16,0	37,5	8	19,0	2,5	M35x1,5	27	M6x12,5	-	31,0

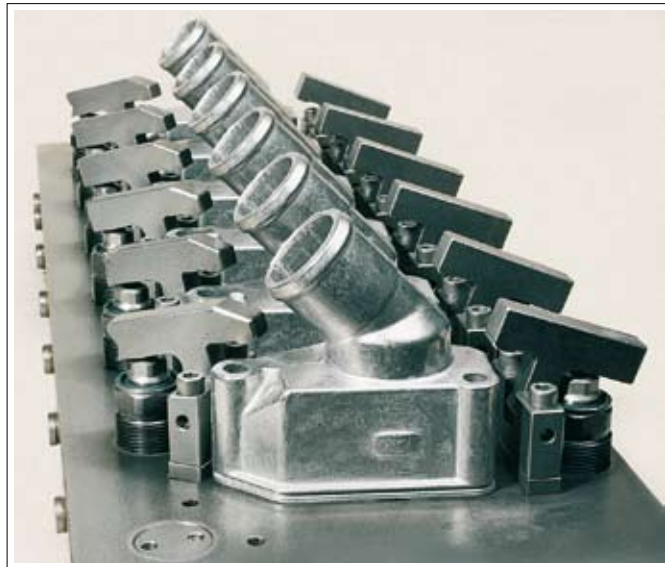

Installation dimensions:

Order no.	Article no.	G	dia. B ±0,15	dia. C ±0,13	dia. D	E
68312	6934-02	M16x1,5	14,5	13,8	8,0	4
68338	6934-04	M20x1,5	18,5	16,8	9,5	4
68353	6934-10-1	M28x1,5	26,5	23,4	16,0	7
68379	6934-10-2	M28x1,5	26,5	23,4	16,0	7
68395	6934-17	M35x1,5	33,5	31,2	22,0	7

Subject to technical alterations.

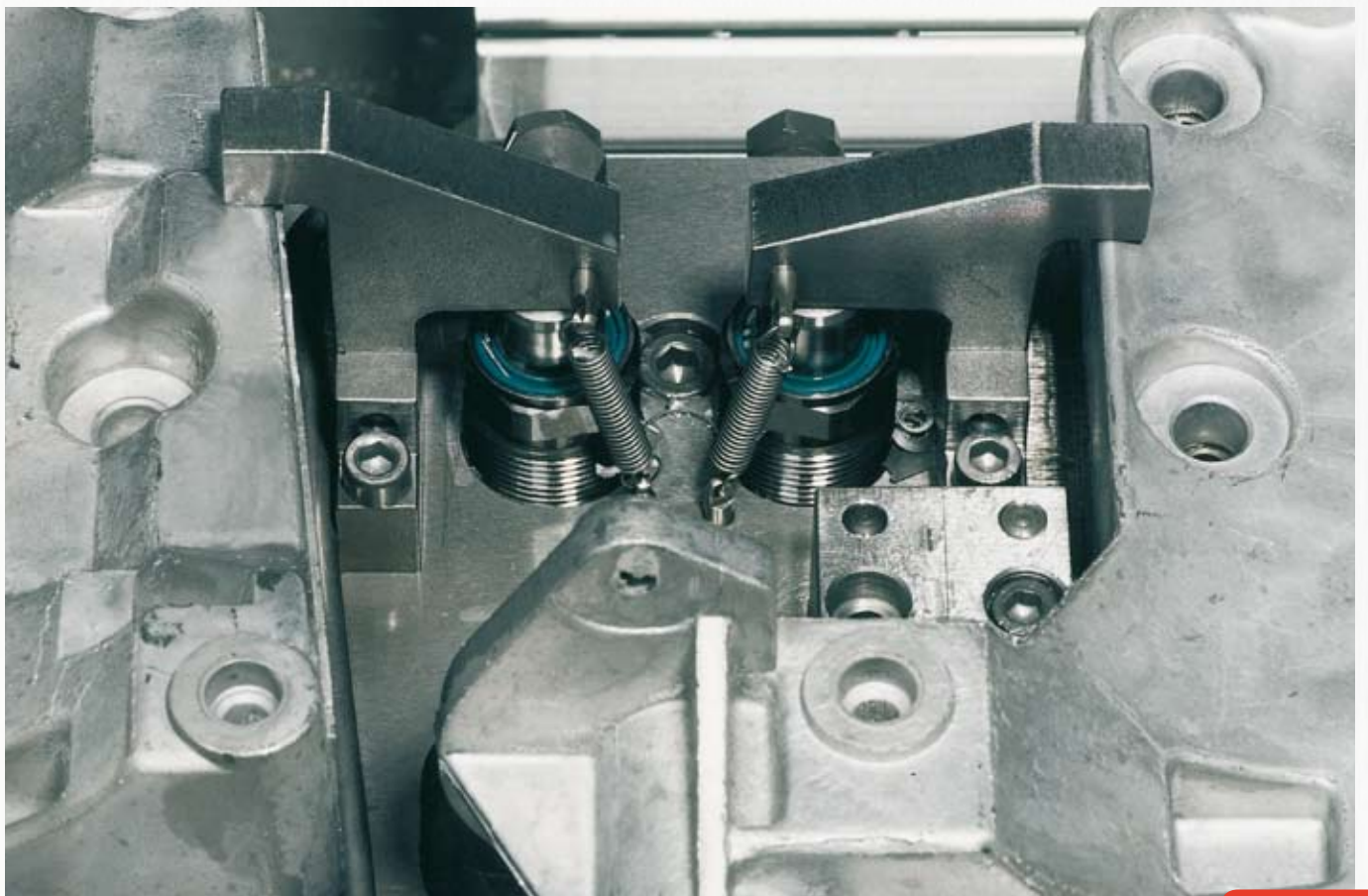
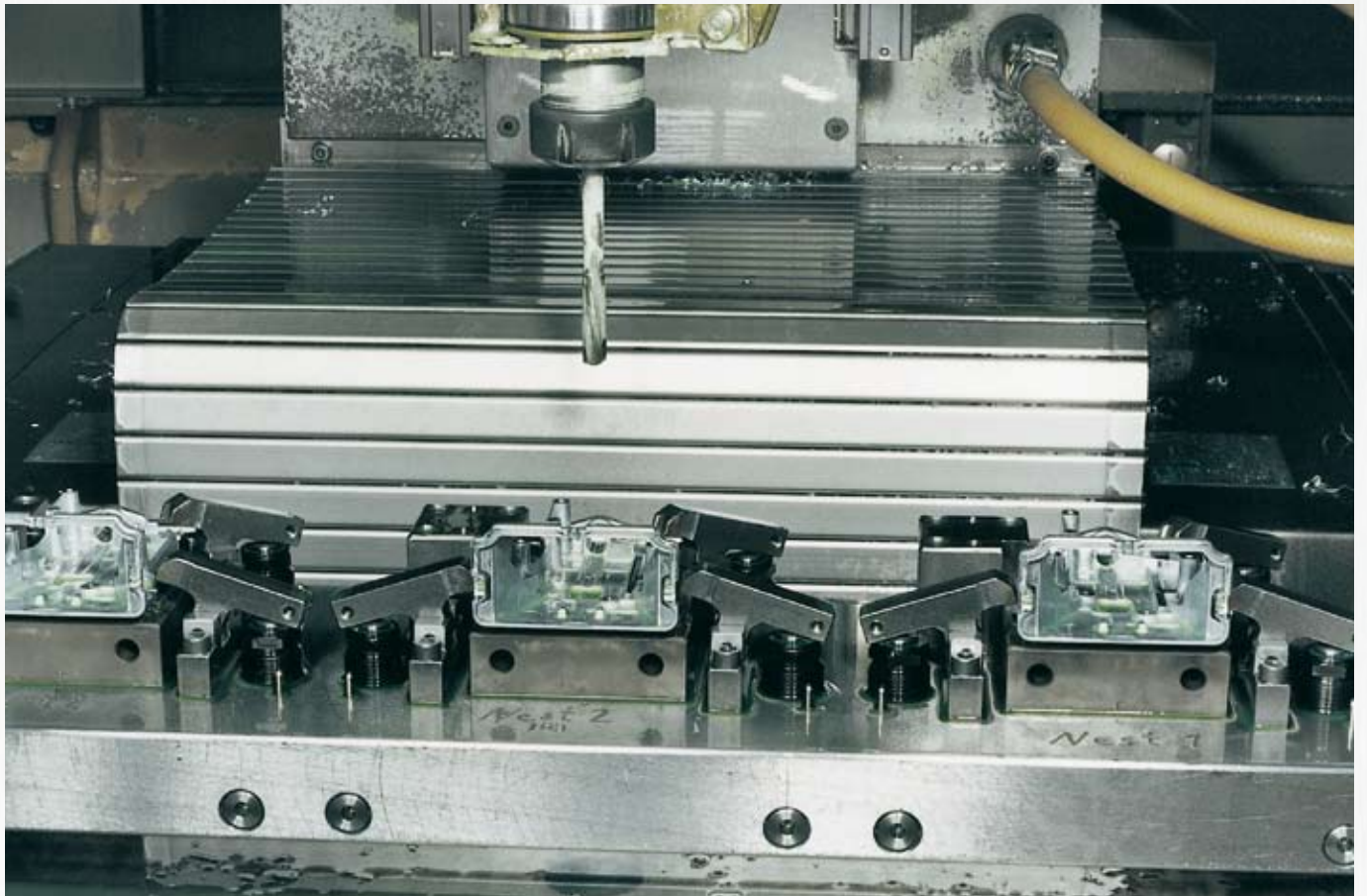

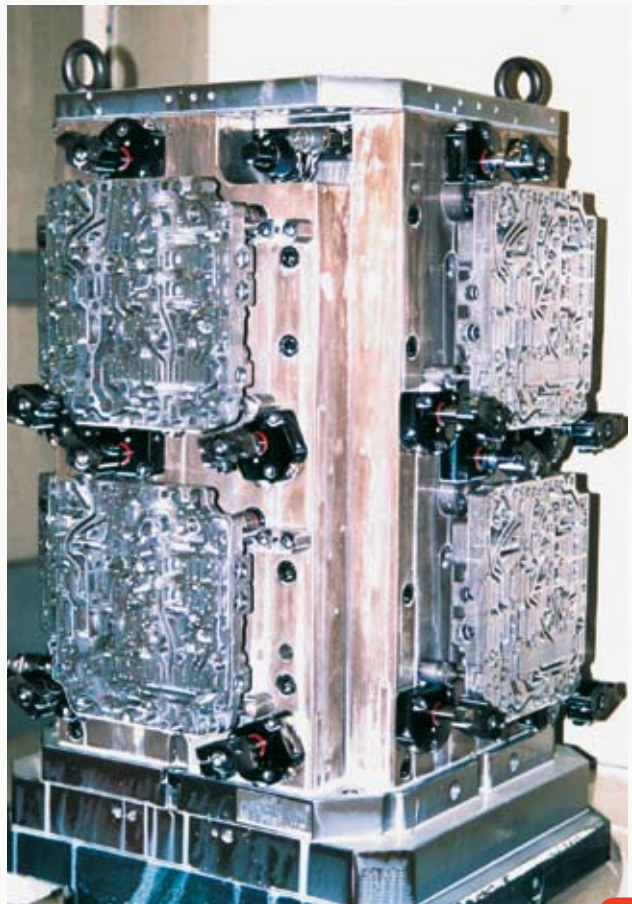
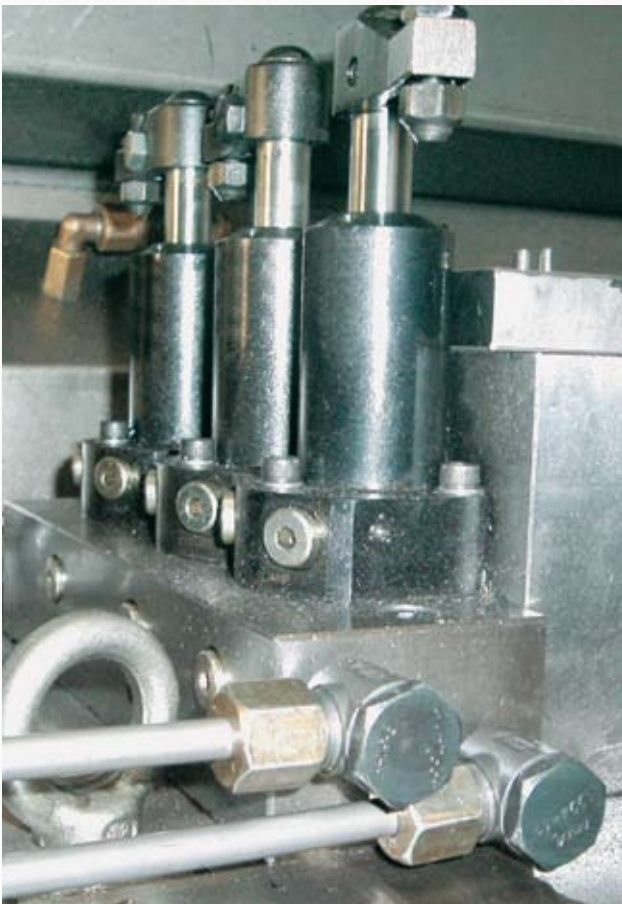
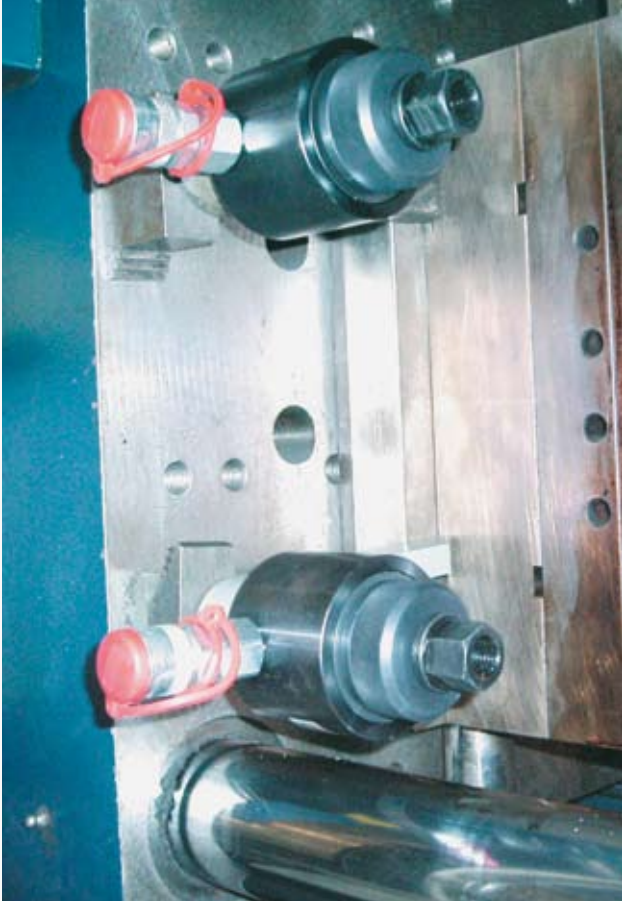

BLOCK CYLINDERS FOR VARIOUS DESIGN APPLICATIONS

- > clamping force up to 155.5 kN
- > operating pressure up to 500 bar
- > piston with internal thread
- > for push- and pull operation
- > with longitudinal and cross bores and perpendicular support groove
- > wipers to protect against contamination
- > single and double-acting variants

PRODUCT OVERVIEW:

Type	Clamping force [kN]	Pull force [kN]	Clamping stroke [mm]	No. of models	Operating mode
6926	10 - 155,5	-	8 - 25	28	single-acting
6926D	10 - 155,5	6 - 93	16 - 50	28	double-acting
6936	10,1 - 39,9	-	6,5 - 51	7	single-acting
6936D	10,1 - 39,9	5,6 - 17,5	6,5 - 51	8	double-acting

PRODUCT EXAMPLES:

NO. 6926



- > Clamping force: 10 - 155,5 kN
- > two mounting versions, two strokes

NO. 6926D



- > Clamping force: 10 - 155,5 kN
- > two mounting versions, two strokes

NO. 6936 / 6936D



- > Clamping force: 10,1 - 39,9 kN
- > two mounting versions, three strokes, nitrided cylinder housing

No. 6926

Block Cylinder

single acting, spring return,
max. operating pressure 500 bar,
min. operating pressure 25 bar.

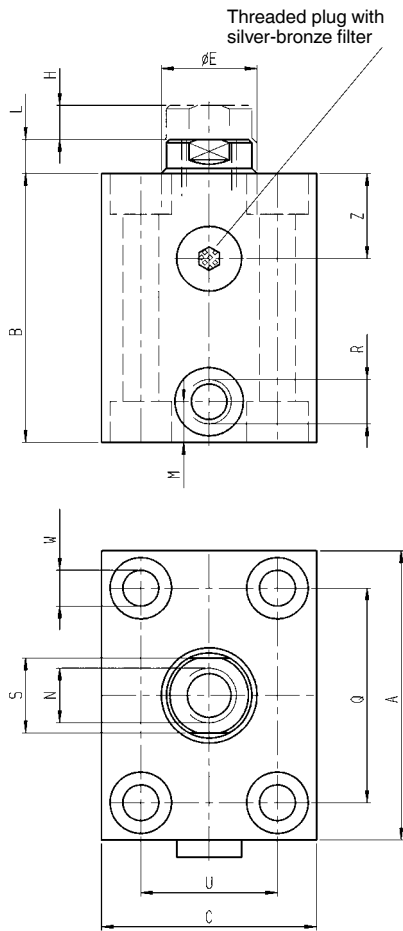
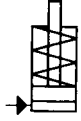

Order no.	Article no.	Push force at 100 bar [kN]	Push force at 500 bar [kN]	Stroke H [mm]	Vol. [cm ³]	Piston dia. [mm]	effective piston area [cm ²]	Spring force min. [N]	Weight [g]
63354	6926-8-001	2,0	10,0	8	1,6	16	2,0	50	840
63362	6926-8-002	2,0	10,0	20	4,0	16	2,0	50	1370
63370	6926-12-001	3,1	15,5	8	2,4	20	3,1	70	920
63388	6926-12-002	3,1	15,5	20	6,2	20	3,1	70	1420
63396	6926-20-001	5,0	25,0	8	4,0	25	5,0	140	1250
63404	6926-20-002	5,0	25,0	20	10,0	25	5,0	140	1870
63412	6926-32-001	8,0	40,0	10	8,0	32	8,0	195	2060
63420	6926-32-002	8,0	40,0	20	16,0	32	8,0	195	2740
63438	6926-50-001	12,5	62,5	10	12,5	40	12,5	270	2830
63446	6926-50-002	12,5	62,5	20	25,0	40	12,5	270	3730
63453	6926-78-001	19,6	98,0	12	23,5	50	19,6	410	4430
63461	6926-78-002	19,6	98,0	20	39,2	50	19,6	410	5670
63479	6926-125-001	31,3	155,5	12	37,3	63	31,1	430	9500
63487	6926-125-002	31,3	155,5	25	77,75	63	31,1	430	9540

Design:

Cylinder housing made of steel, blued. Piston and Piston rod case-hardened and ground. Wiper at piston rod. Piston rod with internal thread.

Features:

Universal mounting by means of mounting holes. Each cylinder size is available with two different strokes.

Note:

For single acting cylinders there is risk of sucking in coolant during return stroke. In this case the sinter metal breather shall be piped to a clean, protected area. Further sizes are available on request. For applications above 160 bar operating pressure, cylinders must be tenon-blocked at slot or being backed up at cylinder body. For fixing screws must be strength class 12.9. All tolerances other than specified refer to DIN ISO 2768 medium.

On request:

Special sizes are available on request.

Dimensions

Order no.	Article no.	A	B	C	dia. E	L	M	N x depth	Q	R	S	U	dia. W	Z
63354	6926-8-001	60	56	35	10	6	11	M6x12	40	G1/4	8	22	6,5	17
63362	6926-8-002	60	91	35	10	6	11	M6x12	40	G1/4	8	22	6,5	17
63370	6926-12-001	60	61	35	14	7	11	M8x15	40	G1/4	10	22	6,5	17
63388	6926-12-002	60	95	35	14	7	11	M8x15	40	G1/4	10	22	6,5	17
63396	6926-20-001	65	64	45	16	7	11	M10x15	50	G1/4	13	30	8,5	18
63404	6926-20-002	65	94	45	16	7	11	M10x15	50	G1/4	13	30	8,5	18
63412	6926-32-001	75	75	55	20	10	11	M12x15	55	G1/4	17	35	10,5	22
63420	6926-32-002	75	100	55	20	10	11	M12x15	55	G1/4	17	35	10,5	22
63438	6926-50-001	85	79	63	25	10	11	M16x25	63	G1/4	22	40	10,5	24
63446	6926-50-002	85	104	63	25	10	11	M16x25	63	G1/4	22	40	10,5	24
63453	6926-78-001	100	90	75	32	10	13	M20x30	76	G1/4	27	45	13,0	27
63461	6926-78-002	100	115	75	32	10	13	M20x30	76	G1/4	27	45	13,0	27
63479	6926-125-001	125	102	95	40	14	17	M27x40	95	G1/4	36	65	17,0	26
63487	6926-125-002	125	122	95	40	14	17	M27x40	95	G1/4	36	65	17,0	26

No. 6926

Block Cylinder

single acting, spring return,
max. operating pressure 500 bar,
min. operating pressure 25 bar.

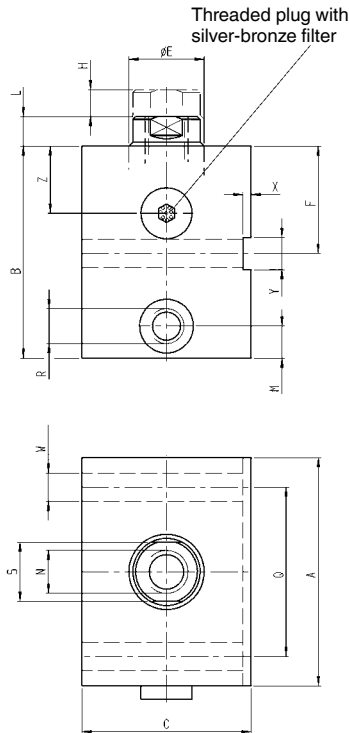

Order no.	Article no.	Push force at 100 bar [kN]	Push force at 500 bar [kN]	Stroke H [mm]	Vol. [cm ³]	Piston dia. [mm]	effective piston area [cm ²]	Spring force min. [N]	Weight [g]
63511	6926-8-003	2,0	10,0	8	1,6	16	2,0	50	900
63529	6926-8-004	2,0	10,0	20	4,0	16	2,0	50	1450
63537	6926-12-003	3,1	15,5	8	2,4	20	3,1	70	980
63545	6926-12-004	3,1	15,5	20	6,2	20	3,1	70	1520
63552	6926-20-003	5,0	25,0	8	4,0	25	5,0	140	1370
63560	6926-20-004	5,0	25,0	20	10,0	25	5,0	140	2030
63578	6926-32-003	8,0	40,0	10	8,0	32	8,0	195	2270
63586	6926-32-004	8,0	40,0	20	16,0	32	8,0	195	3010
63594	6926-50-003	12,5	62,5	10	12,5	40	12,5	270	3040
63602	6926-50-004	12,5	62,5	20	25,0	40	12,5	270	4010
63610	6926-78-003	19,6	98,0	12	23,5	50	19,6	410	4760
63628	6926-78-004	19,6	98,0	20	39,2	50	19,6	410	6080
63636	6926-125-003	31,1	155,5	12	37,3	63	31,1	430	8720
63644	6926-125-004	31,1	155,5	25	77,75	63	31,1	430	10520

Design:

Cylinder housing made of steel, blued. Piston and piston rod case-hardened and ground. Wiper at piston rod. Piston rod with internal thread.

Features:

Universal mounting to fixtures by means of mounting holes. Each cylinder size is available with two different strokes.

Note:

For single acting cylinders there is risk of sucking in coolant during return stroke. In this case the sinter metal breather shall be piped to a clean, protected area. For applications above 160 bar operating pressure, cylinders must be tenon-blocked at slot or being backed up at cylinder body. For fixing screws must be strength class 12.9.

All tolerances other than specified refer to DIN ISO 2768 medium.

On request:

Special sizes are available on request.

Dimensions

Order no.	Article no.	A	B	C	dia. E	F	L	M	N x depth	Q	R	S	dia. W	X	Y	Z
63511	6926-8-003	60	56	35	10	30	6	11	M6x12	40	G1/4	8	6,5	2	8	17
63529	6926-8-004	60	91	35	10	30	6	11	M6x12	40	G1/4	8	6,5	2	8	17
63537	6926-12-003	60	61	35	14	30	7	11	M8x15	40	G1/4	10	6,5	2	8	17
63545	6926-12-004	60	95	35	14	30	7	11	M8x15	40	G1/4	10	6,5	2	8	17
63552	6926-20-003	65	64	45	16	33	7	11	M10x15	50	G1/4	13	8,5	2	10	18
63560	6926-20-004	65	94	45	16	33	7	11	M10x15	50	G1/4	13	8,5	2	10	18
63578	6926-32-003	75	75	55	20	38	10	11	M12x15	55	G1/4	17	10,5	3	12	22
63586	6926-32-004	75	100	55	20	38	10	11	M12x15	55	G1/4	17	10,5	3	12	22
63594	6926-50-003	85	79	63	25	40	10	11	M16x25	63	G1/4	22	10,5	3	12	24
63602	6926-50-004	85	104	63	25	40	10	11	M16x25	63	G1/4	22	10,5	3	12	24
63610	6926-78-003	100	90	75	32	44	10	13	M20x30	76	G1/4	27	13,0	5	16	27
63628	6926-78-004	100	115	75	32	44	10	13	M20x30	76	G1/4	27	13,0	5	16	27
63636	6926-125-003	125	102	95	40	50	14	17	M27x40	95	G1/4	36	17,0	5	20	26
63644	6926-125-004	125	122	95	40	50	14	17	M27x40	95	G1/4	36	17,0	5	20	26

No. 6926D

Block Cylinder

double acting,
max. operating pressure 500 bar,
min. operating pressure 25 bar.

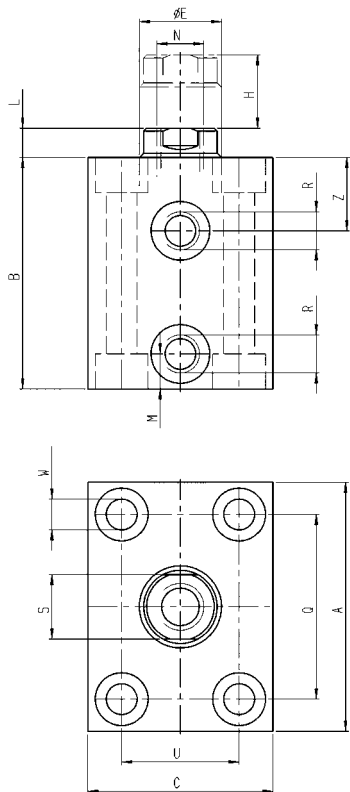
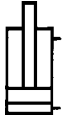

Order no.	Article no.	Push force at 100 bar [kN]	Push force at 500 bar [kN]	Pull force at 100 bar [kN]	Pull force at 500 bar [kN]	Stroke H [mm]	Vol. push [cm ³]	Vol. pull [cm ³]	Piston dia. [mm]	Weight [g]
62034	6926D-8-001	2,0	10,0	1,2	6,0	16	3,2	1,9	16	820
62042	6926D-8-002	2,0	10,0	1,2	6,0	50	10,0	6,0	16	1330
62117	6926D-12-001	3,1	15,5	1,6	8,0	16	5,0	2,6	20	880
62133	6926D-12-002	3,1	15,5	1,6	8,0	50	15,5	8,0	20	1380
62174	6926D-20-001	5,0	25,0	2,9	14,5	20	9,8	5,8	25	1220
62182	6926D-20-002	5,0	25,0	2,9	14,5	50	25,0	14,5	25	1800
62257	6926D-32-001	8,0	40,0	4,9	24,5	25	20,0	12,2	32	1990
62323	6926D-32-002	8,0	40,0	4,9	24,5	50	40,0	24,5	32	2630
62398	6926D-50-001	12,5	62,5	7,6	38,0	25	31,4	19,1	40	2760
62406	6926D-50-002	12,5	62,5	7,6	38,0	50	62,5	38,0	40	3590
62554	6926D-78-001	19,6	98,0	11,6	58,0	25	49,0	29,0	50	4380
62562	6926D-78-002	19,6	98,0	11,6	58,0	50	98,0	58,0	50	5520
62596	6926D-125-001	31,1	155,5	18,6	93,0	30	93,5	55,8	63	7900
62604	6926D-125-002	31,1	155,5	18,6	93,0	50	155,5	93,0	63	9280

Design:

Cylinder housing made of steel, blued. Piston and piston rod case-hardened and ground. Tandem sealing and wiper at piston rod. Piston rod with internal thread.

Features:

Universal mounting by means of mounting holes. Each cylinder size is available with two different strokes.

Note:

For applications above 160 bar operating pressure, cylinders must be tenon-blocked at slot or being backed up at cylinder body. For fixing screws must be strength class 12.9. All tolerances other than specified refer to DIN ISO 2768 medium.

On request:

Special sizes are available on request.

Dimensions

Order no.	Article no.	A	B	C	dia. E	L	M	N x depth	Q	R	S	U	dia. W	Z
62034	6926D-8-001	60	56	35	10	6	11	M6x12	40	G1/4	8	22	6,5	17
62042	6926D-8-002	60	91	35	10	6	11	M6x12	40	G1/4	8	22	6,5	17
62117	6926D-12-001	60	61	35	14	7	11	M8x15	40	G1/4	10	22	6,5	17
62133	6926D-12-002	60	95	35	14	7	11	M8x15	40	G1/4	10	22	6,5	17
62174	6926D-20-001	65	64	45	16	7	11	M10x15	50	G1/4	13	30	8,5	18
62182	6926D-20-002	65	94	45	16	7	11	M10x15	50	G1/4	13	30	8,5	18
62257	6926D-32-001	75	75	55	20	10	11	M12x15	55	G1/4	17	35	10,5	22
62323	6926D-32-002	75	100	55	20	10	11	M12x15	55	G1/4	17	35	10,5	22
62398	6926D-50-001	85	79	63	25	10	11	M16x25	63	G1/4	22	40	10,5	24
62406	6926D-50-002	85	104	63	25	10	11	M16x25	63	G1/4	22	40	10,5	24
62554	6926D-78-001	100	90	75	32	10	13	M20x30	76	G1/4	27	45	13,0	27
62562	6926D-78-002	100	115	75	32	10	13	M20x30	76	G1/4	27	45	13,0	27
62596	6926D-125-001	125	102	95	40	14	17	M27x40	95	G1/4	36	65	17,0	26
62604	6926D-125-002	125	122	95	40	14	17	M27x40	95	G1/4	36	65	17,0	26

No. 6926D

Special block cylinders

double acting.

Order no.	Article no.	Push force at 100 bar [kN]	Push force at 500 bar [kN]	Stroke [mm]	Vol. push [cm ³]	Vol. pull [cm ³]	Piston dia. [mm]	Piston area push [cm ²]	Piston area pull [cm ²]	Weight [g]
295410	6926D-8-200	2,0	10,0	100	20	12	16	2,0	1,2	2200
295436	6926D-12-200	3,1	15,5	100	31	20	20	3,1	1,6	2300
295451	6926D-20-200	5,0	25,0	100	50	29	25	4,9	2,9	3100
295477	6926D-32-200	8,0	40,0	100	80	49	32	8,0	4,9	4500
283184	6926D-50-200	12,5	62,5	100	125	76	40	12,5	7,6	5800
294637	6926D-78-200	19,6	98,0	100	196	116	50	19,6	11,6	8500
295535	6926D-125-200	31,1	155,0	100	311	186	63	31,1	18,6	14500
295550	6926D-200-001	50,3	251,0	32	160	98	80	50,3	30,5	15000
295360	6926D-200-002	50,3	251	80	402	245	80	50,3	30,5	21000
295592	6926D-200-200	50,3	251,0	100	503	305	80	50,3	30,5	24000

No. 6926D

Block Cylinder

double acting,
max. operating pressure 500 bar,
min. operating pressure 25 bar.

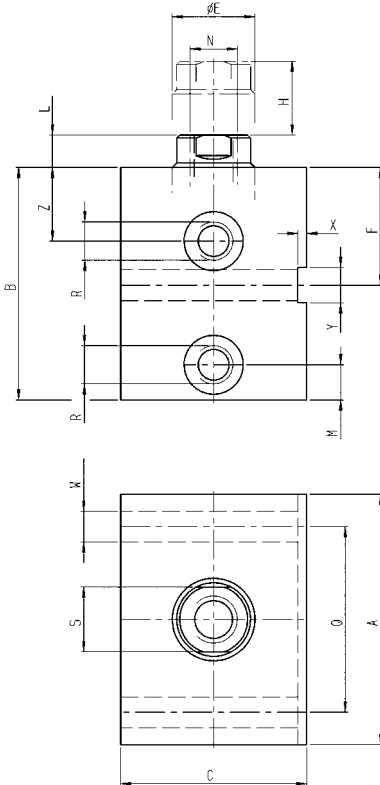

Order no.	Article no.	Push force at 100 bar [kN]	Push force at 500 bar [kN]	Pull force at 100 bar [kN]	Pull force at 500 bar [kN]	Stroke H [mm]	Vol. push [cm ³]	Vol. pull [cm ³]	Piston dia. [mm]	Weight [g]
62067	6926D-8-003	2,0	10,0	1,2	6,0	16	3,2	1,9	16	880
62091	6926D-8-004	2,0	10,0	1,2	6,0	50	10,0	6,0	16	1420
62158	6926D-12-003	3,1	15,5	1,6	8,0	16	5,0	3,2	20	950
62166	6926D-12-004	3,1	15,5	1,6	8,0	50	15,5	10,0	20	1470
62190	6926D-20-003	5,0	25,0	2,9	14,5	20	9,8	5,8	25	1340
62208	6926D-20-004	5,0	25,0	2,9	14,5	50	25,0	14,5	25	1980
62372	6926D-32-003	8,0	40,0	4,9	24,5	25	20,0	12,2	32	2200
62380	6926D-32-004	8,0	40,0	4,9	24,5	50	40,0	24,5	32	2910
62455	6926D-50-003	12,5	62,5	7,6	38,0	25	31,4	19,1	40	2970
62463	6926D-50-004	12,5	62,5	7,6	38,0	50	62,5	38,0	40	3860
62570	6926D-78-003	19,6	98,0	11,6	58,0	25	49,0	29,0	50	4700
62588	6926D-78-004	19,6	98,0	11,6	58,0	50	98,0	58,0	50	5940
62653	6926D-125-003	31,1	155,5	18,6	93,0	30	93,5	55,8	63	8440
62786	6926D-125-004	31,1	155,5	18,6	93,0	50	155,5	93,0	63	10010

Design:

Cylinder housing made of steel, hardened and blued. Piston and piston rod case-hardened and ground. Tandem sealing and wiper at piston rod. Piston rod with internal thread.

Features:

Universal mounting by means of mounting holes. Each cylinder size is available with two different strokes.

Note:

The block cylinders are designed with slots for keys. For applications above 160 bar operating pressure, cylinders must be tenon-blocked at slot or being backed up at cylinder body. For fixing screws must be strength class 12.9. All tolerances other than specified refer to DIN ISO 2768 medium.

On request:

Special sizes are available on request.

Dimensions

Order no.	Article no.	A	B	C	dia. E	F	L	M	N x depth	Q	R	S	dia. W	X	Y	Z
62067	6926D-8-003	60	56	35	10	30	6	11	M6x12	40	G1/4	8	6,5	2	8	17
62091	6926D-8-004	60	91	35	10	30	6	11	M6x12	40	G1/4	8	6,5	2	8	17
62158	6926D-12-003	60	61	35	14	30	7	11	M8x15	40	G1/4	10	6,5	2	8	17
62166	6926D-12-004	60	95	35	14	30	7	11	M8x15	40	G1/4	10	6,5	2	8	17
62190	6926D-20-003	65	64	45	16	33	7	11	M10x15	50	G1/4	13	8,5	2	10	18
62208	6926D-20-004	65	94	45	16	33	7	11	M10x15	50	G1/4	13	8,5	2	10	18
62372	6926D-32-003	75	75	55	20	38	10	11	M12x15	55	G1/4	17	10,5	3	12	22
62380	6926D-32-004	75	100	55	20	38	10	11	M12x15	55	G1/4	17	10,5	3	12	22
62455	6926D-50-003	85	79	63	25	40	10	11	M16x25	63	G1/4	22	10,5	3	12	24
62463	6926D-50-004	85	104	63	25	40	10	11	M16x25	63	G1/4	22	10,5	3	12	24
62570	6926D-78-003	100	90	75	32	44	10	13	M20x30	76	G1/4	27	13,0	5	16	27
62588	6926D-78-004	100	115	75	32	44	10	13	M20x30	76	G1/4	27	13,0	5	16	27
62653	6926D-125-003	125	102	95	40	50	14	17	M27x40	95	G1/4	36	17,0	5	20	26
62786	6926D-125-004	125	122	95	40	50	14	17	M27x40	95	G1/4	36	17,0	5	20	26

No. 6926D

Special block cylinders

double acting.

Order no.	Article no.	Push force at 100 bar [kN]	Push force at 500 bar [kN]	Stroke [mm]	Vol. push [cm ³]	Vol. pull [cm ³]	Piston dia. [mm]	Piston area push [cm ²]	Piston area pull [cm ²]	Weight [g]
295618	6926D-8-400	2,0	10,0	100	20	12	16	2,0	1,2	2200
295626	6926D-12-400	3,1	15,5	100	31	20	20	3,1	1,6	2300
295634	6926D-20-400	5,0	25,0	100	50	29	25	4,9	2,9	3100
295642	6926D-32-400	8,0	40,0	100	80	49	32	8,0	4,9	4500
295246	6926D-50-400	12,5	62,5	100	125	76	40	12,5	7,6	5800
295667	6926D-78-400	19,6	98,0	100	196	116	50	19,6	11,6	8500
295675	6926D-125-400	31,1	155,0	100	311	186	63	31,1	18,6	14500
295683	6926D-200-003	50,3	251,0	32	160	98	80	50,3	30,5	15000
295691	6926D-200-004	50,3	251,0	80	402	245	80	50,3	30,5	21000
295709	6926D-200-400	50,3	251,0	100	503	305	80	50,3	30,5	24000

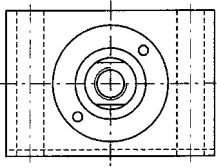
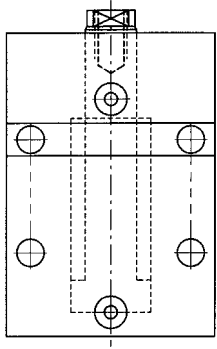

CONNECTIONS IN SIDE FACE

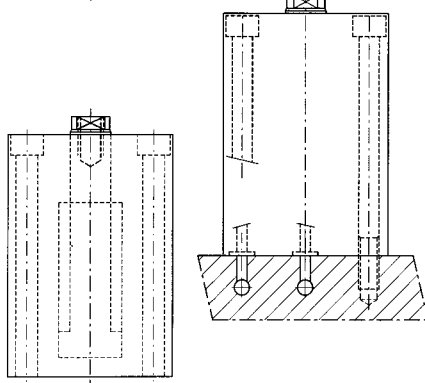
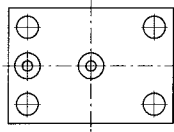

CONNECTIONS IN BASE

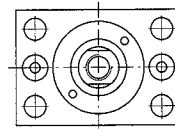
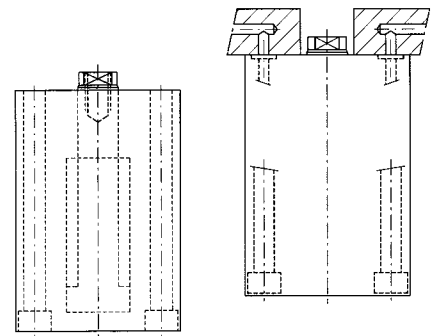

CONNECTIONS IN PISTON-ROD FACE

Block cylinders with O-ring connection are available in special-purpose versions upon request. Thanks to their extensive force range, compact design and short and precise cycle times, block cylinders are an ideal solution for innumerable applications.

APPLICATIONS:

- > positioning
- > clamping
- > coining
- > blanking
- > riveting
- > gripping
- > closing
- > opening
- > bending
- > pulling

INDUSTRIES:

- > automotive
- > machine-tools
- > tool-making
- > mould-making
- > injection moulding

FEATURES AND VARIANTS:

- > 500 bar max. operating pressure
- > 8 to 200 mm stroke
- > 1000 kN force range
- > any installation position

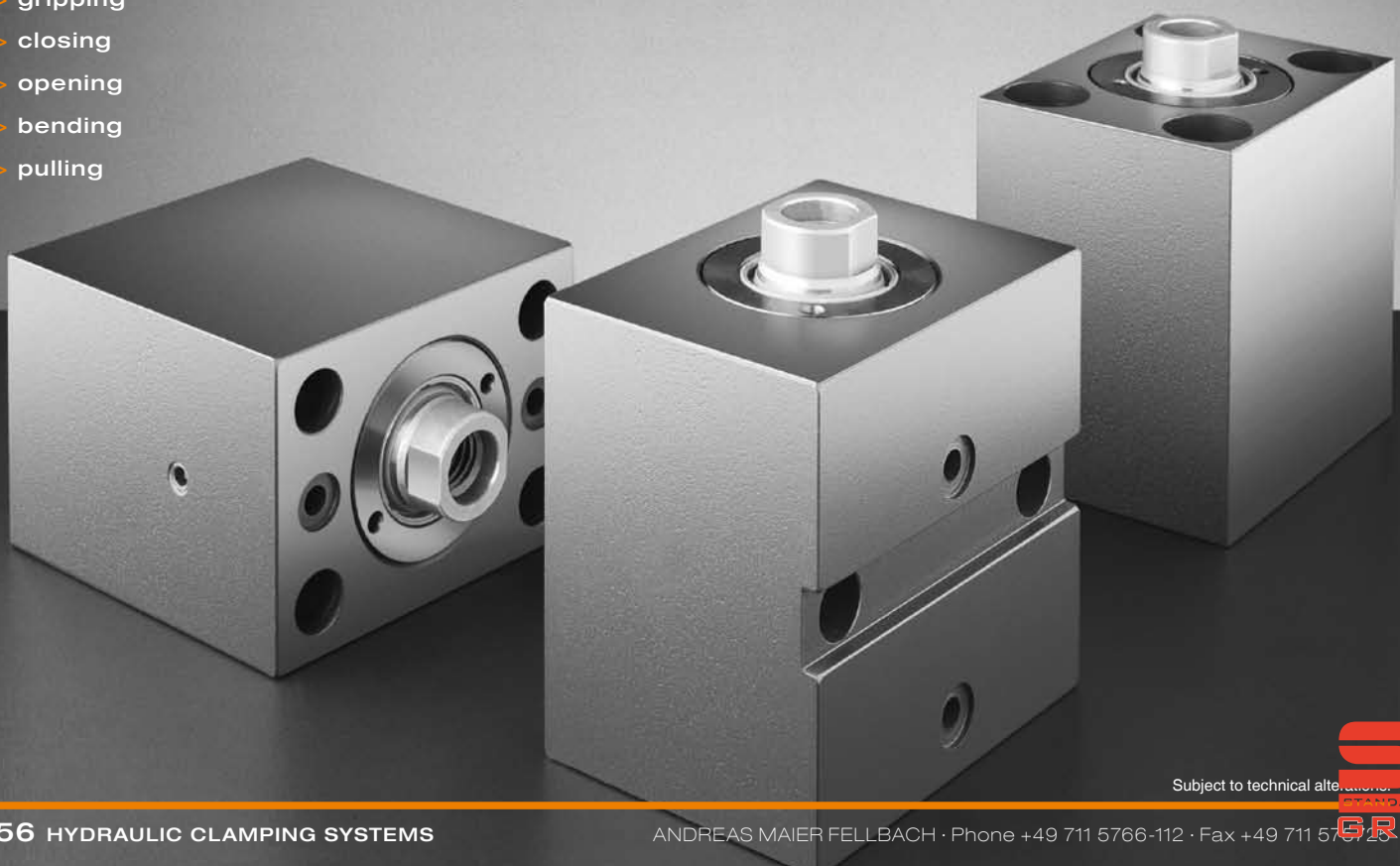

Subject to technical alterations.

Available upon request. Block cylinders with O-ring- or threaded connection as special variant, double-acting, aluminium housing. With individually-adjustable magnetic sensors for position monitoring, and transverse or axial mounting holes.

Block cylinders with position monitoring are used for clamping and releasing tasks and in automatic plant and production operations where they must be integrated into a cycle. The current piston position is detected by magnetic sensors which are mounted in an axial slot for easy adjustment.

FEATURES:

Maximum operating pressure 350 bar, 20 mm to 100 mm stroke. Case-hardened steel piston. Compact size, individual connections and mountings are possible.

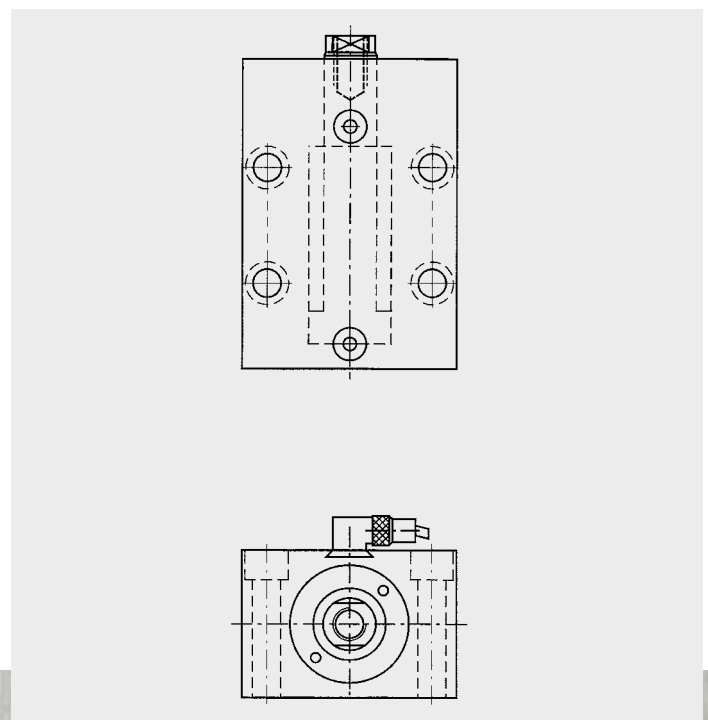
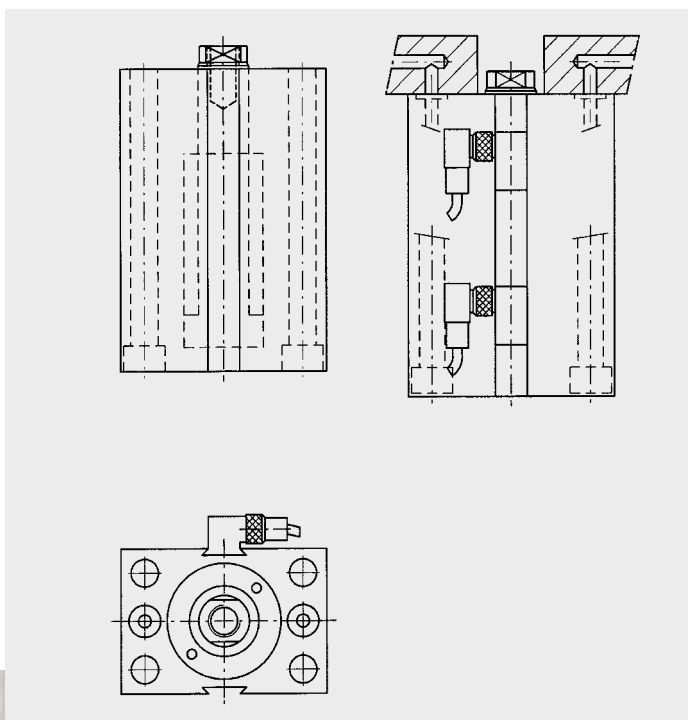
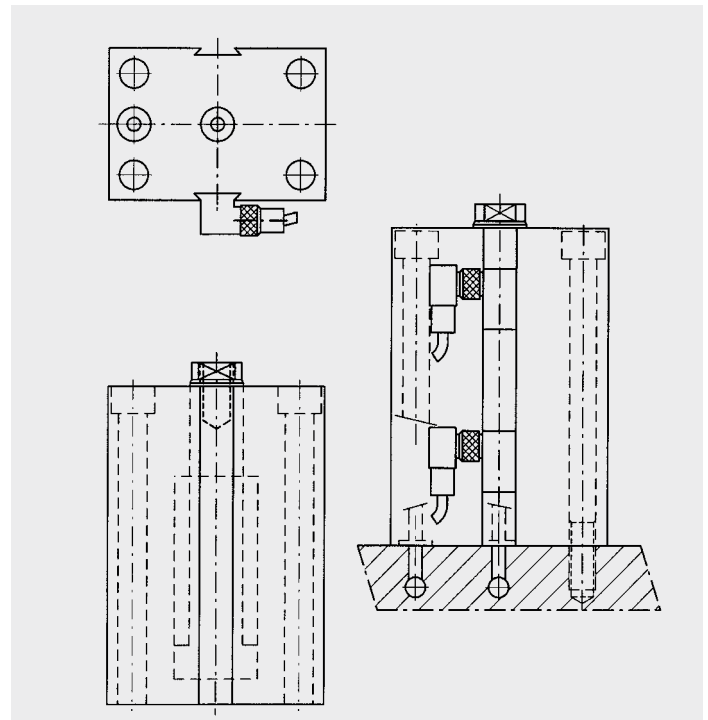
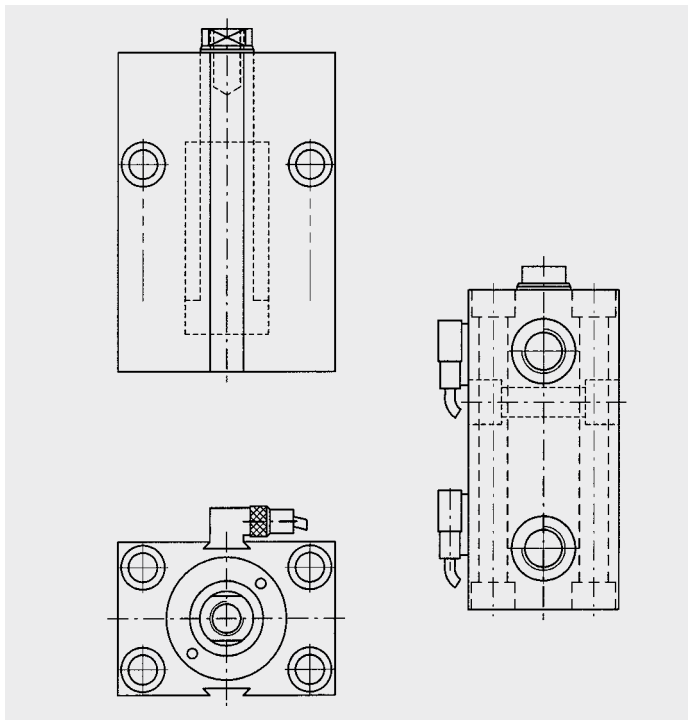

No. 6936

Block Cylinder

single acting,
max. operating pressure 350 bar.

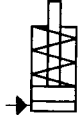

Order no.	Article no.	Push force at 100 bar [kN]	Push force at 350 bar [kN]	Stroke B [mm]	Vol. [cm ³]	Piston area [cm ²]	Weight [g]
68023	6936-10-1	2,88	10,1	6,5	1,9	2,9	463
68049	6936-10-2	2,88	10,1	19,0	5,7	2,9	653
68056	6936-18-1	5,08	17,8	12,5	6,5	5,1	880
68072	6936-18-2	5,08	17,8	25,5	13,0	5,1	1061
68098	6936-18-3	5,08	17,8	51,0	26,0	5,1	1442
68114	6936-40-1	11,40	39,9	12,5	14,5	11,4	1270
68130	6936-40-2	11,40	39,9	25,5	29,0	11,4	1506

Design:

Cylinder housing made of steel, hardened and blued. Piston and piston rod with internal thread, case-hardened and ground. Wiper at piston rod prevents from contamination. Return spring out of stainless steel.

Application:

Universal mounting. Universal block cylinder for e.g. clamping, pushing, locking, rivetting.

Features:

Different strokes are available for each cylinder size. Every model is furnished with parallel and perpendicular mounting holes. Tapped piston rod ends allow the use of custom end attachments.

Note:

For single acting cylinders there is risk of sucking in coolant through the breather port. In such cases the breather port has to be piped to a clean protected area. The system has to be completely vented during installation. For applications above 160 bar operating pressure, cylinders must be tenon-blocked at slot or being backed up at cylinder body. For fixing screws must be strength class 12.9.

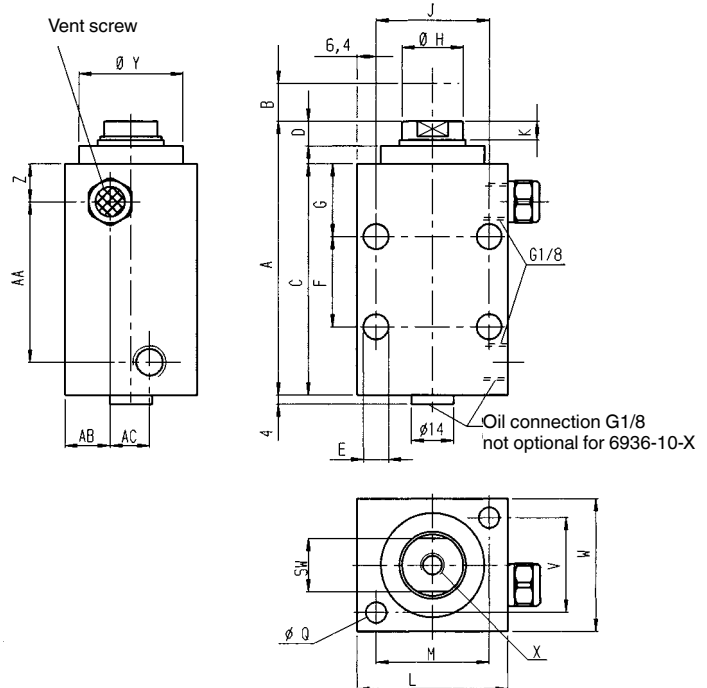

Dimensions

Order no.	Article no.	A	B	C	D	E	F	G	H	J	K	L	M	Q	SW	V	W	X	Y	Z	AA	AB	AC
68023	6936-10-1	60,0	6,5	46,5	7,5	7	-	23,5	12,2	33,5	5,5	51,0	33,5	7	11	16,0	28,5	M6x11	27,0	9,5	28,0	9,5	-
68049	6936-10-2	79,0	19,0	66,0	7,5	7	-	23,5	12,2	33,5	5,5	51,0	33,5	7	11	16,0	28,5	M6x11	27,0	9,5	47,0	9,5	-
68056	6936-18-1	71,0	12,5	57,0	8,0	9	-	26,5	20,1	38,0	6,5	51,0	38,0	7	17	32,0	44,5	M8x11	35,0	12,5	28,5	8,0	14,5
68072	6936-18-2	84,0	25,5	69,5	8,0	9	-	26,5	20,1	38,0	6,5	51,0	38,0	7	17	32,0	44,5	M8x11	35,0	12,5	41,0	8,0	14,5
68098	6936-18-3	112,5	51,0	98,5	8,0	9	41	26,5	20,1	38,0	6,5	51,0	38,0	7	17	32,0	44,5	M8x11	35,0	12,5	70,0	8,0	14,5
68114	6936-40-1	73,0	12,5	57,0	10,0	9	-	26,5	28,2	51,0	9,0	63,5	48,0	9	25	35,5	51,0	M12x13	44,5	12,5	28,5	8,0	17,5
68130	6936-40-2	86,0	25,5	69,5	10,0	9	-	26,5	28,2	51,0	9,0	63,5	48,0	9	25	35,5	51,0	M12x13	44,5	12,5	41,0	8,0	17,5

No. 6936D

Block Cylinder

double acting,
max. operating pressure 350 bar.



Order no.	Article no.	Push force at 100 bar [kN]	Push force at 350 bar [kN]	Pull force at 100 bar [kN]	Pull force at 350 bar [kN]	Stroke B [mm]	Vol. work stroke [cm³]	Piston area work stroke [cm²]	Piston area back stroke [cm²]	Weight [g]
68155	6936D-10-1	2,9	10,1	1,6	5,6	6,5	1,9	2,9	1,6	467
68171	6936D-10-2	2,9	10,1	1,6	5,6	19,0	5,7	2,9	1,6	644
68197	6936D-18-1	5,1	17,8	1,7	6,0	12,5	6,5	5,1	1,7	463
68213	6936D-18-2	5,1	17,8	1,7	6,0	25,5	13,0	5,1	1,7	1030
68239	6936D-18-3	5,1	17,8	1,7	6,0	51,0	26,0	5,1	1,7	1397
68254	6936D-40-1	11,4	39,9	5,0	17,5	12,5	14,5	11,4	5,0	1225
68270	6936D-40-2	11,4	39,9	5,0	17,5	25,5	29,0	11,4	5,0	1447
68296	6936D-40-3	11,4	39,9	5,0	17,5	51,0	58,0	11,4	5,0	1851

Design:

Cylinder housing made of steel, hardened and blued. Piston and piston rod with internal thread, case-hardened and ground. Wiper at piston rod prevents from contamination.

Application:

Universal mounting to equipment using mounting holes. Universal element clamping, pressurising, riveting and punching.

Features:

Different strokes are available for each cylinder size. Every model is furnished with parallel and perpendicular mounting holes. Tapped piston rod ends allow the use of custom end attachments.

Note:

The system has to be completely vented during installation. For applications above 160 bar operating pressure, cylinders must be tenon-blocked at slot or being backed up at cylinder body. For fixing screws must be strength class 12.9.

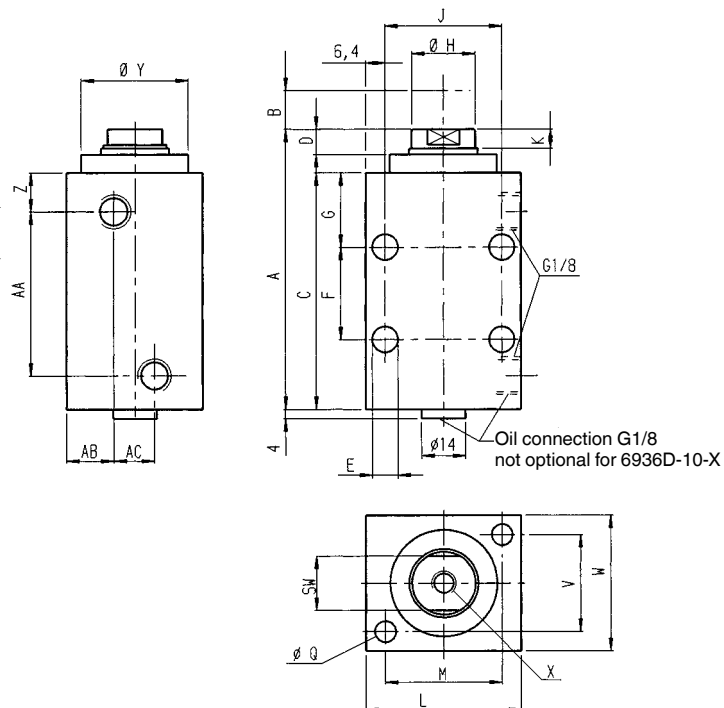

Dimensions

Order no.	Article no.	A	B	C	D	E	F	G	H	J	K	L	M	Q	SW	V	W	X	Y	Z	AA	AB	AC
68155	6936D-10-1	60,0	6,5	46,5	7,5	7	-	23,5	12,2	33,5	5,5	51,0	33,5	7	11	16,0	28,5	M6x11	27,0	9,5	28,0	9,5	-
68171	6936D-10-2	79,0	19,0	66,0	7,5	7	-	23,5	12,2	33,5	5,5	51,0	33,5	7	11	16,0	28,5	M6x11	27,0	9,5	47,0	9,5	-
68197	6936D-18-1	71,0	71,0	57,0	8,0	9	-	26,5	20,1	38,0	6,5	51,0	38,0	7	17	32,0	44,5	M8x11	35,0	12,5	28,5	8,0	14,5
68213	6936D-18-2	84,0	84,0	69,5	8,0	9	-	26,5	20,1	38,0	6,5	51,0	38,0	7	17	32,0	44,5	M8x11	35,0	12,5	41,0	8,0	14,5
68239	6936D-18-3	112,5	112,5	98,5	8,0	9	41	26,5	20,1	38,0	6,5	51,0	38,0	7	17	32,0	44,5	M8x11	35,0	12,5	70,0	8,0	14,5
68254	6936D-40-1	73,0	73,0	57,0	10,0	9	-	26,5	28,2	51,0	9,0	63,5	48,0	9	25	35,5	51,0	M12x13	44,5	12,5	28,5	8,0	17,5
68270	6936D-40-2	86,0	86,0	69,5	10,0	9	-	26,5	28,2	51,0	9,0	63,5	48,0	9	25	35,5	51,0	M12x13	44,5	12,5	41,0	8,0	17,5
68296	6936D-40-3	114,5	51,0	98,5	10,0	9	41	26,5	28,2	51,0	9,0	63,5	48,0	9	25	35,5	51,0	M12x13	44,5	12,5	70,0	8,0	17,5

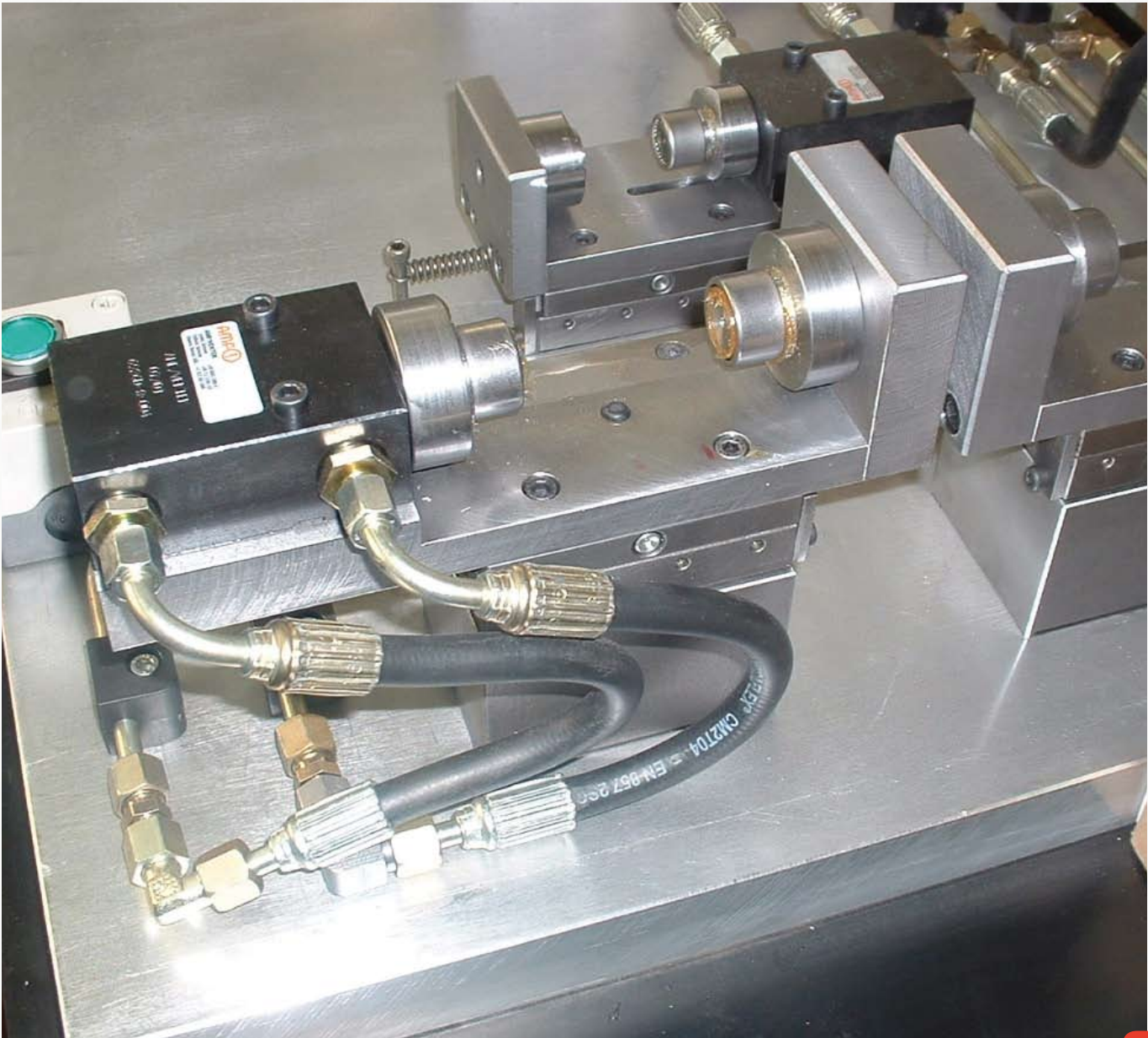
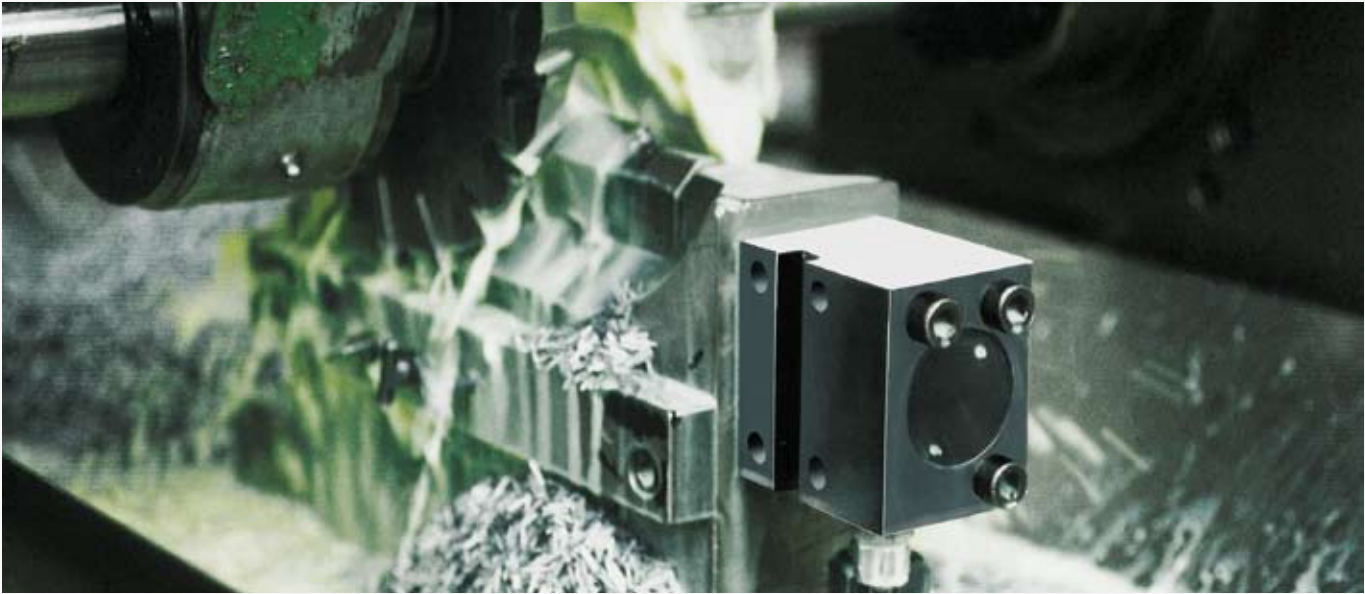

No. 6926Z

Hook ends, hydraulic

max. operating pressure 250 bar.



Order no.	Article no.	Slot	G	H1 Stroke	R	max. possible clamping force [kN]	Weight [g]
325373	6926Z-12	14, 16, 18	M12	8	G1/4	15	1430
325399	6926Z-16	18, 20, 22, 24	M16	10	G1/4	40	3650

Application:

For tensioning primarily cylindrical parts - on both the machine table and clamping plates. The chain length and clamping force are preset on the counter catch using knurled nuts. The hook end is then placed under hydraulic pressure to tension the chain.

Advantage:

Even pressure distribution reduces workpiece deformation.

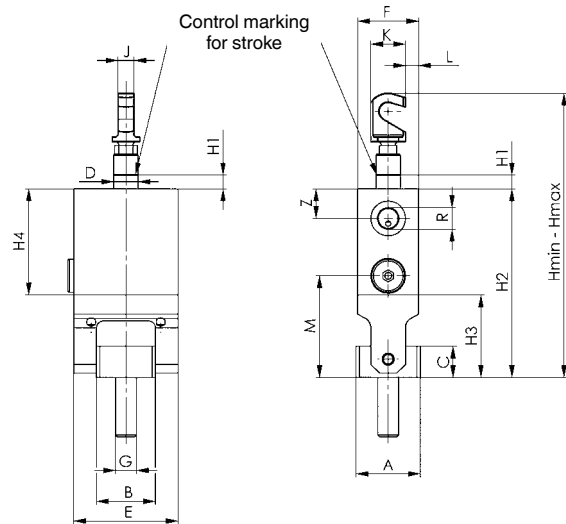

Dimensions

Order no.	Article no.	A	B	C	D	E	F	H min.	H max.	H2	H3	H4	J	K	L	M	Z
325373	6926Z-12	37	34	18	14	60	35	155,5	163,5	108,5	47,5	61	9	20,0	7,5	58,5	17
325399	6926Z-16	37	44	25	20	75	55	185,0	195,0	134,0	59,0	75	16	22,5	21,0	70,0	22

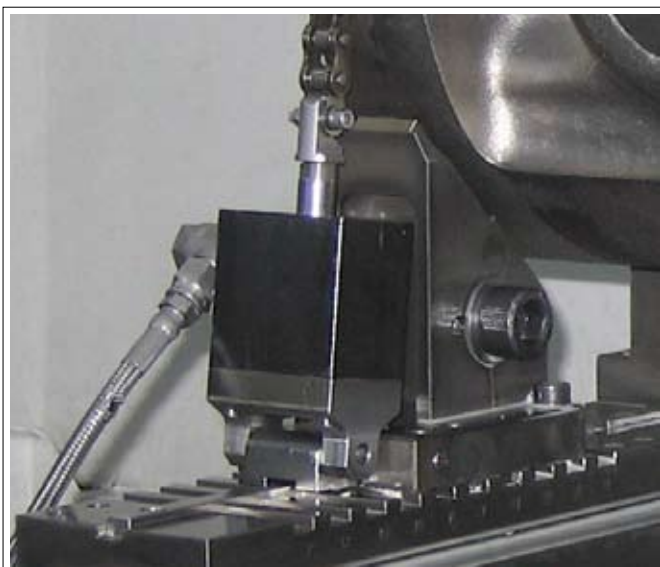

No. 6540GX Counter catch

Order no.	Article no.	Slot	G	S1 Stroke	max. possible clamping force [kN]	Weight [g]
325415	6540GX-12	14, 16, 18	M12	30	15	450
325431	6540GX-16	18, 20, 22, 24	M16	45	40	1240

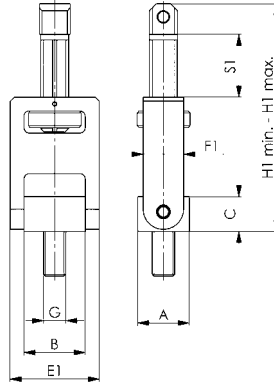

Dimensions

Order no.	Article no.	A	B	C	E1	F1	H1 min.	H1 max.
325415	6540GX-12	36	36	18	49	21	95	125
325431	6540GX-16	37	44	25	64	29	117	162

No. 6540KX Roller chain

Single roller chain DIN 8187. ISO R 606 B, ST 37-2.
Surface: plain.



Order no.	Article no.	Slot	L	M	N	Weight [g]
325456	6540KX-12-125	15	125	20	15	114
325472	6540KX-12-250	15	250	20	15	228
325498	6540KX-12-500	15	500	20	15	455
325514	6540KX-12-1000	15	1000	20	15	910
325530	6540KX-16-125	40	125	33	21	335
325555	6540KX-16-250	40	250	33	21	670
325571	6540KX-16-500	40	500	33	21	1340
325597	6540KX-16-1000	40	1000	33	21	2680

Application:

The individual chain lengths can be joined as required using the connecting links (No. 69540VX). The chain can be shortened to any length as required.

Advantage:

- Chain can be extended or shortened to the required length with ease
- Both sides usable with counter catches or hook ends
- Resistant to temperature influences and soiling
- Chains are tensioned to minimise elongation

On request:

Customised lengths available!

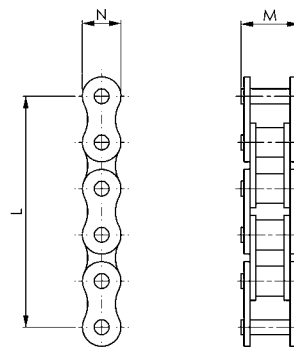

No. 6540VX

Connecting links with spring cotter pin

Order no.	Article no.	L	M	N	max. possible clamping force [kN]	Weight [g]
325605	6540VX-12	15,9	20	15	15	15
325613	6540VX-16	25,4	33	21	40	64

Application:

The connecting links are used for joining two chains together.

Advantage:

Chains simple and quick to combine and replace.

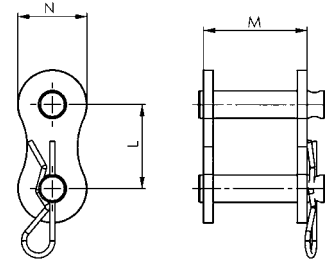

No. 6540FX

Spring cotter pin

Packaging unit: 10 pcs.

Order no.	Article no.	Weight [g]
325621	6540FX-12	0,5
325639	6540FX-16	1,0



No. 6540SX

Protective elements

for workpiece protection.
Packaging unit: 6 pcs.

Order no.	Article no.	Weight [g]
325647	6540SX-12	3
325654	6540SX-16	5

Application:

The protective elements are pushed into the gaps between the chain links.

Advantage:

The workpiece surface is protected.





PUSH-PULL CYLINDERS FOR INDIVIDUAL CLAMPING APPLICATIONS

- > pull force 2.2 to 40 kN
- > operating pressure 350 bar
- > guided or unguided piston rod
- > hardened and chrome-plated piston rod
- > nitrided and burnished body
- > oil supply via threaded port and/or O-ring-sealed ports

PRODUCT OVERVIEW:

Type	Clamping stroke [mm]	Pull force [kN]	No. of models	Operating mode
6927B	25,5 - 51,0	5,9 - 17,5	4	single-acting
6951KZ/KZN	14,5 - 30,0	2,2 - 40,0	8	single / double-acting
6951FZ/FZN	14,5 - 30,0	2,2 - 40,0	8	single / double-acting
6951GZ/GZN	14,5 - 51,0	2,2 - 40,0	10	single / double-acting

PRODUCT EXAMPLES:

NO. 6927B



- > Pull force: 5,9 - 17,5 kN
- > connection type: threaded port

NO. 6951KZ



- > Pull force: 2,2 - 40 kN
- > connection type: O-ring or threaded port

NO. 6951FZ



- > Pull force: 2,2 - 40 kN
- > connection type: O-ring or threaded port

No. 6927B

Pull Cylinder, block type

single acting,
max. operating pressure 350 bar.

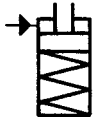

Order no.	Article no.	Pull force at 350 bar [kN]	Stroke B [mm]	Vol. pull [cm ³]	Piston area pull [cm ²]	Weight [g]
68064	6927B-06-1	5,9	25,5	4,4	1,7	1075
68080	6927B-06-2	5,9	51,0	8,8	1,7	1433
68106	6927B-18-1	17,5	25,5	12,7	5,0	1483
68122	6927B-18-2	17,5	51,0	25,4	5,0	1905

Design:

Cylinder housing made of steel, hardened and blued. Piston rod with internal thread, case-hardened and chrome plated. Wiper at piston rod prevents from contamination.

Application:

Universal pull cylinder for various applications.

Features:

Piston rod not guided. Tapped piston rod ends allow the use of custom end attachments. Clamping bars can be attached like the swivel clamps. Cylinder body with longitudinal and crosswise mounting holes.

Note:

For single acting cylinders there is risk of sucking in coolant through the breather port. In such cases the breather port has to be piped to a clean protected area. The system has to be completely vented during installation.

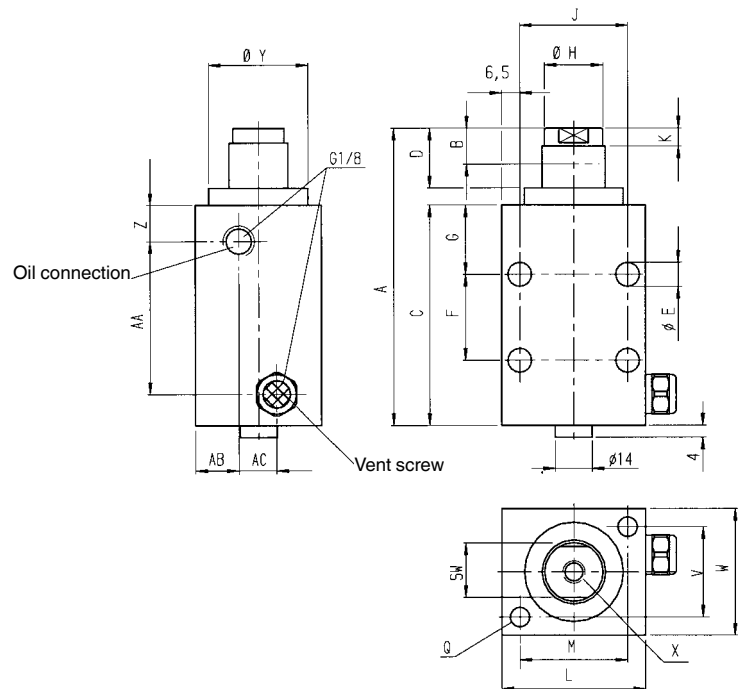

Dimensions

Order no.	Article no.	A	C	D	E	F	G	H	J	K	L	M	Q	SW	V	W	X	Y	Z	AA	AB	AC
68064	6927B-06-1	109,0	69,5	33,5	9	-	26,5	20,1	38	6,5	51,0	38	7	17	31,5	44,5	M8x11	35,0	12,5	41	8	14,5
68080	6927B-06-2	163,5	98,5	59,0	9	41	26,5	20,1	38	6,5	51,0	38	7	17	31,5	44,5	M8x11	35,0	12,5	70	8	14,5
68106	6927B-18-1	111,0	69,5	35,5	9	-	26,5	28,2	51	9,0	63,5	48	9	25	35,5	51,0	M12x13	44,5	12,5	41	8	17,5
68122	6927B-18-2	165,0	98,5	61,0	9	41	26,5	28,2	51	9,0	63,5	48	9	25	35,5	51,0	M12x13	44,5	12,5	70	8	17,5

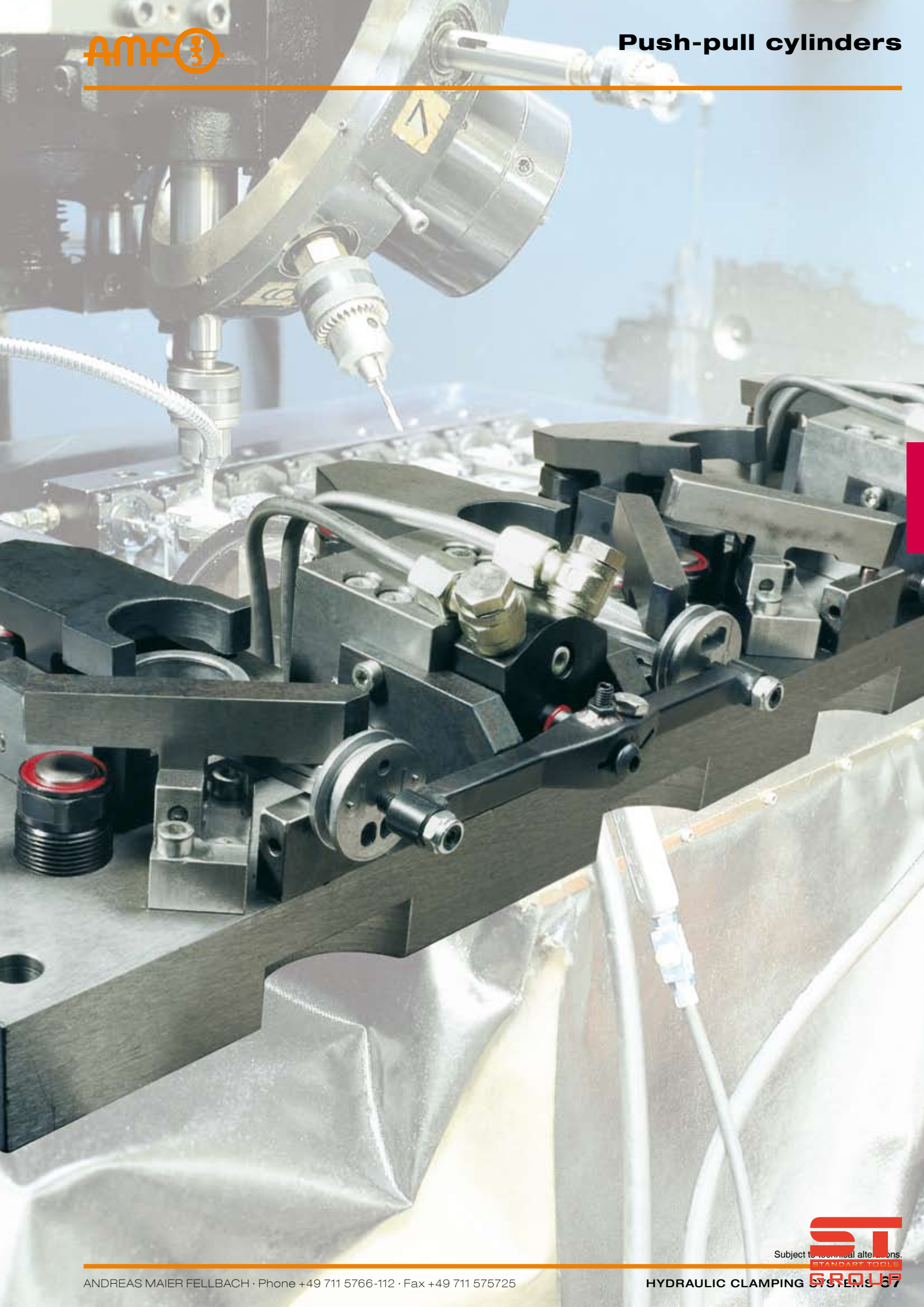

No. 6951KZ

Push-Pull Cylinder, top-flange-mounting, with guided piston rod

single and double acting,
max. operating pressure 350 bar,
min. operating pressure 40 bar.

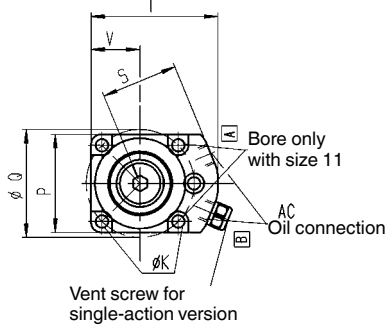
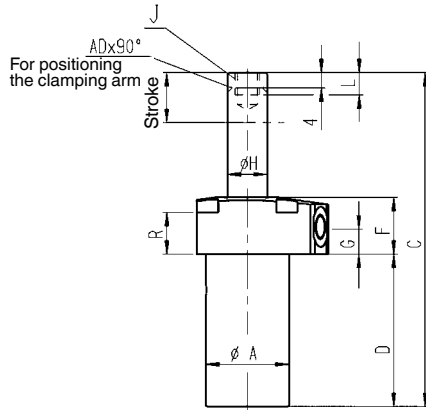
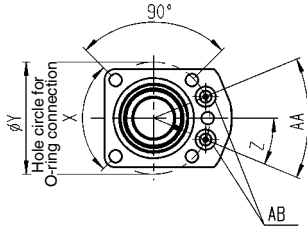
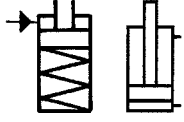

[A] = Pull
[B] = Push

Order no.	Article no.	Push force at 350 bar [kN]	Pull force at 350 bar [kN]	Stroke [mm]	Vol. push [cm³]	Vol. pull [cm³]	Q max. [l/min]	Weight [g]
66498	6951KZ-02-10	-	2,2	14,5	-	0,92	0,165	372
66530	6951KZ-05-10	-	6,6	20,0	-	3,82	0,40	903
66571	6951KZ-11-10	-	13,9	29,5	-	11,90	1,64	1520
66514	6951KZ-02-20	5,6	2,2	14,5	2,3	0,92	0,165	372
66555	6951KZ-05-20	13,5	6,6	20,0	7,8	3,82	0,40	903
66597	6951KZ-11-20	27,7	13,9	29,5	23,0	11,90	1,64	1520

Design:

Cylinder housing made of steel, hardened and blued. Piston rod with internal thread, case-hardened and chrome plated, and clamp arm positioning. O-ring for flange seal. Wiper at piston rod prevents from contamination. Single acting version with return spring out of stainless steel.

Application:

Universal Push-Pull Cylinder for various applications.

Features:

Each model is available for single or double acting operation. The internal thread at piston rod allows mounting of attachments like clamping arms and set screws. Oil supply by means of threaded port or manifold.

Note:

The piston is guided, therefore, the max. permissible oil flow rate Q max. must be observed in order to protect the mechanism. No force must be introduced at the piston when mounting accessory. For single acting cylinders there is risk of sucking in coolant through the breather port. In such cases the breather port has to be piped to a clean protected area. The system has to be completely vented during installation. Replacement O-ring for flange connection is available on request under Order No. 183608.



Dimensions

Order no.	Article no.	dia. A	C	D	F	G	dia. H	J	dia. K	L	P	dia. Q	R	S	T	V	X	dia. Y	Z	AA	AB	AC	AD
66498	6951KZ-02-10	25,2	101,5	45,0	25	12,0	11,13	M6	3x6	7	45	40,0	18,0	31,0	47	15,5	120	42	30°	60°	O-Ring 7,65x1,78	G1/8	3,2
66530	6951KZ-05-10	36,3	134,0	66,5	25	11,0	15,88	M10	3x7	12	57	50,0	17,8	33,5	54	19,0	120	50	55°	110°	O-Ring 7,65x1,78	G1/8	4,8
66571	6951KZ-11-10	44,2	172,0	81,0	30	14,5	22,23	M12	5x9	13	55	59,5	22,1	42,0	71	27,5	90	62	22,5°	45°	O-Ring 7,65x1,78	G1/4	4,8
66514	6951KZ-02-20	25,2	101,5	45,0	25	12,0	11,13	M6	3x6	7	45	40,0	18,0	31,0	47	15,5	120	42	30°	60°	O-Ring 7,65x1,78	G1/8	3,2
66555	6951KZ-05-20	36,3	134,0	66,5	25	11,0	15,88	M10	3x7	12	57	50,0	17,8	33,5	54	19,0	120	50	55°	110°	O-Ring 7,65x1,78	G1/8	4,8
66597	6951KZ-11-20	44,2	172,0	81,0	30	14,5	22,23	M12	5x9	13	55	59,5	22,1	42,0	71	27,5	90	62	22,5°	45°	O-Ring 7,65x1,78	G1/4	4,8

No. 6951KZN

Push-Pull Cylinder, top-flange-mounting, with guided piston rod

double acting,
max. operating pressure 350 bar,
min. operating pressure 40 bar.

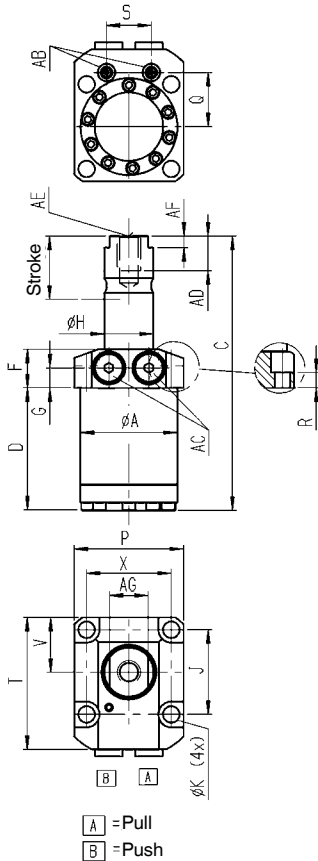
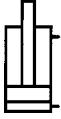

Order no.	Article no.	Push force at 350 bar [kN]	Pull force at 350 bar [kN]	Stroke [mm]	Vol. push [cm ³]	Vol. pull [cm ³]	Q max. [l/min]	Weight [g]
69336	6951KZN-22-20	54	26	28	43,0	21,0	2,5	2590
65995	6951KZN-33-20	80	40	30	68,6	34,3	2,5	4355

Design:

Cylinder housing made of steel, hardened and blued. Piston rod with internal thread, case-hardened and chrome plated. O-Ring für Flanschabdichtung. Wiper at piston rod prevents from contamination.

Application:

Universal Push-Pull Cylinder for various applications.

Features:

The internal thread at piston rod allows mounting of attachments like clamping arms and set screws. Oil supply by means of threaded port or manifold.

Note:

The piston is guided, therefore, the max. permissible oil flow rate Q max must be observed in order to protect the mechanism. No force must be introduced at the piston when mounting accessory. The system has to be completely vented during installation. Replacement O-ring for flange connection is available on request under Order No. 183608.



Dimensions

Order no.	Article no.	dia. A	C	D	F	G	dia. H	J	dia. K	P	Q	R	S	T	V	X	AB	AC	AD	AE	AF	AG
69336	6951KZN-22-20	62,8	186	79,5	25	13	31,75	55	10,7	70	35,0	12,8	29,1	85	35,0	55	O-Ring 7,65x1,78	G 1/4	19	M16	12,7	27
65995	6951KZN-33-20	77,0	197	89,0	25	13	38,10	70	13,5	89	40,6	12,3	35,6	100	44,5	70	O-Ring 7,65x1,78	G 1/4	19	M16	12,7	33

No. 6951FZ

Push-Pull Cylinder, base-flange-mounting, with guided piston rod

single and double acting,
max. operating pressure 350 bar,
min. operating pressure 40 bar.

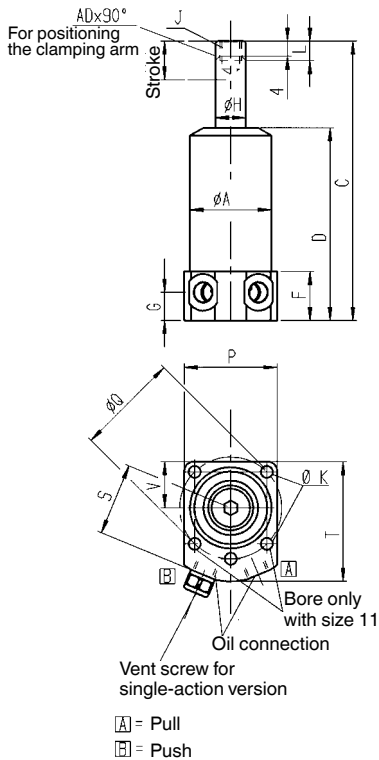
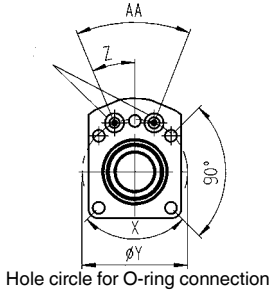
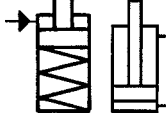

Order no.	Article no.	Push force at 350 bar [kN]	Pull force at 350 bar [kN]	Stroke [mm]	Vol. push [cm ³]	Vol. pull [cm ³]	Q max. [l/min]	Weight [g]
66480	6951FZ-02-10	-	2,2	14,5	-	0,92	0,165	463
66522	6951FZ-05-10	-	6,6	20,0	-	3,82	0,400	1150
66563	6951FZ-11-10	-	13,9	29,5	-	11,90	1,640	2050
66506	6951FZ-02-20	5,6	2,2	14,5	2,3	0,92	0,165	463
66548	6951FZ-05-20	13,5	6,6	20,0	7,8	3,82	0,400	1150
66589	6951FZ-11-20	27,7	13,9	29,5	23,0	11,90	1,640	2050

Design:

Cylinder housing made of steel, hardened and blued. Piston rod with internal thread, case-hardened and chrome plated, and clamp arm positioning. O-ring for flange seal. Wiper at piston rod prevents from contamination. Single acting version with return spring out of stainless steel.

Application:

Universal Push-Pull Cylinder for various applications.

Features:

Each model is available for single or double acting operation. The internal thread at piston rod allows mounting of attachments like clamping arms and set screws. Oil supply by means of threaded port or manifold.

Note:

The piston is guided, therefore, the max. permissible oil flow rate Q max. must be observed in order to protect the mechanism. No force must be introduced at the piston when mounting accessory. For single acting cylinders there is risk of sucking in coolant through the breather port. In such cases the breather port has to be piped to a clean protected area. The system has to be completely vented during installation. Replacement O-ring for flange connection is available on request under Order No. 183608.



Dimensions

Order no.	Article no.	dia. A	C	D	F	G	dia. H	J	dia. K	L	P	dia. Q	S	T	V	X	dia. Y	Z	AA	AB	AC	AD
66480	6951FZ-02-10	26,8	103	71,0	26,5	13,5	11,13	M6	3x6	10	45	40,0	31,0	47	15,5	120	42	30,0	60°	O-Ring 7,65x1,78	G1/8	3,2
66522	6951FZ-05-10	38,0	135	92,5	25,0	15,0	15,88	M10	3x7	16	57	50,0	33,5	54	19,0	120	50	55,0	110°	O-Ring 7,65x1,78	G1/8	4,8
66563	6951FZ-11-10	45,4	173	112,5	28,5	16,5	22,23	M12	5x9	19	55	59,5	42,0	71	27,5	90	62	22,5	45°	O-Ring 7,65x1,78	G1/4	4,8
66506	6951FZ-02-20	26,8	103	71,0	26,5	13,5	11,13	M6	3x6	10	45	40,0	31,0	47	15,5	120	42	30,0	60°	O-Ring 7,65x1,78	G1/8	3,2
66548	6951FZ-05-20	38,0	135	92,5	25,0	15,0	15,88	M10	3x7	16	57	50,0	33,5	54	19,0	120	50	55,0	110°	O-Ring 7,65x1,78	G1/8	4,8
66589	6951FZ-11-20	45,4	173	112,5	28,5	16,5	22,23	M12	5x9	19	55	59,5	42,0	71	27,5	90	62	22,5	45°	O-Ring 7,65x1,78	G1/4	4,8

No. 6951FZN

Push-Pull Cylinder, base-flange-mounting, with guided piston rod

double acting,
max. operating pressure 350 bar,
min. operating pressure 40 bar.

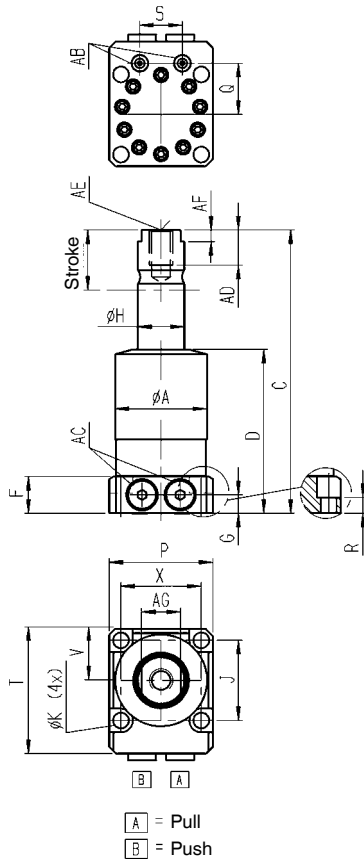

Order no.	Article no.	Push force at 350 bar [kN]	Pull force at 350 bar [kN]	Stroke [mm]	Vol. push [cm ³]	Vol. pull [cm ³]	Q max. [l/min]	Weight [g]
69351	6951FZN-22-20	54	26	28	43,0	21,0	2,5	3070
66944	6951FZN-33-20	80	40	30	68,6	34,3	2,5	4854

Design:

Cylinder housing made of steel, hardened and blued. Piston rod with internal thread, case-hardened and chrome plated. O-Ring für Flanschabdichtung. Wiper at piston rod prevents from contamination.

Application:

Universal Push-Pull Cylinder for various applications.

Features:

The internal thread at piston rod allows mounting of attachments like clamping arms and set screws. Oil supply by means of threaded port or manifold.

Note:

The piston is guided, therefore, the max. permissible oil flow rate Q max must be observed in order to protect the mechanism. No force must be introduced at the piston when mounting accessory. The system has to be completely vented during installation. Replacement O-ring for flange connection is available on request under Order No. 183608.



Dimensions

Order no.	Article no.	dia. A	C	D	F	G	dia. H	J	dia. K	P	Q	R	S	T	V	X	AB	AC	AD	AE	AF	AG
69351	6951FZN-22-20	62,8	194	112,0	25	13	31,75	55	10,7	70	35,0	13,2	29,1	85	35,0	55	O-Ring 7,65x1,78	G1/4	19	M16	12,7	27
66944	6951FZN-33-20	79,1	205	121,4	25	13	38,10	70	13,5	89	41,7	12,3	34,5	100	44,4	70	O-Ring 7,65x1,78	G1/4	19	M16	12,7	33

No. 6951GZ

Push-Pull Cylinder, thread-flange-mounting, with guided piston rod

single and double acting,
max. operating pressure 350 bar,
min. operating pressure 40 bar.

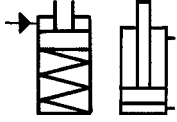

Order no.	Article no.	Push force at 350 bar [kN]	Pull force at 350 bar [kN]	Stroke [mm]	Vol. push [cm³]	Vol. pull [cm³]	Q max. [l/min]	Weight [g]
66605	6951GZ-02-10	-	2,2	14,5	-	0,92	0,165	308
66670	6951GZ-05-10	-	6,6	20,0	-	3,82	0,400	771
66712	6951GZ-11-10	-	13,9	29,5	-	11,90	1,640	1424
66613	6951GZ-02-20	5,6	2,2	14,5	2,3	0,92	0,165	300
66696	6951GZ-05-20	13,5	6,6	20,0	7,8	3,82	0,400	744
66795	6951GZ-05-200	13,5	6,6	31,0	11,9	5,90	0,400	850
66738	6951GZ-11-20	27,7	13,9	29,5	23,0	11,90	1,640	1379
66928	6951GZ-11-200	27,7	13,9	51,0	40,0	20,50	1,640	1941

Design:

Cylinder housing made of steel, hardened and blued. Piston rod with internal thread, case-hardened and chrome plated, and clamp arm positioning. Wiper at piston rod prevents from contamination. Single acting version with return spring out of stainless steel.

Application:

Universal Push-Pull Cylinder for various applications.

Features:

Each model is available for single or double acting operation. The internal thread at piston rod allows mounting of attachments like clamping arms and set screws.

Note:

The piston is guided, therefore, the max. permissible oil flow rate Q max. must be observed in order to protect the mechanism. No force must be introduced at the piston when mounting accessory. For single acting cylinders there is risk of sucking in coolant through the breather port. In such cases the breather port has to be piped to a clean protected area. The system has to be completely vented during installation. Suitable flange nuts DIN 70852.

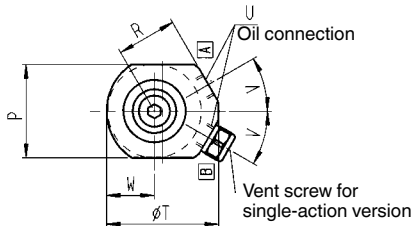
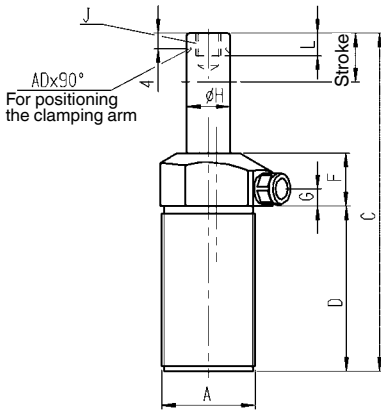

[A] = Pull
[B] = Push



Dimensions

Order no.	Article no.	A	C	D	F	G	dia. H	J	L	P	R	dia. T	U	V	W	AD
66605	6951GZ-02-10	M28x1,5	102,0	51,0	19,0	6,5	11,13	M6	10	32,0	20,5	38,0	G1/8	25°	14,0	3,2
66670	6951GZ-05-10	M38x1,5	134,0	63,5	28,0	9,5	15,88	M10	16	38,0	26,0	47,5	G1/8	35°	19,5	4,8
66712	6951GZ-11-10	M48x1,5	172,0	83,0	28,0	9,0	22,23	M12	19	47,5	31,5	60,0	G1/4	30°	25,5	4,8
66613	6951GZ-02-20	M28x1,5	102,0	51,0	19,0	6,5	11,13	M6	10	32,0	20,5	38,0	G1/8	25°	14,0	3,2
66696	6951GZ-05-20	M38x1,5	134,0	63,5	28,0	9,5	15,88	M10	16	38,0	26,0	47,5	G1/8	35°	19,5	4,8
66795	6951GZ-05-200	M38x1,5	167,0	86,0	27,5	9,5	15,88	M10	16	38,0	26,0	47,5	G1/8	35°	19,5	4,8
66738	6951GZ-11-20	M48x1,5	172,0	83,0	28,0	9,0	22,23	M12	19	47,5	31,5	60,0	G1/4	30°	25,5	4,8
66928	6951GZ-11-200	M48x1,5	235,5	124,0	29,5	10,5	22,23	M12	19	47,5	31,5	60,0	G1/4	30°	25,5	4,8

No. 6951GZN

Push-Pull Cylinder, thread-flange-mounting, with guided piston rod

double acting,
max. operating pressure 350 bar,
min. operating pressure 40 bar.

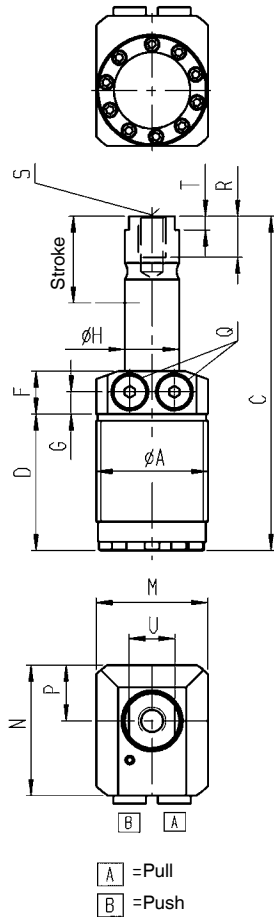
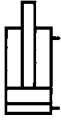

Order no.	Article no.	Push force at 350 bar [kN]	Pull force at 350 bar [kN]	Stroke [mm]	Vol. push [cm ³]	Vol. pull [cm ³]	Q max. [l/min]	Weight [g]
69377	6951GZN-22-20	54	26	28	43,0	21,0	2,5	2590
65870	6951GZN-33-20	80	40	30	68,6	34,3	2,5	4174

Design:

Cylinder housing made of steel, hardened and blued. Piston rod with internal thread, case-hardened and chrome plated. Wiper at piston rod prevents from contamination.

Application:

Universal Push-Pull Cylinder for various applications.

Features:

The internal thread at piston rod allows mounting of attachments like clamping arms and set screws.

Note:

The piston is guided, therefore, the max. permissible oil flow rate Q max must be observed in order to protect the mechanism. No force must be introduced at the piston when mounting accessory. The system has to be completely vented during installation. Suitable flange nuts DIN 70852.



Dimensions

Order no.	Article no.	dia. A	C	D	F	G	dia. H	M	N	P	Q	R	S	T	U
69377	6951GZN-22-20	M65x1,5	186	79,5	25	13	31,75	65	76,0	32,5	G1/4	19	M16	12,7	27
65870	6951GZN-33-20	M80x2,2	197	88,9	25	13	38,10	80	88,4	40,0	G1/4	19	M16	12,7	33

SWING CLAMPS - THE SOLUTION FOR COST-EFFECTIVE HYDRAULIC CLAMPING OF WORKPIECES!

DESIGN:

Burnished body, hardened and ground piston rod. Swing clamps are delivered without clamping arm.

APPLICATION:

Swing clamps are used in fixtures of all kinds, especially in applications where workpieces must be freely accessible and loaded from above. Workpieces with complex geometries can be clamped using special clamping arms (available upon request).

FEATURES:

Design variants: > **cartridge flange** > **top flange** > **base flange** > **thread flange**

Top and base-flange models accommodate O-ring as well as threaded hydraulic connections.

The swing motion is realized by a patented ball-guide mechanism.

Standard swivel angle is 90°. Other swivel angles are available on request.

Swing-angle tolerance = $\pm 3^\circ$, repeat accuracy of clamping position = $\pm 1^\circ$

The newly designed clamping-arm mount prevents the induction of forces into the swing mechanism during assembly.

IMPORTANT NOTE:

Clamping arm length, max. permissible flow rate Q max. (see diagram) and clamping arm weight must be observed! In case of a larger flow rates, a throttle/check valve must be connected upstream.

The motion of the swing clamp must not be obstructed. Clamping must only be done in the vertical stroke area.

Code of types:

- Type 11** = single-acting, right swinging
- Type 12** = single-acting, left swinging
- Type 21** = double-acting, right swinging
- Type 22** = double-acting, left swinging
- Type 210** = double-acting, right swinging, extended stroke
- Type 220** = double-acting, left swinging, extended stroke

POSITIONING:

Positioning bore for clamping arm:

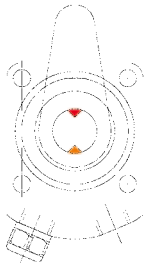

Push-pull cylinder

SWING DIRECTIONS:

Positioning bore for clamping arm:

Swing clamp - right swinging

left swinging

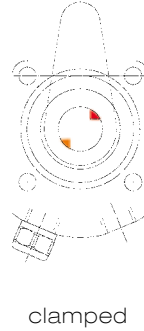
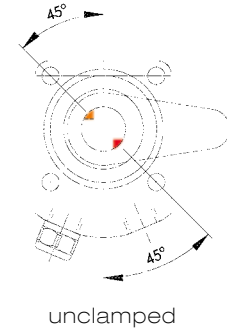
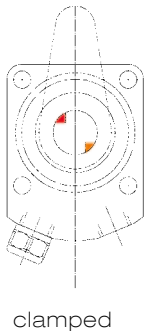
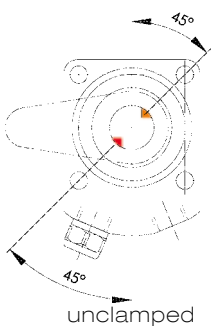

SWING CLAMPS FOR DEMANDING CLAMPING APPLICATIONS

- > clamping force 2.2 - 40 kN
- > operating pressure 350 bar
- > easy change of swing direction (version 2 - 11 kN)
- > hardened and chrome-plated piston rod
- > nitrided body
- > oil supply via threaded port and/or O-ring-sealed ports
- > optimal size-to-clamping-force ratio

PRODUCT OVERVIEW:

Clamping force [kN]	Clamping stroke [mm]	Total stroke [mm]	Threaded design	Top flange	Base flange	Threaded flange	Operating mode
2	6,0	14,5	√	-	-	-	double-acting
2	6,0	14,5	-	√	√	√	single / double-acting
5	8,0 19,0	20,0 31,0	-	√	√	√	single / double-acting
11	13,0 34,0	29,5 51,0	-	√	√	√	single / double-acting
22	15,0	28,0	-	√	√	√	single / double-acting
33	15,7 31,7	30,0 45,5	-	√	√	√	single / double-acting

PRODUCT EXAMPLES:

NO. 6951K



- > Clamping force: 2,2 - 40 kN
- > Connection type: O-ring or threaded port

NO. 6951F



- > Clamping force: 2,2 - 40 kN
- > Connection type: O-ring or threaded port

NO. 6951G



- > Clamping force: 2,2 - 40 kN
- > Connection type: threaded port

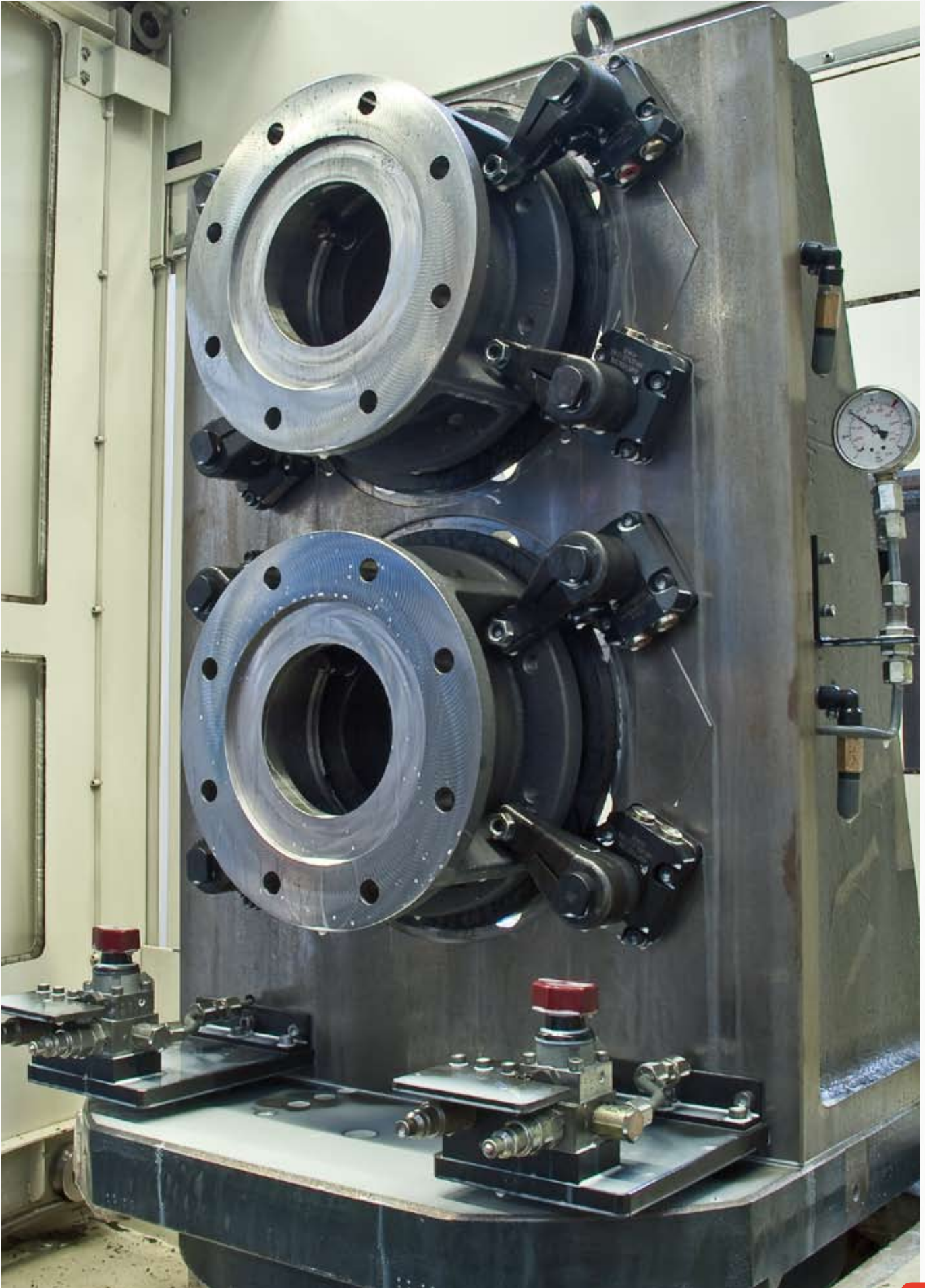

Subject to technical alterations.

No. 6952E

Swing clamp, cartridge flange

double acting,
max. operating pressure 350 bar,
min. operating pressure 40 bar.

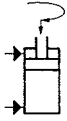

Order no.	Article no.	Clamping force at 350 bar clamp* [kN]	Clamping stroke M [mm]	Total stroke N [mm]	Oil capacity clamp [cm ³]	Oil capacity unclamp [cm ³]	effective piston area clamp [cm ²]	effective piston area unclamp [cm ²]	Max. oil flow rate Q max. [l/min]	Weight [g]
325886	6952E-02-21	2	6	14,5	0,92	2,46	0,63	1,7	0,165	355
325894	6952E-02-22	2	6	14,5	0,92	2,46	0,63	1,7	0,165	355

* Clamping forces with short clamping arm.

Design:

Cylinder housing made of steel, hardened and blued. Piston rod with internal thread, case-hardened and chrome plated. Wiper at piston rod. Clamp arm not included.

Application:

The swing clamp is used particularly in fixtures in which the workpieces must be freely accessible and placed from above. Workpieces with dedicated shapes can also be clamped using special clamp arms (available on request).

Note:

The clamping arm can only be fastened when screwed in, since the exact position cannot be defined in advance.

Dimensions

Order no.	Article no.	A	ØA1 ()	ØA2 ()	B	C	D	E	F	dia. H	ØH1 ()	J	P	dia. T	max. torque
325886	6952E-02-21	M28x1,5	25 f7	24	108,5	101,5	58	17	15,5	12	11,13	M6	SW32	36	100
325894	6952E-02-22	M28x1,5	25 f7	24	108,5	101,5	58	17	15,5	12	11,13	M6	SW32	36	100

Installation dimensions

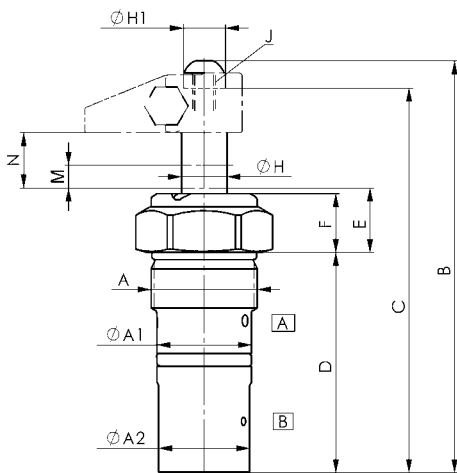

[A] = clamp
[B] = unclamp

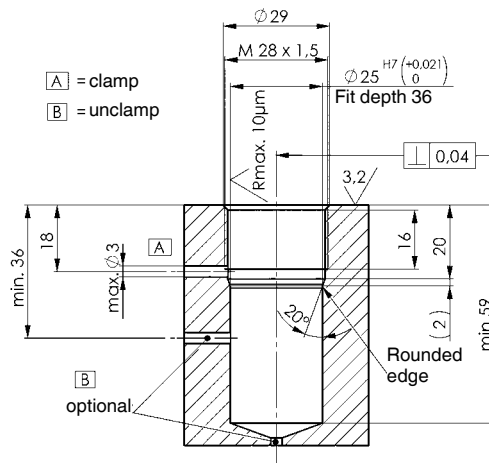
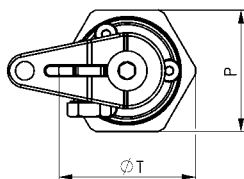

No. 6951K

Swing Clamp, top-flange-mounting

single and double acting,
max. operating pressure 350 bar,
min. operating pressure 40 bar.

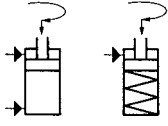

Order no.	Article no.	Clamp. force at 350 bar clamp* [kN]	Clamp. force at 350 bar unclamp* [kN]	Clamping stroke M [mm]	Total stroke N [mm]	Oil capacity clamp [cm ³]	Oil capacity unclamp [cm ³]	effective piston area clamp [cm ²]	effective piston area unclamp [cm ²]	Max. oil flow rate Q max. [l/min]	Weight [g]
68726	6951K-02-11	2	-	6	14,5	0,92	-	0,63	-	0,165	372
68742	6951K-02-12	2	-	6	14,5	0,92	-	0,63	-	0,165	372
68791	6951K-05-11	5	-	8	20,0	3,82	-	1,90	-	0,400	903
68833	6951K-05-12	5	-	8	20,0	3,82	-	1,90	-	0,400	903
68890	6951K-11-11	11	-	13	29,5	11,90	-	4,04	-	1,640	1520
68916	6951K-11-12	11	-	13	29,5	11,90	-	4,04	-	1,640	1520
68767	6951K-02-21	2	5,6	6	14,5	0,92	2,3	0,63	1,60	0,165	358
68775	6951K-02-22	2	5,6	6	14,5	0,92	2,3	0,63	1,60	0,165	358
68858	6951K-05-21	5	13,5	8	20,0	3,82	7,8	1,90	3,88	0,400	871
68874	6951K-05-22	5	13,5	8	20,0	3,82	7,8	1,90	3,88	0,400	871
68932	6951K-11-21	11	27,7	13	29,5	11,90	23,0	4,04	7,92	1,640	1465
68957	6951K-11-22	11	27,7	13	29,5	11,90	23,0	4,04	7,92	1,640	1465

* Clamping forces with short clamping arm.

Design:

Cylinder housing made of steel, hardened and blued. Piston rod case-hardened and chrome plated. Piston rod with internal thread. O-ring for flange seal. Wiper at piston rod. For single-acting models, return spring made of stainless steel. Clamp arm not included.

Application:

The swing clamp is used particularly in fixtures in which the workpieces must be freely accessible and placed from above. Workpieces with difficult shapes can also be clamped using special clamp arms (available on request).

Features:

Each cylinder size is available for single- or double-acting operation. Oil supply via threaded connection or oil channel in the fixture body. The swing motion employs a patented ball guide mechanism.

Note:

The piston is guided, and so the max. permissible oil flow rate Q max. as well as the clamping arm length and weight must be observed. When mounting accessories at the piston, no force may be applied to the piston. For single-acting cylinders, there is risk of sucking in coolant through the breather port. In such cases, the breather port has to be moved via a connection line to a clean protected area. When installing, ensure that all air is bled from the system. Replacement O-ring for flange connection is available under Order No. 183608. Other swivel angles are available on request.

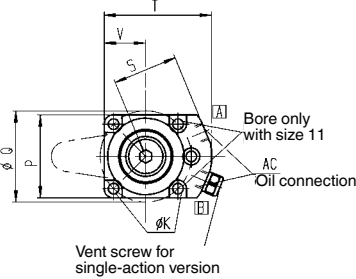
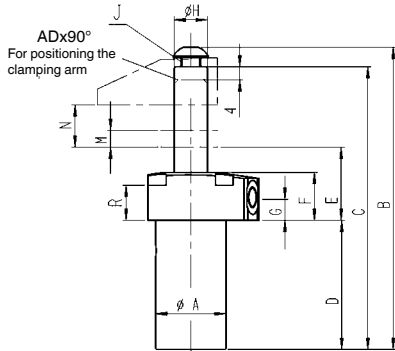
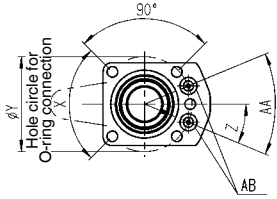

[A] = clamp
[K] = unclamp



Dimensions

Order no.	Article no.	dia. A	B	C	D	E	F	G	dia. H	J	dia. K	P	dia. Q	R	S	T	V	X	dia. Y	Z	AA	AB	AC	AD
68726	6951K-02-11	25,2	108	101,5	44,0	31,0	26	13,0	11,13	M6	3x6	45	40,0	18,0	31,0	47	15,5	120°	42	30°	60°	O-ring 7,65x1,78	G1/8	3,2
68742	6951K-02-12	25,2	108	101,5	44,0	31,0	26	13,0	11,13	M6	3x6	45	40,0	18,0	31,0	47	15,5	120°	42	30°	60°	O-ring 7,65x1,78	G1/8	3,2
68791	6951K-05-11	36,3	143	134,0	64,5	31,5	27	13,0	15,88	M10	3x7	57	50,0	17,8	33,5	54	19,0	120°	50	55°	110°	O-ring 7,65x1,78	G1/8	4,8
68833	6951K-05-12	36,3	143	134,0	64,5	31,5	27	13,0	15,88	M10	3x7	57	50,0	17,8	33,5	54	19,0	120°	50	55°	110°	O-ring 7,65x1,78	G1/8	4,8
68890	6951K-11-11	44,2	185	172,0	81,0	36,0	30	14,5	22,23	M12	5x9	55	59,5	22,1	42,0	71	27,5	90°	62	22,5°	45°	O-ring 7,65x1,78	G1/4	4,8
68916	6951K-11-12	44,2	185	172,0	81,0	36,0	30	14,5	22,23	M12	5x9	55	59,5	22,1	42,0	71	27,5	90°	62	22,5°	45°	O-ring 7,65x1,78	G1/4	4,8
68767	6951K-02-21	25,2	108	101,5	44,0	31,0	26	13,0	11,13	M6	3x6	45	40,0	18,0	31,0	47	15,5	120°	42	30°	60°	O-ring 7,65x1,78	G1/8	3,2
68775	6951K-02-22	25,2	108	101,5	44,0	31,0	26	13,0	11,13	M6	3x6	45	40,0	18,0	31,0	47	15,5	120°	42	30°	60°	O-ring 7,65x1,78	G1/8	3,2
68858	6951K-05-21	36,3	143	134,0	64,5	31,5	27	13,0	15,88	M10	3x7	57	50,0	17,8	33,5	54	19,0	120°	50	55°	110°	O-ring 7,65x1,78	G1/8	4,8
68874	6951K-05-22	36,3	143	134,0	64,5	31,5	27	13,0	15,88	M10	3x7	57	50,0	17,8	33,5	54	19,0	120°	50	55°	110°	O-ring 7,65x1,78	G1/8	4,8
68932	6951K-11-21	44,2	185	172,0	81,0	36,0	30	14,5	22,23	M12	5x9	55	59,5	22,1	42,0	71	27,5	90°	62	22,5°	45°	O-ring 7,65x1,78	G1/4	4,8
68957	6951K-11-22	44,2	185	172,0	81,0	36,0	30	14,5	22,23	M12	5x9	55	59,5	22,1	42,0	71	27,5	90°	62	22,5°	45°	O-ring 7,65x1,78	G1/4	4,8

Subject to technical alterations.

No. 6951F

Swing Clamp, base-flange-mounting

single and double acting,
max. operating pressure 350 bar,
min. operating pressure 40 bar.

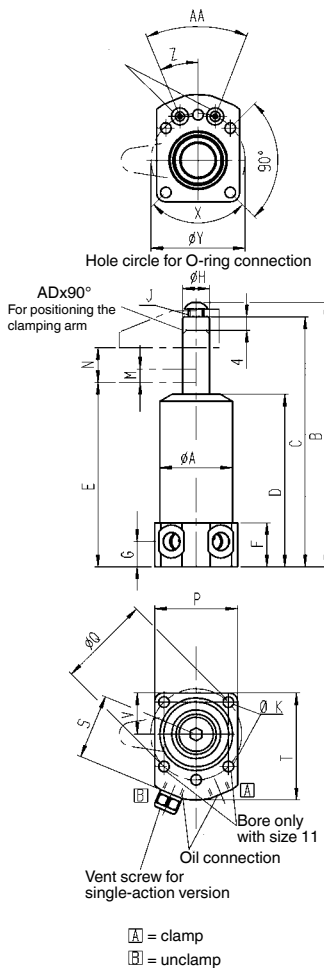
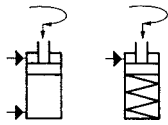

Order no.	Article no.	Clamp. force at 350 bar clamp* [kN]	Clamp. force at 350 bar unclamp* [kN]	Clamping stroke M [mm]	Total stroke N [mm]	Oil capacity clamp [cm ³]	Oil capacity unclamp [cm ³]	effective piston area clamp [cm ²]	effective piston area unclamp [cm ²]	Max. oil flow rate Q max. [l/min]	Weight [g]
68221	6951F-02-11	2	-	6	14,5	0,92	-	0,63	-	0,165	630
68247	6951F-02-12	2	-	6	14,5	0,92	-	0,63	-	0,165	463
68304	6951F-05-11	5	-	8	20,0	3,82	-	1,90	-	0,400	1152
68320	6951F-05-12	5	-	8	20,0	3,82	-	1,90	-	0,400	1152
68387	6951F-11-11	11	-	13	29,5	11,90	-	4,04	-	1,640	1800
68403	6951F-11-12	11	-	13	29,5	11,90	-	4,04	-	1,640	1800
68262	6951F-02-21	2	5,6	6	14,5	0,92	2,3	0,63	1,60	0,165	463
68288	6951F-02-22	2	5,6	6	14,5	0,92	2,3	0,63	1,60	0,165	463
68346	6951F-05-21	5	13,5	8	20,0	3,82	7,8	1,90	3,88	0,400	1139
68361	6951F-05-22	5	13,5	8	20,0	3,82	7,8	1,90	3,88	0,400	1139
68411	6951F-11-21	11	27,7	13	29,5	11,90	23,0	4,04	7,92	1,640	1996
68437	6951F-11-22	11	27,7	13	29,5	11,90	23,0	4,04	7,92	1,640	1996

* Clamping forces with short clamping arm.

Design:

Cylinder housing made of steel, hardened and blued. Piston rod with internal thread, case-hardened and chrome plated. O-ring for flange seal. Wiper at piston rod. For single-acting models, return spring made of stainless steel. Clamp arm not included.

Application:

The swing clamp is used particularly in fixtures in which the workpieces must be freely accessible and placed from above. Workpieces with difficult shapes can also be clamped using special clamp arms (available on request).

Features:

Each cylinder size is available for single- or double-acting operation. Oil supply via threaded connection or oil channel in the fixture body. The swing motion employs a patented ball guide mechanism.

Note:

The piston is guided, and so the max. permissible oil flow rate Q max. as well as the clamping arm length and weight must be observed. When mounting accessories at the piston, no force may be applied to the piston. For single-acting cylinders, there is risk of sucking in coolant through the breather port. In such cases, the breather port has to be moved via a connection line to a clean protected area. When installing, ensure that all air is bled from the system. Replacement O-ring for flange connection is available under Order No. 183608. Other swivel angles are available on request.



Dimensions

Order no.	Article no.	dia. A	B	C	D	E	F	G	dia. H	J	dia. K	P	dia. Q	S	T	V	X	dia. Y	Z	AA	AB	AC	AD
68221	6951F-02-11	26,8	109,5	103	71,0	76,0	26,5	13,5	11,13	M6	3x6	45	40,0	31,0	47	15,5	120°	42	30°	60°	O-ring 7,65x1,78	G1/8	3,2
68247	6951F-02-12	26,8	109,5	103	71,0	76,0	26,5	13,5	11,13	M6	3x6	45	40,0	31,0	47	15,5	120°	42	30°	60°	O-ring 7,65x1,78	G1/8	3,2
68304	6951F-05-11	38,0	145,0	135	92,5	97,0	25,0	15,0	15,88	M10	3x7	57	50,0	33,5	54	19,0	120°	50	55°	110°	O-ring 7,65x1,78	G1/8	4,8
68320	6951F-05-12	38,0	145,0	135	92,5	97,0	25,0	15,0	15,88	M10	3x7	57	50,0	33,5	54	19,0	120°	50	55°	110°	O-ring 7,65x1,78	G1/8	4,8
68387	6951F-11-11	45,4	186,0	173	112,5	118,5	28,5	16,5	22,23	M12	5x9	55	59,5	42,0	71	27,5	90°	62	22,5°	45°	O-ring 7,65x1,78	G1/4	4,8
68403	6951F-11-12	45,4	186,0	173	112,5	118,5	28,5	16,5	22,23	M12	5x9	55	59,5	42,0	71	27,5	90°	62	22,5°	45°	O-ring 7,65x1,78	G1/4	4,8
68262	6951F-02-21	26,8	109,5	103	71,0	76,0	26,5	13,5	11,13	M6	3x6	45	40,0	31,0	47	15,5	120°	42	30°	60°	O-ring 7,65x1,78	G1/8	3,2
68288	6951F-02-22	26,8	109,5	103	71,0	76,0	26,5	13,5	11,13	M6	3x6	45	40,0	31,0	47	15,5	120°	42	30°	60°	O-ring 7,65x1,78	G1/8	3,2
68346	6951F-05-21	38,0	145,0	135	92,5	97,0	25,0	15,0	15,88	M10	3x7	57	50,0	33,5	54	19,0	120°	50	55°	110°	O-ring 7,65x1,78	G1/8	4,8
68361	6951F-05-22	38,0	145,0	135	92,5	97,0	25,0	15,0	15,88	M10	3x7	57	50,0	33,5	54	19,0	120°	50	55°	110°	O-ring 7,65x1,78	G1/8	4,8
68411	6951F-11-21	45,4	186,0	173	112,5	118,5	28,5	16,5	22,23	M12	5x9	55	59,5	42,0	71	27,5	90°	62	22,5°	45°	O-ring 7,65x1,78	G1/4	4,8
68437	6951F-11-22	45,4	186,0	173	112,5	118,5	28,5	16,5	22,23	M12	5x9	55	59,5	42,0	71	27,5	90°	62	22,5°	45°	O-ring 7,65x1,78	G1/4	4,8

No. 6951G Swing Clamp, thread-flange-mounting

single and double acting,
max. operating pressure 350 bar,
min. operating pressure 40 bar.

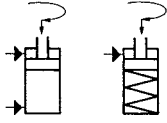

Order no.	Article no.	Clamp. force at 350 bar clamp* [kN]	Clamp. force at 350 bar unclamp* [kN]	Clamping stroke M [mm]	Total stroke N [mm]	Oil capacity clamp [cm ³]	Oil capacity unclamp [cm ³]	effective piston area clamp [cm ²]	effective piston area unclamp [cm ²]	Max. oil flow rate Q max. [l/min]	Weight [g]
68619	6951G-02-11	2	-	6	14,5	0,92	-	0,63	-	0,165	308
68635	6951G-02-12	2	-	6	14,5	0,92	-	0,63	-	0,165	308
68692	6951G-05-11	5	-	8	20,0	3,82	-	1,90	-	0,400	771
68718	6951G-05-12	5	-	8	20,0	3,82	-	1,90	-	0,400	771
68429	6951G-11-11	11	-	13	29,5	11,90	-	4,04	-	1,640	1424
68445	6951G-11-12	11	-	13	29,5	11,90	-	4,04	-	1,640	1424
68650	6951G-02-21	2	5,6	6	14,5	0,92	2,3	0,63	1,60	0,165	300
68676	6951G-02-22	2	5,6	6	14,5	0,92	2,3	0,63	1,60	0,165	300
68734	6951G-05-21	5	13,5	8	20,0	3,82	7,8	1,90	3,88	0,400	744
68759	6951G-05-22	5	13,5	8	20,0	3,82	7,8	1,90	3,88	0,400	744
68452	6951G-05-210	5	13,5	19	31,0	5,90	11,9	1,90	3,88	0,400	850
68478	6951G-05-220	5	13,5	19	31,0	5,90	11,9	1,90	3,88	0,400	850
68460	6951G-11-21	11	27,7	13	29,5	11,90	23,0	4,04	7,92	1,640	1379
68486	6951G-11-22	11	27,7	13	29,5	11,90	23,0	4,04	7,92	1,640	1379
68502	6951G-11-210	11	27,7	34	51,0	20,50	40,0	4,04	7,92	1,640	1941
68627	6951G-11-220	11	27,7	34	51,0	20,50	40,0	4,04	7,92	1,640	1941

* Clamping forces with short clamping arm.

Design:

Cylinder housing made of steel, hardened and blued. Piston rod case-hardened and chrome plated. Piston rod with internal thread. Wiper at piston rod. For single-acting models, return spring made of stainless steel. Clamp arm not included.

Application:

Swing clamps are used particularly in fixtures in which the workpiece must be freely accessible and placed from above. Workpieces with difficult shapes can also be clamped using special clamp arms (available on request).

Features:

Each cylinder size is available for single- or double-acting operation. Oil supply via threaded connection. The swing motion employs a patented ball-guide mechanism.

Note:

The piston is guided, and so the max. permissible oil flow rate Q max. as well as the clamping arm length and weight must be observed. When mounting accessories at the piston, no force may be applied to the piston. For single-acting cylinders, there is risk of sucking in coolant through the breather port. In such cases the breather port has to be moved to a clean protected area via a connection line. When installing, ensure that all air is bled from the system. Grooved nuts DIN 70852 can also be used for attachment.

Other swivel angles are available on request.

Dimensions

Order no.	Article no.	A	B	C	D	E	F	G	dia. H	J	P	R	dia. T	U	V	W	AD
68619	6951G-02-11	M28x1,5	108,0	102,0	44,0	30,5	25,5	13	11,13	M6	32,0	20,5	38,0	G1/8	25°	14,0	3,2
68635	6951G-02-12	M28x1,5	108,0	102,0	44,0	30,5	25,5	13	11,13	M6	32,0	20,5	38,0	G1/8	25°	14,0	3,2
68692	6951G-05-11	M38x1,5	143,0	134,0	60,0	36,0	31,0	13	15,88	M10	38,0	26,0	47,5	G1/8	35°	19,5	4,8
68718	6951G-05-12	M38x1,5	143,0	134,0	60,0	36,0	31,0	13	15,88	M10	38,0	26,0	47,5	G1/8	35°	19,5	4,8
68429	6951G-11-11	M48x1,5	185,0	172,0	79,0	38,0	32,0	13	22,23	M12	47,5	31,5	60,0	G1/4	30°	25,5	4,8
68445	6951G-11-12	M48x1,5	185,0	172,0	79,0	38,0	32,0	13	22,23	M12	47,5	31,5	60,0	G1/4	30°	25,5	4,8
68650	6951G-02-21	M28x1,5	108,0	102,0	44,0	30,5	25,5	13	11,13	M6	32,0	20,5	38,0	G1/8	25°	14,0	3,2
68676	6951G-02-22	M28x1,5	108,0	102,0	44,0	30,5	25,5	13	11,13	M6	32,0	20,5	38,0	G1/8	25°	14,0	3,2
68734	6951G-05-21	M38x1,5	143,0	134,0	60,0	36,0	31,0	13	15,88	M10	38,0	26,0	47,5	G1/8	35°	19,5	4,8
68759	6951G-05-22	M38x1,5	143,0	134,0	60,0	36,0	31,0	13	15,88	M10	38,0	26,0	47,5	G1/8	35°	19,5	4,8
68452	6951G-05-210	M38x1,5	176,5	167,0	82,5	35,5	31,0	13	15,88	M10	38,0	26,0	47,5	G1/8	35°	19,5	4,8
68478	6951G-05-220	M38x1,5	176,5	167,0	82,5	35,5	31,0	13	15,88	M10	38,0	26,0	47,5	G1/8	35°	19,5	4,8
68460	6951G-11-21	M48x1,5	185,0	172,0	79,0	38,0	32,0	13	22,23	M12	47,5	31,5	60,0	G1/4	30°	25,5	4,8
68486	6951G-11-22	M48x1,5	185,0	172,0	79,0	38,0	32,0	13	22,23	M12	47,5	31,5	60,0	G1/4	30°	25,5	4,8
68502	6951G-11-210	M48x1,5	249,0	235,5	121,5	38,0	32,0	13	22,23	M12	47,5	31,5	60,0	G1/4	30°	25,5	4,8
68627	6951G-11-220	M48x1,5	249,0	235,5	121,5	38,0	32,0	13	22,23	M12	47,5	31,5	60,0	G1/4	30°	25,5	4,8

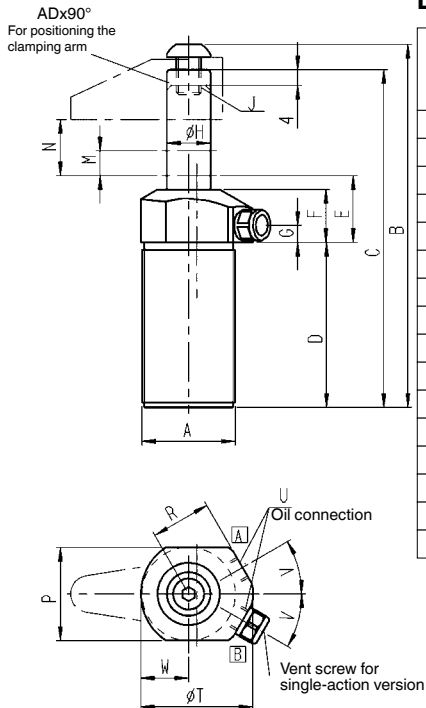

A = clamp
B = unclamp

No. 6951

Swing Clamp Arm, standard

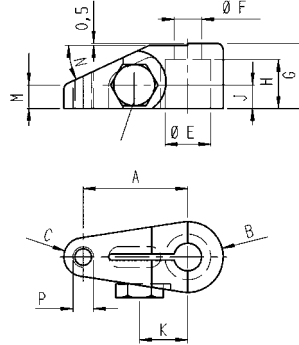

Dimensions

Order no.	Article no.	B	C	F	H	J	K	L	M	N	P
68973	6951-02-27	9,5	4,5	7,0	12,5	7,0	9,5	M6x1,00	6,5	22°	M6x1,00
68999	6951-05-38	12,5	6,5	10,5	18,0	8,0	12,7	M8x1,25	7,5	25°	M8x1,25
69070	6951-11-51	17,5	9,5	13,5	25,5	9,5	16,6	M10x1,25	12,0	25°	M10x1,50

Order no.	Article no.	for sizes	A [mm]	G [mm]	dia. E [mm]	Weight [g]
68973	6951-02-27	6951xx-02-xx	27	16	11,13 + 0,05	44
68999	6951-05-38	6951xx-05-xx	38	22	15,89 + 0,05	109
69070	6951-11-51	6951xx-11-xx	51	32	22,24 + 0,05	299

Design:

Tempered and blued steel.

Application:

For swing clamps No. 6951xx, size 02 to 11.

Note:

Clamping pressure, flow volume and clamping arm weight must be observed. Special versions available on request.

No. 6951

Swing Clamp Arm, upreach

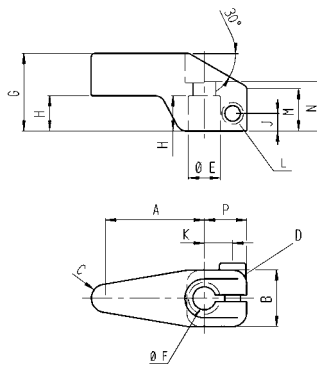

Dimensions

Order no.	Article no.	B	C	D	F	H	J	K	L	M	N	P
69112	6951-02-32	19,0	5,0	5,0	7,0	12,5	6,5	9,5	M6x1,00	12,5	16	16
69138	6951-05-44	25,5	6,5	6,5	10,5	18,0	8,0	12,5	M8x1,25	19,0	22	19
69153	6951-11-63	35,0	9,5	9,5	13,5	25,5	9,5	16,5	M10x1,25	26,5	32	26

Order no.	Article no.	for sizes	A [mm]	G [mm]	dia. E [mm]	Weight [g]
69112	6951-02-32	6951xx-02-xx	32,0	25,5	11,13 + 0,05	87
69138	6951-05-44	6951xx-05-xx	44,5	35,0	15,89 + 0,05	209
69153	6951-11-63	6951xx-11-xx	63,5	51,0	22,24 + 0,05	590

Design:

Tempered and blued steel.

Application:

For swing clamps No. 6951xx, size 02 to 11.

Note:

Clamping pressure, flow volume and clamping arm weight must be observed. Special versions available on request.

No. 6951

Swing Clamp Arm, long



Order no.	Article no.	for sizes	A [mm]	G [mm]	dia. E [mm]	Weight [g]
69229	6951-02-82	6951xx-02-xx	82,5	16	11,13 + 0,05	73
69245	6951-05-136	6951xx-05-xx	136,5	22	15,89 + 0,05	240
69260	6951-11-162	6951xx-11-xx	162,0	32	22,24 + 0,05	553

Design:

Tempered and blued steel.

Application:

For all swing clamps No. 6951xx, size 02 to 11 Clamping bars can be shortened to match the application..

Note:

Clamping pressure, flow volume and clamping arm weight must be observed. Special versions available on request.

Dimensions

Order no.	Article no.	B	C	D	F	H	J	K	L
69229	6951-02-82	26,0	10,5	8,5	7,0	12,5	7,0	9,5	M6x1,00
69245	6951-05-136	33,0	14,5	12,5	10,5	18,0	8,0	12,7	M8x1,25
69260	6951-11-162	50,5	19,0	16,0	13,5	25,5	9,5	16,6	M10x1,25

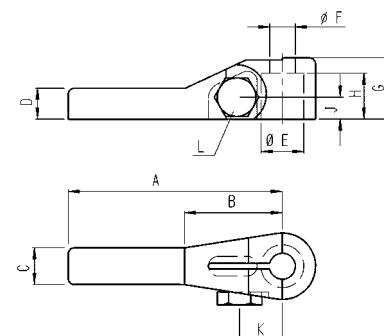

No. 6951 Swing Clamp Arm, double ended



Order no.	Article no.	for sizes	2A	G [mm]	dia. E [mm]	Weight [g]
69252	6951-02-140	6951xx-02-xx	140	16	11,13 + 0,05	118
69278	6951-05-222	6951xx-05-xx	222	22	15,89 + 0,05	354
69294	6951-11-272	6951xx-11-xx	272	32	22,24 + 0,05	801

Design:

Tempered and blued steel.

Application:

For all swing clamps No. 6951xx, size 02 to 11 Clamping bars can be shortened to match the application..

Note:

Clamping pressure, flow volume and clamping arm weight must be observed. It is also essential that clamping or support heights in either side are identical. Special versions available on request.

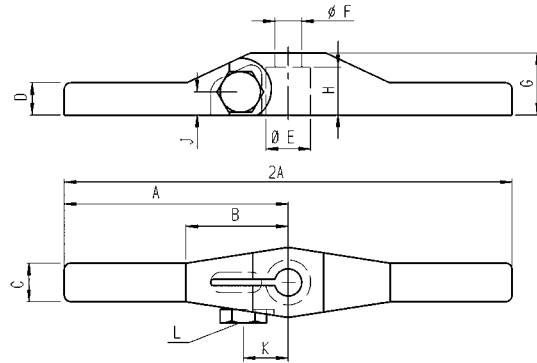

Dimensions

Order no.	Article no.	A	B	C	D	F	H	J	K	L
69252	6951-02-140	70	26,0	10,5	8,5	7,0	12,5	7,0	9,5	M6x1,00
69278	6951-05-222	111	33,0	14,5	12,5	10,5	18,0	8,0	12,7	M8x1,25
69294	6951-11-272	136	50,5	19,0	16,0	13,5	25,5	9,5	16,6	M10x1,25

No. 6951WN Swing Clamp arm, double-ended pivoted



Order no.	Article no.	for sizes	W max.	2A	dia. E	Weight [g]
320457	6951WN-02-100	6951xx-02-xx	6°	100	11,2	150
320465	6951WN-05-150	6951xx-05-xx	6°	150	15,9	440

Design:

Steel, blued. Clamping arm tempered.

Application:

For all Series 6951 swing clamps. Used for clamping two workpieces with slightly different heights.

Note:

Clamping pressure and maximum tilt angle (W) must not be exceeded. Special versions are available on request.

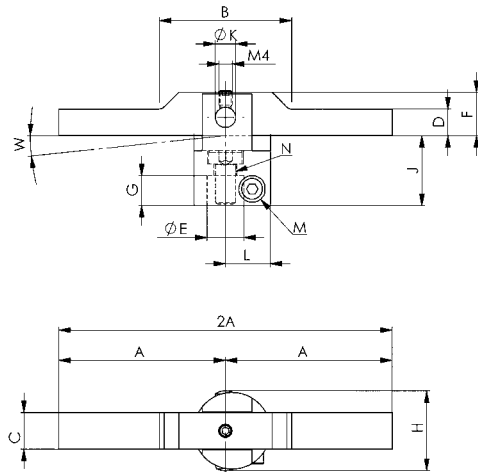

Dimensions

Order no.	Article no.	B	C	D	F	G	H	J	ØK	L	M	N
320457	6951WN-02-100	39	11	8	13	9	24	21	6	13,5	M4	M6
320465	6951WN-05-150	52	16	12	19	15	35	31	8	19,5	M6	M10

No. 6951

Dimensions for proprietary manufacturing of clamping arms

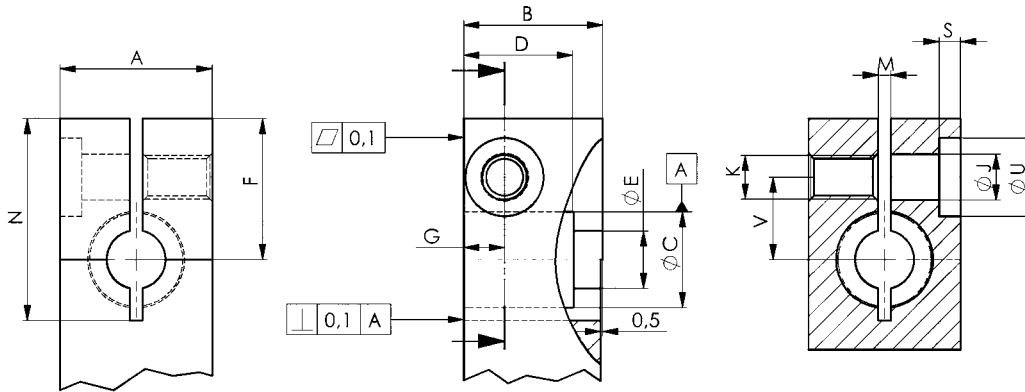

Toleranz DIN ISO 2768 m

Important note:

Lever lengths and lever weights (see no. 6951-xx above) must be observed!

Dimensions (proprietary manufacture)

for cylinder size	A	B	dia.C +0,05	D	dia.E	F	G	dia.J	K	M	N	S	dia.U	V
-02	70	26,0	10,5	8,5	7,0	12,5	7,0	9,5	M 6	7,0	12,5	7,0	9,5	M 6
-05	111	33,0	14,5	12,5	10,5	18,0	8,0	12,7	M 8	10,5	18,0	8,0	12,7	M 8
-11	136	50,5	19,0	16,0	13,5	25,5	9,5	16,6	M10	13,5	25,5	9,5	16,6	M10

No. 6916-12

Throttle/Check Valve

max. operating pressure 350 bar.

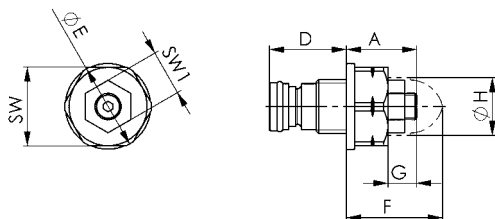

Order no.	Article no.	Pressure max. [bar]	Throttle direction	Threaded connection	Weight [g]
326579	6916-12-01	350	A-B	G1/8	45
326611	6916-12-04	350	A-B	G1/4	45

Design:

Housing made of steel, hardened and blued. Compact size. Throttle as flow control.

Application:

For single- and double-acting swing clamps 6951F and 6951K. The swing speed can be set by regulating the flow. The swing mechanism must be protected from pressure peaks.

Note:

The cartridge valve is inserted in the external threaded ports and is only suitable for use with swing clamps with an O-ring manifold connection for operation.

These valves must only be used with AMF swing clamps and are not suitable for any other device.

Dimensions

Order no.	Article no.	A max.	D	E	F	G	H	SW	SW1
326579	6916-12-01	13	15,16	15,5	22,8	5,3	14	14	11
326611	6916-12-04	13	18,72	21,0	23,3	5,3	14	19	11

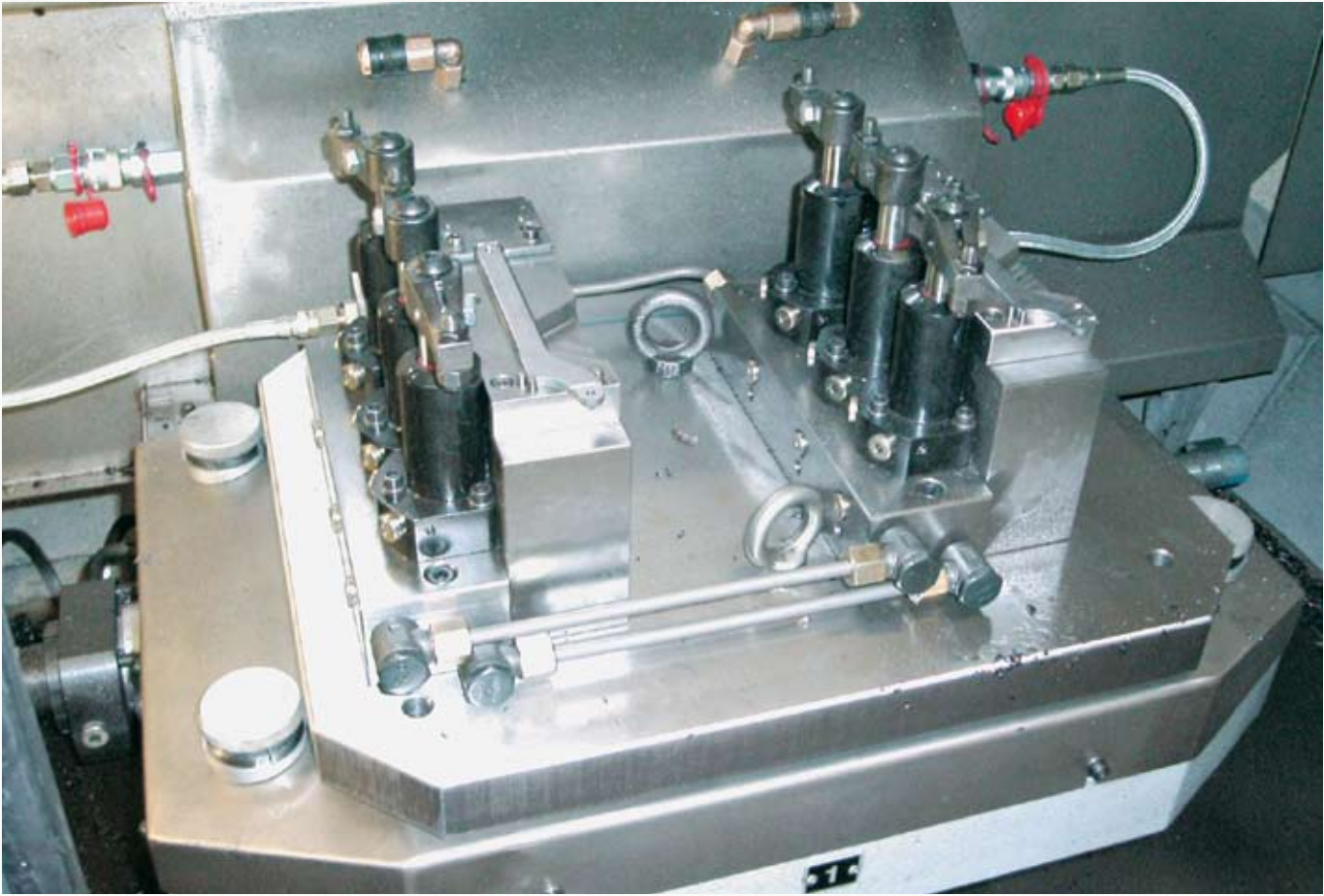

Subject to technical alterations.

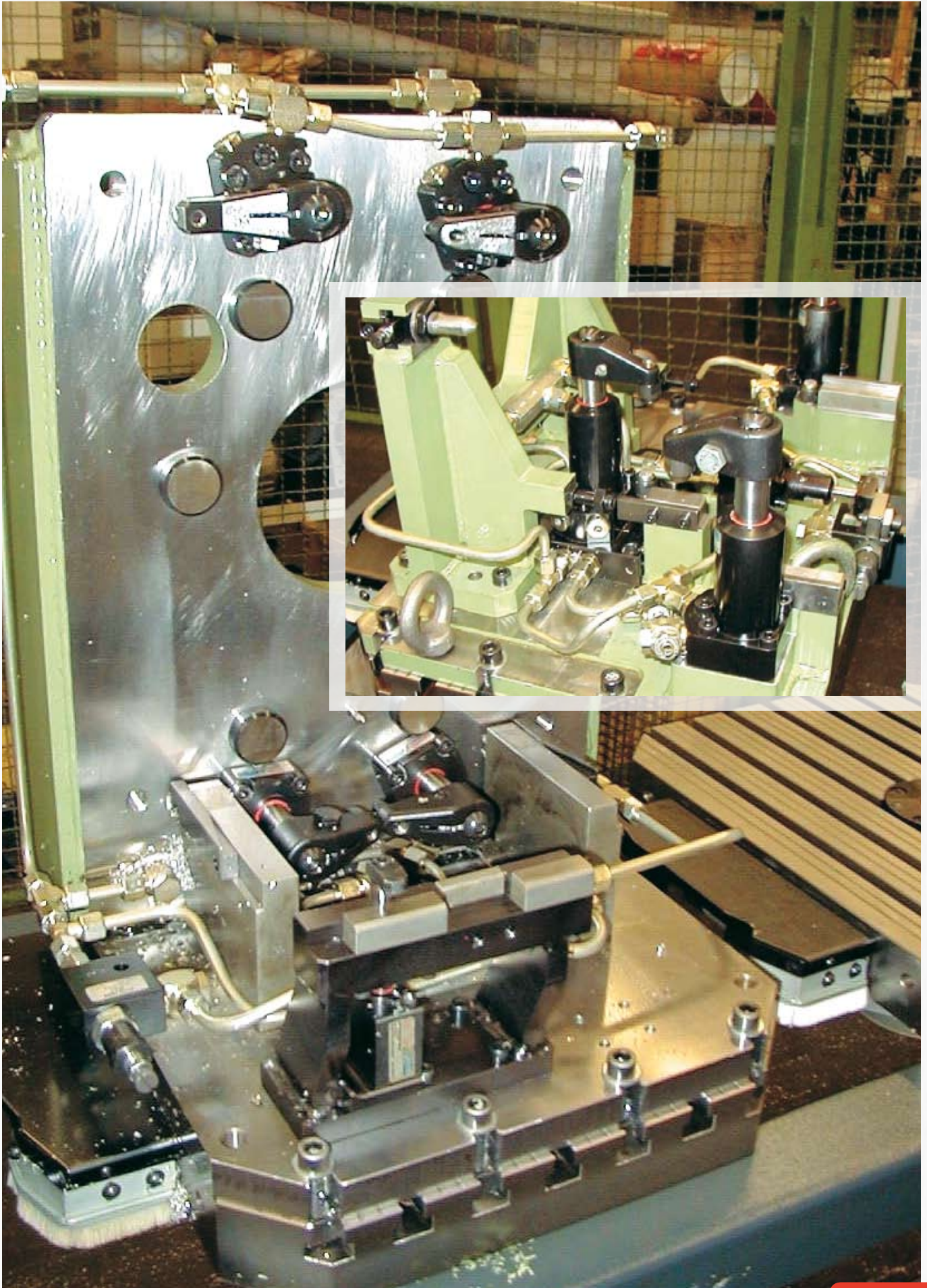

No. 6951KN

Swing Clamp, top-flange-mounting

single acting,
max. operating pressure 350 bar,
min. operating pressure 40 bar.

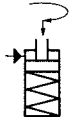

Order no.	Article no.	Clamping force at 350 bar* [kN]	Clamping stroke M [mm]	Total stroke L [mm]	Oil capacity [cm ³]	effective piston area [cm ²]	Max. oil flow rate Q max. [l/min]	Weight [g]
69369	6951KN-22-11	22	13,0	28	21,0	7,6	2,5	2550
69385	6951KN-22-12	22	13,0	28	21,0	7,6	2,5	2550
65888	6951KN-33-11	33	14,7	30	34,3	11,4	2,5	3992
65896	6951KN-33-12	33	14,7	30	34,3	11,4	2,5	3992

* Clamping forces with short clamping arm.

Design:

Cylinder housing made of steel, hardened and blued. Piston rod case-hardened and chrome plated. Wiper at piston rod. Return spring made of stainless steel. Clamp arm not included.

Application:

The swing clamp is used particularly in fixtures in which the workpieces must be freely accessible and placed from above. Workpieces with difficult shapes can also be clamped using special clamp arms (available on request).

Features:

Oil supply via threaded connection or oil channel in the fixture body. The swing motion employs a ball guide mechanism.

Note:

The piston is guided, and so the max. permissible oil flow rate Q max. as well as the clamping arm length and weight must be observed. When mounting accessories at the piston, no force may be applied to the piston. For single-acting cylinders, there is risk of sucking in coolant through the breather port. In such cases the breather port has to be moved to a clean protected area via a connection line. When installing, ensure that all air is bled from the system.

Replacement O-ring for flange connection is available under Order No. 183608. Other swivel angles are available on request.

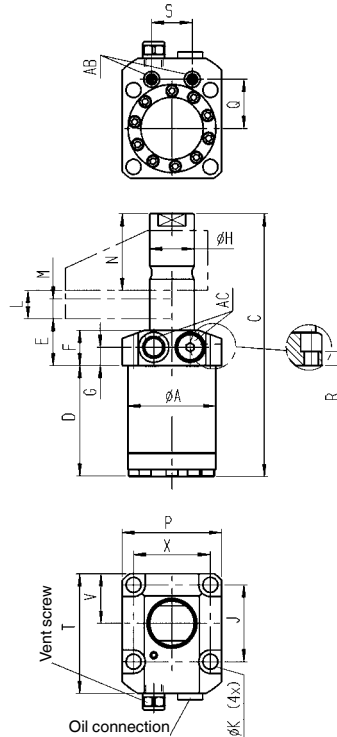

Dimensions

Order no.	Article no.	A	C	D	E	F	G	H	J	K	N	P	Q	R	S	T	V	X	AB	AC
69369	6951KN-22-11	62,8	196	79,5	33	25	13	31,75	55	10,7	55	70	35,0	12,8	29,1	85	35,0	55	O-ring 7,65x1,78	G 1/4
69385	6951KN-22-12	62,8	196	79,5	33	25	13	31,75	55	10,7	55	70	35,0	12,8	29,1	85	35,0	55	O-ring 7,65x1,78	G 1/4
65888	6951KN-33-11	77,0	216	89,0	33	25	13	38,10	70	13,5	64	89	40,6	12,3	35,6	100	44,5	70	O-ring 7,65x1,78	G 1/4
65896	6951KN-33-12	77,0	216	89,0	33	25	13	38,10	70	13,5	64	89	40,6	12,3	35,6	100	44,5	70	O-ring 7,65x1,78	G 1/4

No. 6951KN

Swing Clamp, top-flange-mounting

double acting,
max. operating pressure 350 bar,
min. operating pressure 40 bar.

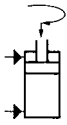

Order no.	Article no.	Clamp. force at 350 bar clamp* [kN]	Clamp. force at 350 bar unclamp* [kN]	Clamping stroke M [mm]	Total stroke L [mm]	Oil capacity clamp [cm ³]	Oil capacity unclamp [cm ³]	effective piston area clamp [cm ²]	effective piston area unclamp [cm ²]	Max. oil flow rate Q max. [l/min]	Weight [g]
69401	6951KN-22-21	22	54	13,0	28,0	21,0	43,0	7,6	15,5	2,5	2590
69427	6951KN-22-22	22	54	13,0	28,0	21,0	43,0	7,6	15,5	2,5	2590
61903	6951KN-22-210**	22	54	32,0	45,5	34,9	71,3	7,6	15,5	2,5	2948
61929	6951KN-22-220**	22	54	32,0	45,5	34,9	71,3	7,6	15,5	2,5	2948
65912	6951KN-33-21	33	80	14,7	30,0	34,3	68,6	11,4	22,8	2,5	4355
65920	6951KN-33-22	33	80	14,7	30,0	34,3	68,6	11,4	22,8	2,5	4355
61861	6951KN-33-210**	33	80	30,5	45,5	52,4	104,7	11,4	22,8	2,5	4881
61887	6951KN-33-210**	33	80	30,5	45,5	52,4	104,7	11,4	22,8	2,5	4881

* Clamping forces with short clamping arm.

** Not a stock item!

Design:

Cylinder housing made of steel, hardened and blued. Piston rod case-hardened and chrome plated. Wiper at piston rod. Clamp arm not included.

Application:

The swing clamp is used particularly in fixtures in which the workpieces must be freely accessible and placed from above. Workpieces with difficult shapes can also be clamped using special clamp arms (available on request).

Features:

Oil supply via threaded connection or oil channel in the fixture body. The swing motion employs a ball guide mechanism.

Note:

The piston is guided, and so the max. permissible oil flow rate Q max. as well as the clamping arm length and weight must be observed. When mounting accessories at the piston, no force may be applied to the piston. When installing, ensure that all air is bled from the system.

Replacement O-ring for flange connection is available under Order No. 183608. Other swivel angles are available on request.

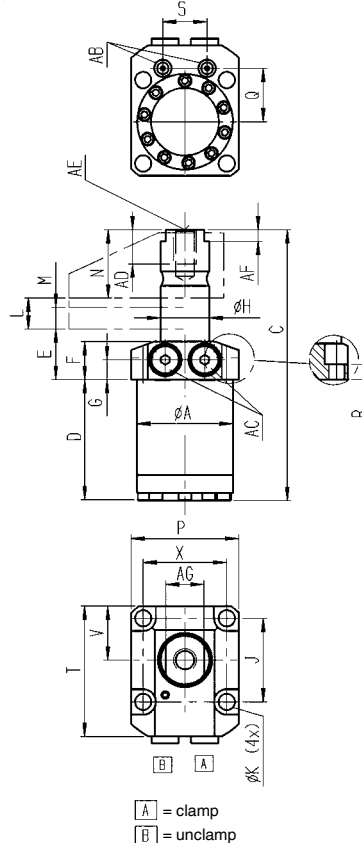

Dimensions

Order no.	Article no.	A	C	D	E	F	G	H	J	K	N	P	Q	R	S	T	V	X	AB	AC	AD	AE	AF	AG
69401	6951KN-22-21	62,8	185,6	79,5	33	25	13	31,75	55	10,7	45	70	35,0	12,8	29,1	85	35,0	55	O-ring 7,65x1,78	G1/4	19	M16	12,7	27
69427	6951KN-22-22	62,8	185,6	79,5	33	25	13	31,75	55	10,7	45	70	35,0	12,8	29,1	85	35,0	55	O-ring 7,65x1,78	G1/4	19	M16	12,7	27
61903	6951KN-22-210**	62,8	218,0	97,0	33	25	13	31,75	55	10,7	45	70	35,0	12,8	29,1	85	35,0	55	O-ring 7,65x1,78	G1/4	19	M16	12,7	27
61929	6951KN-22-220**	62,8	218,0	97,0	33	25	13	31,75	55	10,7	45	70	35,0	12,8	29,1	85	35,0	55	O-ring 7,65x1,78	G1/4	19	M16	12,7	27
65912	6951KN-33-21	77,0	196,6	89,0	33	25	13	38,10	70	13,5	45	89	40,6	12,3	35,6	100	44,5	70	O-ring 7,65x1,78	G1/4	19	M16	12,7	33
65920	6951KN-33-22	77,0	196,6	89,0	33	25	13	38,10	70	13,5	45	89	40,6	12,3	35,6	100	44,5	70	O-ring 7,65x1,78	G1/4	19	M16	12,7	33
61861	6951KN-33-210**	77,0	228,0	104,8	33	25	13	38,10	70	13,5	45	89	40,6	12,3	35,6	100	44,5	70	O-ring 7,65x1,78	G1/4	19	M16	12,7	33
61887	6951KN-33-210**	77,0	228,0	104,8	33	25	13	38,10	70	13,5	45	89	40,6	12,3	35,6	100	44,5	70	O-ring 7,65x1,78	G1/4	19	M16	12,7	33

No. 6951FN

Swing Clamp, base-flange-mounting

single acting,
max. operating pressure 350 bar,
min. operating pressure 40 bar.

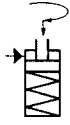

Order no.	Article no.	Clamping force at 350 bar* [kN]	Clamping stroke M [mm]	Total stroke L [mm]	Oil capacity [cm ³]	effective piston area [cm ²]	Max. oil flow rate Q max. [l/min]	Weight [g]
69443	6951FN-22-11	22	13,0	28	21,0	7,6	2,5	3030
69468	6951FN-22-12	22	13,0	28	21,0	7,6	2,5	3030
62224	6951FN-33-11	33	14,7	30	34,3	11,4	2,5	4854
65987	6951FN-33-12	33	14,7	30	34,3	11,4	2,5	4854

* Clamping forces with short clamping arm.

Design:

Cylinder housing made of steel, hardened and blued. Piston rod case-hardened and chrome plated. Wiper at piston rod. Return spring made of stainless steel. Clamp arm not included.

Application:

The swing clamp is used particularly in fixtures in which the workpieces must be freely accessible and placed from above. Workpieces with difficult shapes can also be clamped using special clamp arms (available on request).

Features:

Oil supply via threaded connection or oil channel in the fixture body. The swing motion employs a ball guide mechanism.

Note:

The piston is guided, and so the max. permissible oil flow rate Q max. as well as the clamping arm length and weight must be observed. When mounting accessories at the piston, no force may be applied to the piston. For single-acting cylinders, there is risk of sucking in coolant through the breather port. In such cases the breather port has to be moved to a clean protected area via a connection line. When installing, ensure that all air is bled from the system.

Replacement O-ring for flange connection available on request under Order No. 183608. Other swivel angles are available on request.

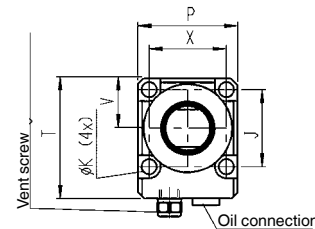
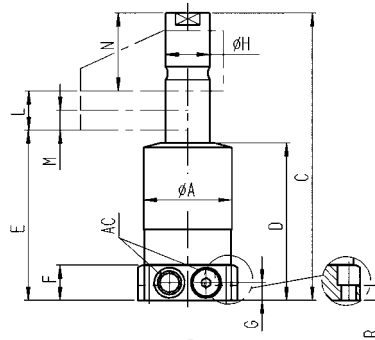
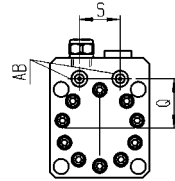

Dimensions

Order no.	Article no.	A	C	D	E	F	G	H	J	K	N	P	Q	R	S	T	V	X	AB	AC
69443	6951FN-22-11	62,8	204	112,0	121,0	25	13	31,75	55	10,7	55	70	35,0	13,2	29,1	85	35,0	55	O-ring 7,65x1,78	G1/4
69468	6951FN-22-12	62,8	204	112,0	121,0	25	13	31,75	55	10,7	55	70	35,0	13,2	29,1	85	35,0	55	O-ring 7,65x1,78	G1/4
62224	6951FN-33-11	79,1	225	121,4	130,6	25	13	38,10	70	13,5	64	89	41,7	12,3	34,5	100	44,4	70	O-ring 7,65x1,78	G1/4
65987	6951FN-33-12	79,1	225	121,4	130,6	25	13	38,10	70	13,5	64	89	41,7	12,3	34,5	100	44,4	70	O-ring 7,65x1,78	G1/4

Subject to technical alterations.

No. 6951FN

Swing Clamp, base-flange-mounting

double acting,
max. operating pressure 350 bar,
min. operating pressure 40 bar.

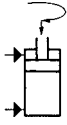

Order no.	Article no.	Clamp. force at 350 bar clamp* [kN]	Clamp. force at 350 bar unclamp* [kN]	Clamping stroke M [mm]	Total stroke L [mm]	Oil capacity clamp [cm ³]	Oil capacity unclamp [cm ³]	effective piston area clamp [cm ²]	effective piston area unclamp [cm ²]	Max. oil flow rate Q max. [l/min]	Weight [g]
69484	6951FN-22-21	22	54	13,0	28	21,0	43,0	7,6	15,5	2,5	3070
69492	6951FN-22-22	22	54	13,0	28	21,0	43,0	7,6	15,5	2,5	3070
66290	6951FN-33-21	33	80	14,7	30	34,3	68,6	11,4	22,8	2,5	4854
66332	6951FN-33-22	33	80	14,7	30	34,3	68,6	11,4	22,8	2,5	4854

* Clamping forces with short clamping arm.

Design:

Cylinder housing made of steel, hardened and blued. Piston rod case-hardened and chrome plated. Wiper at piston rod. Clamp arm not included.

Application:

The swing clamp is used particularly in fixtures in which the workpieces must be freely accessible and placed from above. Workpieces with difficult shapes can also be clamped using special clamp arms (available on request).

Features:

Oil supply via threaded connection or oil channel in the fixture body. The swing motion employs a ball guide mechanism.

Note:

The piston is guided, and so the max. permissible oil flow rate Q max. as well as the clamping arm length and weight must be observed. When mounting accessories at the piston, no force may be applied to the piston. When installing, ensure that all air is bled from the system.

Replacement O-ring for flange connection available on request under Order No. 183608. Other swivel angles are available on request.

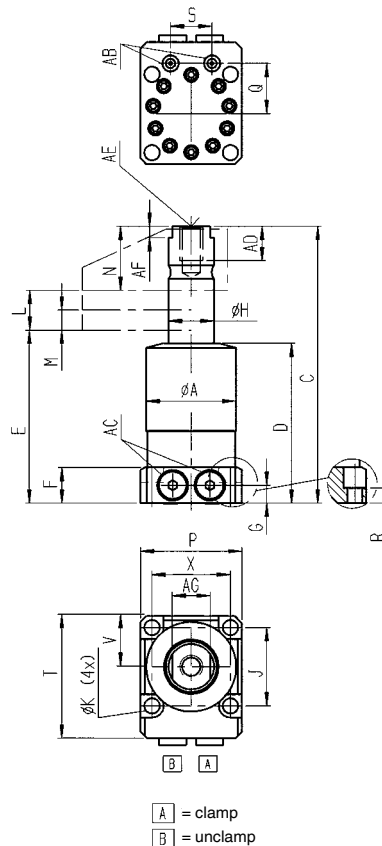

Dimensions

Order no.	Article no.	A	C	D	E	F	G	H	J	K	N	P	Q	R	S	T	V	X	AB	AC	AD	AE	AF	AG
69484	6951FN-22-21	62,8	194	112,0	121,0	25	13	31,75	55	10,7	45	70	35,0	13,2	29,1	85	35,0	55	O-ring 7,65x1,78	G1/4	19	M16	12,7	27
69492	6951FN-22-22	62,8	194	112,0	121,0	25	13	31,75	55	10,7	45	70	35,0	13,2	29,1	85	35,0	55	O-ring 7,65x1,78	G1/4	19	M16	12,7	27
66290	6951FN-33-21	79,1	205	121,4	130,6	25	13	38,10	70	13,5	45	89	41,7	12,3	34,5	100	44,4	70	O-ring 7,65x1,78	G1/4	19	M16	12,7	33
66332	6951FN-33-22	79,1	205	121,4	130,6	25	13	38,10	70	13,5	45	89	41,7	12,3	34,5	100	44,4	70	O-ring 7,65x1,78	G1/4	19	M16	12,7	33

No. 6951GN

Swing Clamp, thread-flange-mounting

single acting,
max. operating pressure 350 bar,
min. operating pressure 40 bar.

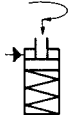

Order no.	Article no.	Clamping force at 350 bar* [kN]	Clamping stroke K [mm]	Total stroke J [mm]	Oil capacity [cm ³]	effective piston area [cm ²]	Max. oil flow rate Q max. [l/min]	Weight [g]
69757	6951GN-22-11	22	13,0	28	21,0	7,6	2,5	2550
69773	6951GN-22-12	22	13,0	28	21,0	7,6	2,5	2550
69476	6951GN-33-11	33	14,7	30	34,4	11,4	2,5	3947
69963	6951GN-33-12	33	14,7	30	34,4	11,4	2,5	3947

* Clamping forces with short clamping arm.

Design:

Cylinder housing made of steel, hardened and blued. Piston rod case-hardened and chrome plated. Wiper at piston rod. Return spring made of stainless steel. Clamp arm not included.

Application:

The swing clamp is used particularly in fixtures in which the workpieces must be freely accessible and placed from above. Workpieces with difficult shapes can also be clamped using special clamp arms (available on request).

Features:

Oil supply via threaded connection. The swing motion employs a ball guide mechanism.

Note:

The piston is guided, and so the max. permissible oil flow rate Q max. as well as the clamping arm length and weight must be observed. When mounting accessories at the piston, no force may be applied to the piston. For single-acting cylinders, there is risk of sucking in coolant through the breather port. In such cases the breather port has to be moved to a clean protected area via a connection line. When installing, ensure that all air is bled from the system.

Other swivel angles are available on request. Grooved nuts DIN 70852 can also be used for attachment.

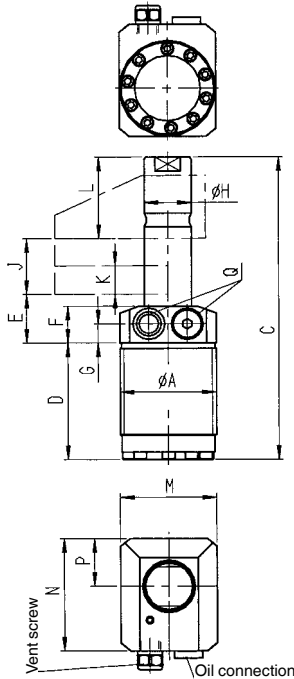

Dimensions

Order no.	Article no.	A	C	D	E	F	G	H	L	M	N	P	Q
69757	6951GN-22-11	M65x1,5	196	79,5	33	25	13	31,75	55	65	76,0	32,5	G1/4
69773	6951GN-22-12	M65x1,5	196	79,5	33	25	13	31,75	55	65	76,0	32,5	G1/4
69476	6951GN-33-11	M80x2,0	216	80,8	33	25	13	38,10	64	80	88,4	40,0	G1/4
69963	6951GN-33-12	M80x2,0	216	80,8	33	25	13	38,10	64	80	88,4	40,0	G1/4

No. 6951GN

Swing Clamp, thread-flange-mounting

double acting,
max. operating pressure 350 bar,
min. operating pressure 40 bar.

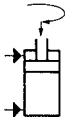

Order no.	Article no.	Clamp. force at 350 bar clamp* [kN]	Clamp. force at 350 bar unclamp* [kN]	Clamping stroke K [mm]	Total stroke J [mm]	Oil capacity clamp [cm ³]	Oil capacity unclamp [cm ³]	effective piston area clamp [cm ²]	effective piston area unclamp [cm ²]	Max. oil flow rate Q max. [l/min]	Weight [g]
69765	6951GN-22-21	22	54	13,0	28	21,0	43,0	7,6	15,5	2,5	2590
69781	6951GN-22-22	22	54	13,0	28	21,0	43,0	7,6	15,5	2,5	2590
69120	6951GN-33-21	33	80	14,7	30	34,4	68,6	11,4	22,8	2,5	4174
65805	6951GN-33-22	33	80	14,7	30	34,4	68,6	11,4	22,8	2,5	4174

* Clamping forces with short clamping arm.

Design:

Cylinder housing made of steel, hardened and blued. Piston rod case-hardened and chrome plated. Wiper at piston rod. Clamp arm not included.

Application:

The swing clamp is used particularly in fixtures in which the workpieces must be freely accessible and placed from above. Workpieces with difficult shapes can also be clamped using special clamp arms (available on request).

Features:

Oil supply via threaded connection. The swing motion employs a ball guide mechanism.

Note:

The piston is guided, and so the max. permissible oil flow rate Q max. as well as the clamping arm length and weight must be observed. When mounting accessories at the piston, no force may be applied to the piston. When installing, ensure that all air is bled from the system.

Other swivel angles are available on request. Grooved nuts DIN 70852 can also be used for attachment.

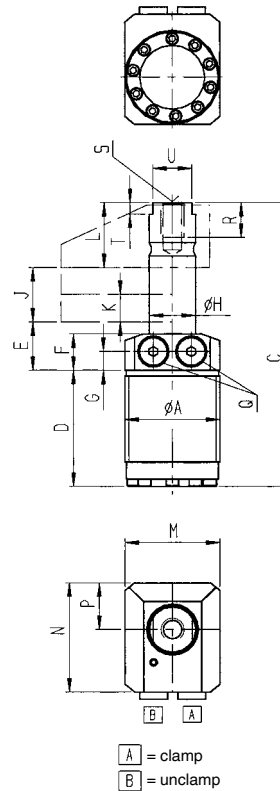

Dimensions

Order no.	Article no.	A	C	D	E	F	G	H	L	M	N	P	Q	R	S	T	U
69765	6951GN-22-21	M65x1,5	185,6	79,5	33	25	13	31,75	45	65	76,0	32,5	G1/4	19	M16	12,7	27
69781	6951GN-22-22	M65x1,5	185,6	79,5	33	25	13	31,75	45	65	76,0	32,5	G1/4	19	M16	12,7	27
69120	6951GN-33-21	M80x2,0	196,6	88,9	33	25	13	38,10	45	80	88,4	40,0	G1/4	19	M16	12,7	33
65805	6951GN-33-22	M80x2,0	196,6	88,9	33	25	13	38,10	45	80	88,4	40,0	G1/4	19	M16	12,7	33

No. 6951N Swing Clamp Arm, standard



Order no.	Article no.	for sizes	A [mm]	F [mm]	dia. E [mm]	Weight [g]
69146	6951N-22-63	6951N-22-xx	63,5	44,5	31,75 +0,05	801
60848	6951N-33-68	6951N-33-xx	68,0	44,5	38,11 +0,05	1134

Design:

Tempered and blued steel.

Application:

For swing clamps No. 6951KN/FN/GN.

Note:

Clamping pressure, flow volume and clamping arm weight must be observed. Special versions available on request.

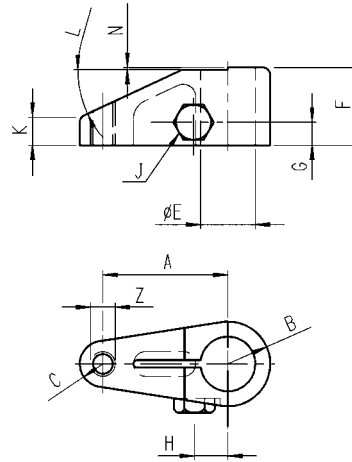

Dimensions

Order no.	Article no.	B	C	G	H	J	K	L	N	Z
69146	6951N-22-63	25,5	14,5	12,5	22,5	M16x1,5	16,0	25°	0,05	M12
60848	6951N-33-68	35,0	14,2	14,2	25,6	M16x1,5	16,4	25°	-	M16

No. 6951N Swing Clamp Arm, upreach



Order no.	Article no.	for sizes	A [mm]	F [mm]	dia. E [mm]	Weight [g]
69500	6951N-22-76	6951N-22-xx	76	70,0	31,75 +0,05	1580
61879	6951N-33-81	6951N-33-xx	81	76,2	38,11 +0,05	2313

Design:

Tempered and blued steel.

Application:

For swing clamps No. 6951KN/FN/GN.

Note:

Clamping pressure, flow volume and clamping arm weight must be observed. Special versions available on request.

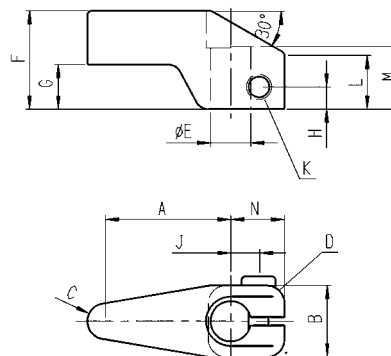

Dimensions

Order no.	Article no.	B	C	D	G	H	J	K	L	M	N
69500	6951N-22-76	51	14,5	14,5	36,5	13,5	22,5	M16x1,5	38	44,5	38,0
61879	6951N-33-81	70	14,3	14,3	39,6	13,5	25,6	M16x1,5	45	44,5	41,3

No. 6951N Swing Clamp Arm, long



Order no.	Article no.	for sizes	A [mm]	F [mm]	dia. E [mm]	Weight [g]
69161	6951N-22-165	6951N-22-xx	165,0	44,5	31,75 +0,05	1161
60855	6951N-22-165	6951N-33-xx	180,3	44,5	38,11 +0,05	1996

Design:

Tempered and blued steel.

Application:

For swing clamps No. 6951KN/FN/GN.

Note:

Clamping pressure, flow volume and clamping arm weight must be observed. Clamp arms can be shortened where necessary. Special versions available on request.

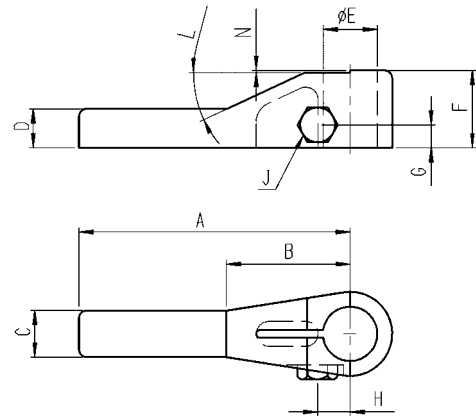

Dimensions

Order no.	Article no.	B	C	D	G	H	J	N	L
69161	6951N-22-165	70,5	28,5	19	12,5	22,4	M16x1,5	0,05	25°
60855	6951N-22-165	45,0	30,0	34	14,2	25,5	M16x1,5	-	25°

No. 6951N Swing Clamp Arm, double ended



Order no.	Article no.	for sizes	A [mm]	F [mm]	dia. E [mm]	Weight [g]
69526	6951N-22-280	6951N-22-xx	140,0	44,5	31,75 +0,05	1869
60863	6951N-33-360	6951N-33-xx	180,3	44,5	38,11 +0,05	3311

Design:

Tempered and blued steel.

Application:

For swing clamps No. 6951KN/FN/GN.

Note:

Clamping pressure, flow volume and clamping arm weight must be observed. Clamp arms can be shortened where necessary. It is also essential that clamping or support heights in either side are identical. Special versions available on request.

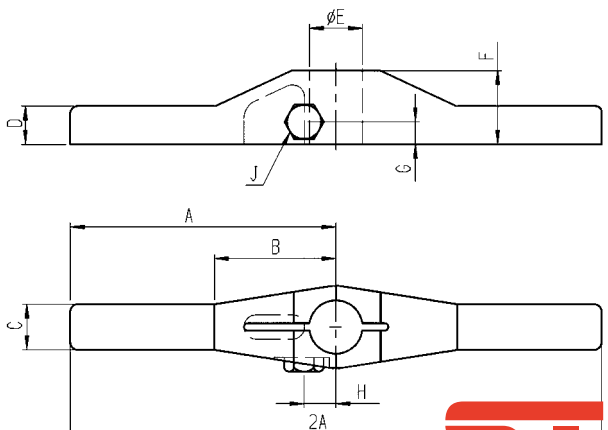

Dimensions

Order no.	Article no.	2A	B	C	D	G	H	J
69526	6951N-22-280	280,0	70,5	28,5	19	12,5	22,4	M16x1,5
60863	6951N-33-360	360,7	44,6	30,0	34	14,2	25,5	M16x1,5

No. 6951WN

Swing Clamp arm, double-ended

pivoted



Order no.	Article no.	for sizes	W max.	2A	dia. E	Weight [g]
320473	6951WN-11-180	6951xx-11-xx	6°	180	22,3	880
320481	6951WN-22-200	6951xx-22-xx	6°	200	31,8	1800
320499	6951WN-33-250	6951xx-33-xx	6°	250	38,2	3100

Design:

Steel, blued. Clamping arm tempered.

Application:

For all Series 6951 swing clamps. Used for clamping two workpieces with slightly different heights.

Note:

Clamping pressure and maximum tilt angle (W) must not be exceeded. Special versions are available on request.

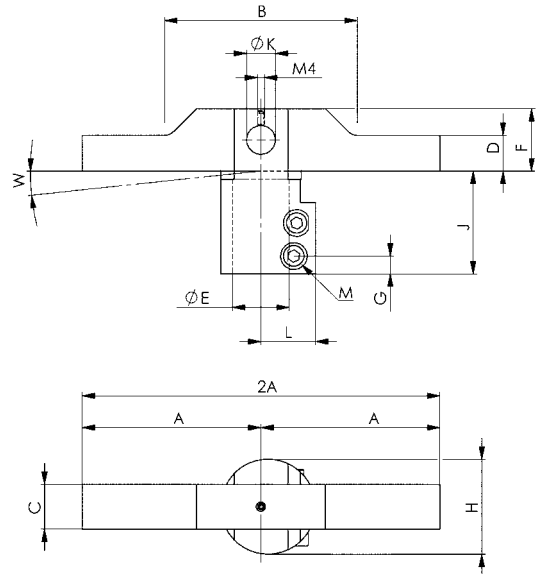

Dimensions

Order no.	Article no.	B	C	D	F	G	H	J	dia. K	L	M
320473	6951WN-11-180	74	19	16	28	19	40	38,0	12	25,0	M6
320481	6951WN-22-200	107	25	20	35	10	55	57,5	16	30,5	M8
320499	6951WN-33-250	125	33	22	38	10	65	64,5	20	36,0	M10

No. 6951

Dimensions for proprietary manufacturing of clamping arms

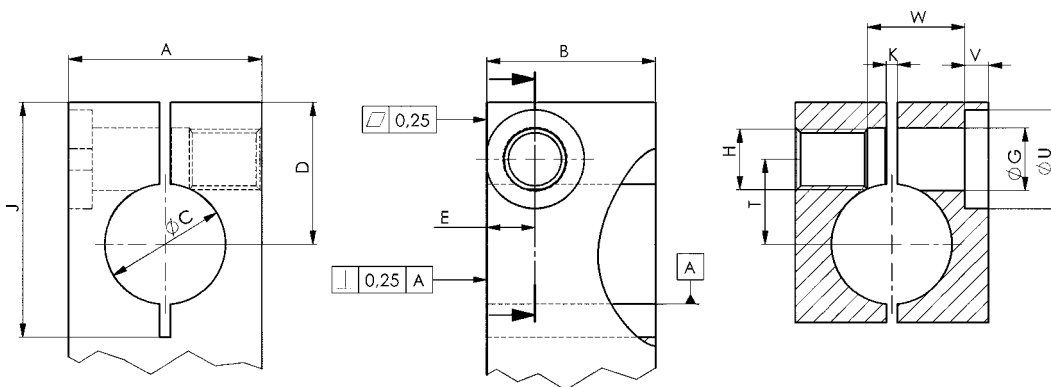

Toleranz DIN ISO 2768 m

Important note:

Lever lengths and lever weights must be observed!

Dimensions (proprietary manufacture)

for cylinder size	A	B	dia.C +0,025	D	E	dia.G	H	J	K	T	U	V	W
-22	51	44,5	31,775	37,4	12,5	16,5	M16x1,50-6H	59	2,93	22,4	26	6,2	25,7
-33	70	44,5	38,138	40,4	14,2	16,5	M16x1,50-6H	65	3,23	25,5	26	9,6	35,5

Subject to technical alterations.

Size 02				
Clamping arm length	mm	27	51	76
Max. clamping pressure	bar	350	183	122
Clamping force	kN	2	0,8	0,44
Output flow	l/min.	0,165	0,1	0,1
Max. clamping-arm weight	g	118		
Spring force*	N	78		

* single-acting version

Size 05				
Clamping arm length	mm	38	76	127
Max. clamping pressure	bar	350	176	107
Clamping force	kN	5	2,2	0,88
Output flow	l/min.	0,4	0,35	0,35
Max. clamping-arm weight	g	354		
Spring force*	N	210		

* single-acting version

Size 11				
Clamping arm length	mm	51	101,5	152
Max. clamping pressure	bar	350	177	119
Clamping force	kN	11	5,1	3,0
Output flow	l/min.	1,64	1,3	1,3
Max. clamping-arm weight	g	807		
Spring force*	N	696		

* single-acting version

Size 22				
Clamping arm length	mm	63,5	101,5	152
Max. clamping pressure	bar	350	192	138
Clamping force	kN	22	10	6,7
Output flow	l/min.	2,5	1,8	1,8
Max. clamping-arm weight	g	1869		
Spring force*	N	943		

* single-acting version

Size 33				
Clamping arm length	mm	68	101,5	178
Max. clamping pressure	bar	350	233	133
Clamping force	kN	33,4	22,2	12
Output flow	l/min.	2,5	1,7	1,0
Max. clamping-arm weight	g	3311		
Spring force*	N	1188		

* single-acting version

DIAGRAM DESCRIPTION:

The diagrams show the maximum operating pressure in relation to the clamping arm length and the resulting clamping force.

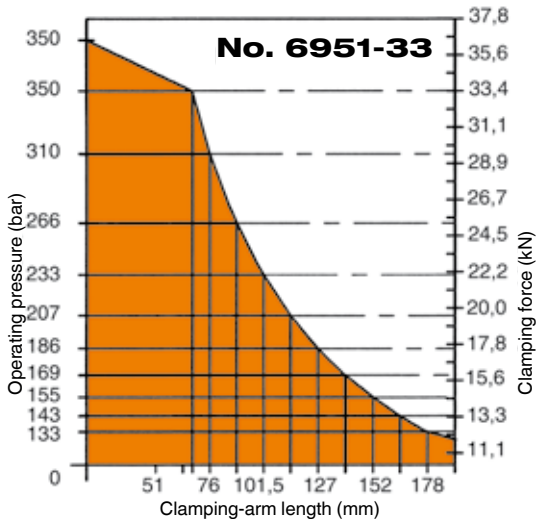
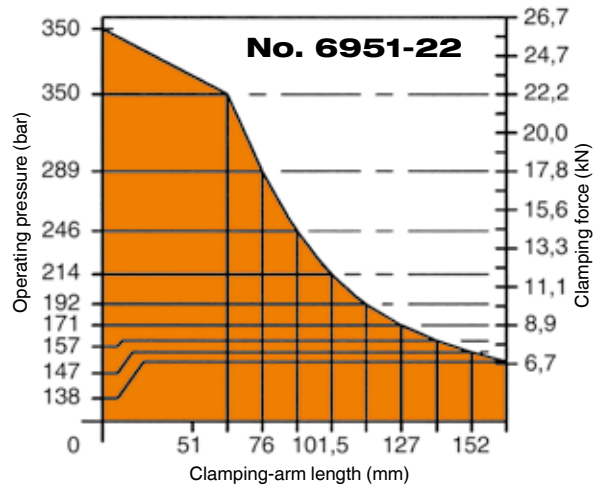
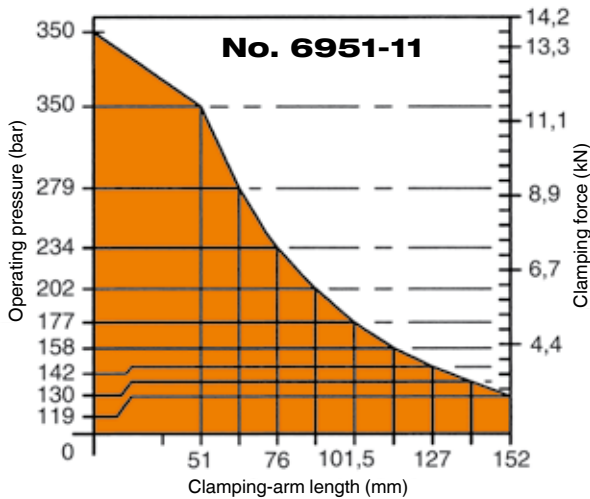
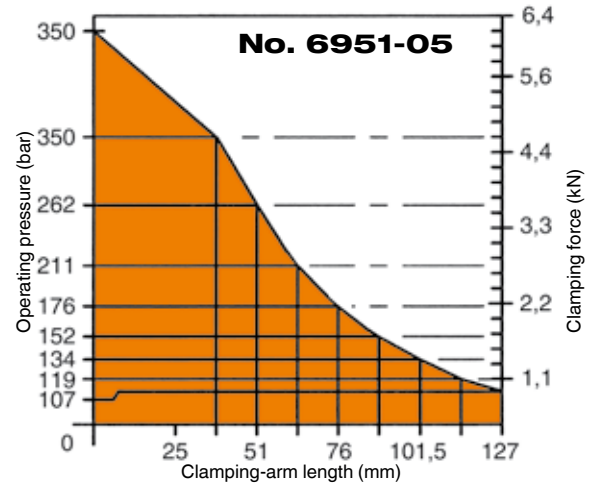
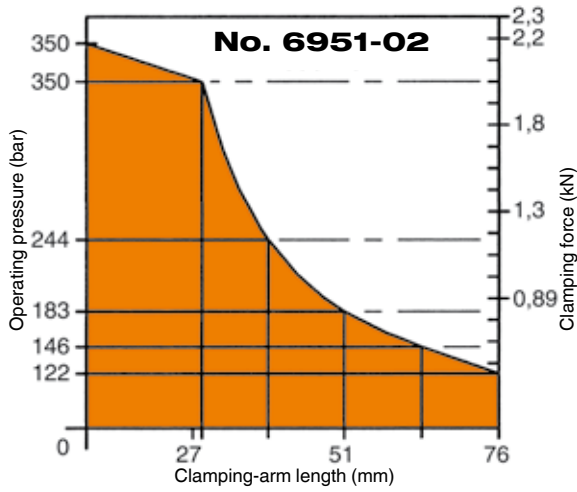

VERTICAL AND LINK CLAMPS FOR DEMANDING TASKS

VERTICAL CLAMPS

- > clamping force up to 20 kN
- > operating pressure 250 bar
- > chemically nitrided body

LINK CLAMPS

- > clamping force up to 33.8 kN
- > operating pressure 350 bar
- > chemically nitrided body

PRODUCT OVERVIEW:

Type	Clamping force [kN]	No. of models	Operating mode
6958Sx	7,0	1	single-acting
6958Ax	5,0 - 20,0	4	single-acting
6959Dx	5,0 - 12,2	3	double-acting
6959C	1,7 - 8,0	4	double-acting
6959KL	5,4 - 33,8	5	double-acting

PRODUCT EXAMPLES:

NO. 6958



- > Clamping force: 5 - 20 kN
- > connection type: drilled oil channels

NO. 6959C



- > Clamping force: 2 - 8 kN
- > connection type: O-ring or threaded port

NO. 6959KL



- > Clamping force: 5 - 34 kN
- > connection type: O-ring or threaded port

No. 6958Sx-16

Vertical Clamp

single acting,
max. operating pressure 350 bar,
min. operating pressure 40 bar.

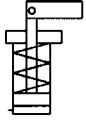

No. 6958SU-16



No. 6958ST-16

Mounting hole

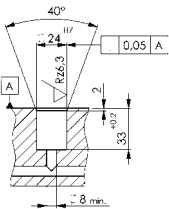
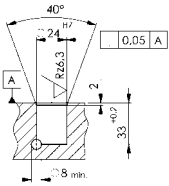

Order no.	Article no.	Piston force at 100 bar [kN]	Piston force at 350 bar [kN]	Vol. [cm ³]	Piston dia. [mm]	effective piston area [cm ²]	Weight [g]
322248	6958SU-16	2,0	7,0	1,9	16	2	280
322255	6958ST-16	2,0	7,0	1,9	16	2	290

Design:

Cylinder body made of steel, blued. Piston rod nitrided. Wiper at piston rod. Built-in return spring. Scope of supply includes clamp arm pin, but clamp arm not included.

Application:

This vertical clamp can be used for clamping in cavities or in very tight spaces.

Features:

Small dimensions, can be installed closely spaced side-by-side. The clamp arms can be exchanged easily. Oil supply by manifold.

Note:

Fastening screws according to ISO4762 M6, strength class 12.9, not included. Tightening torque $M_d = 18 \text{ Nm}$.

Does not fit surface-mounted block 6958AU-16-10-01, 6958AU-16-15-01, 6958AT-16-10-01 and 6958AT-16-15-01!

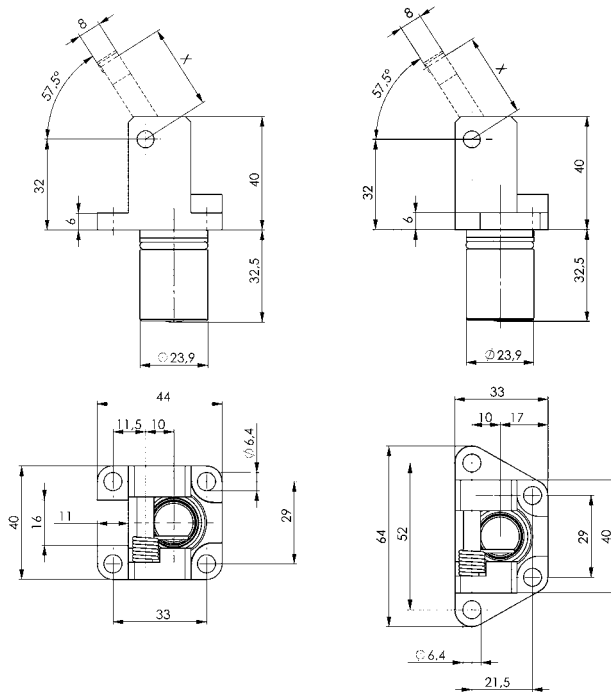

No. 6958S-16

Clamp arm out of steel

for vertical clamp no. 6958SSx-16

Order no.	Article no.	X	X1*	Clamping force at 100 bar [kN]	Clamping force at 250 bar [kN]	Clamping force at 350 bar [kN]	Weight [g]
320218	6958S-16-00-01	12	12	2,0	5,0	7,0	52
320234	6958S-16-00-02	18	12	1,3	3,3	4,6	60
320259	6958S-16-00-03	24	12	1,0	2,5	3,5	66
320275	6958S-16-00-04	30	12	0,8	2,0	2,8	72
322438	6958S-16-00-05**	-	12	-	-	-	74

Clamp arm made of case-hardened steel
**Clamp arm blank, unhardened

No. 6958A-16

Clamp arm out of aluminium

for vertical clamp no. 6958SSx-16

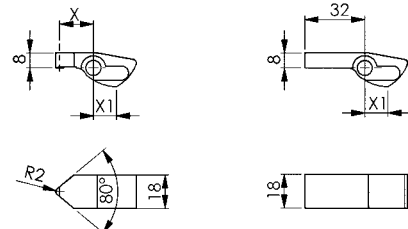

Order no.	Article no.	X	X1*	Clamping force at 100 bar [kN]	Clamping force at 250 bar [kN]	Weight [g]
320242	6958A-16-00-02	18	12	1,3	3,3	21
320267	6958A-16-00-03	24	12	1,0	2,5	23
320283	6958A-16-00-04	30	12	0,8	2,0	25
322453	6958A-16-00-05**	-	12	-	-	26

* X1 = level length at 90°
** Clamp arm blank



No. 6958Ax-16

Vertical Clamp

single acting,
max. operating pressure 250 bar,
min. operating pressure 40 bar.

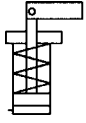

No. 6958AU-16

No. 6958AT-16

Mounting hole

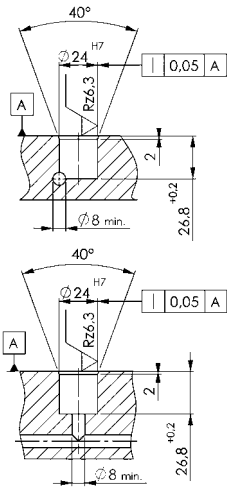

Order no.	Article no.	Piston force at 100 bar [kN]	Piston force at 250 bar [kN]	Vol. [cm ³]	Piston dia. [mm]	effective piston area [cm ²]	Weight [g]
322404	6958AU-16	2	5	1,9	16	2	220
322420	6958AT-16	2	5	1,9	16	2	237

Design:

Cylinder body made of steel, chemically nickel-plated. Piston rod nitrided. Wiper at piston rod. Built-in return spring. Scope of supply includes clamp arm pin, but clamp arm not included.

Application:

This vertical clamp can be used for clamping in cavities or in very tight spaces.

Features:

Small dimensions, can be installed closely spaced side-by-side. The clamp arms can be exchanged easily. Oil supply by manifold.

Note:

Fastening screws according to ISO4762 M6, strength class 12.9, not included. Tightening torque $M_d = 18 \text{ Nm}$.

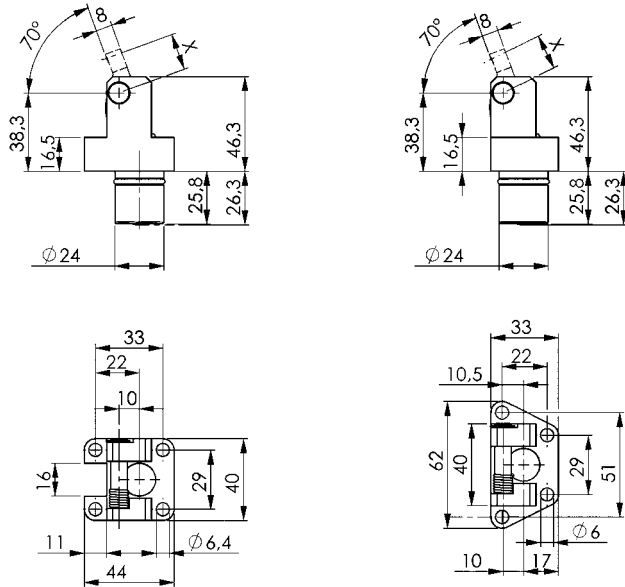

No. 6958S-16

Clamp arm out of steel

for vertical clamp no. 6958Ax-16

Order no.	Article no.	X	X1*	Clamping force at 100 bar [kN]	Clamping force at 250 bar [kN]	Weight [g]
324186	6958S-16-01-02	18	12	1,3	3,3	60
324178	6958S-16-01-03	24	12	1,0	2,5	66
324194	6958S-16-01-04	30	12	0,8	2,0	72
324418	6958S-16-01-05**	-	12	-	-	74

Clamp arm made of case-hardened steel

**Clamp arm blank, unhardened

No. 6958A-16

Clamp arm out of aluminium

for vertical clamp no. 6958Ax-16

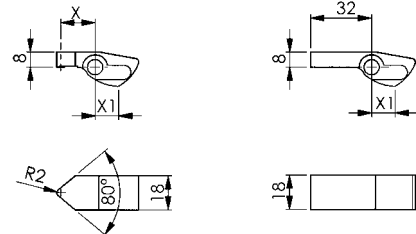

Order no.	Article no.	X	X1*	Clamping force at 100 bar [kN]	Weight [g]
324434	6958A-16-01-02	18	12	1,3	21
324459	6958A-16-01-03	24	12	1,0	23
324475	6958A-16-01-04	30	12	0,8	25
324483	6958A-16-01-05	-	12	-	26

* X1 = level length at 90°

** Clamp arm blank

No. 6958Ax-20

Vertical Clamp

single acting,
max. operating pressure 250 bar,
min. operating pressure 40 bar.

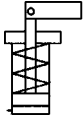

No. 6958AU-20



No. 6958AT-20

Mounting hole

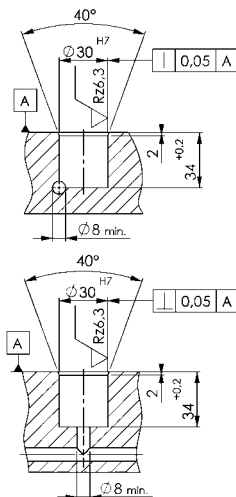

Order no.	Article no.	Piston force at 100 bar [kN]	Piston force at 250 bar [kN]	Vol. [cm ³]	Piston dia. [mm]	effective piston area [cm ²]	Weight [g]
322446	6958AU-20	3	8	4,0	20	3,1	357
322461	6958AT-20	3	8	4,0	20	3,1	392

Design:

Cylinder body made of steel, chemically nickel-plated. Piston rod nitrided. Wiper at piston rod. Built-in return spring. Scope of supply includes clamp arm pin, but clamp arm not included.

Application:

This vertical clamp can be used for clamping in cavities or in very tight spaces.

Features:

Small dimensions, can be installed closely spaced side-by-side. The clamp arms can be exchanged easily. Oil supply by manifold.

Note:

Fastening screws according to ISO4762 M8, strength class 12.9, not included. Tightening torque Md = 43 Nm.

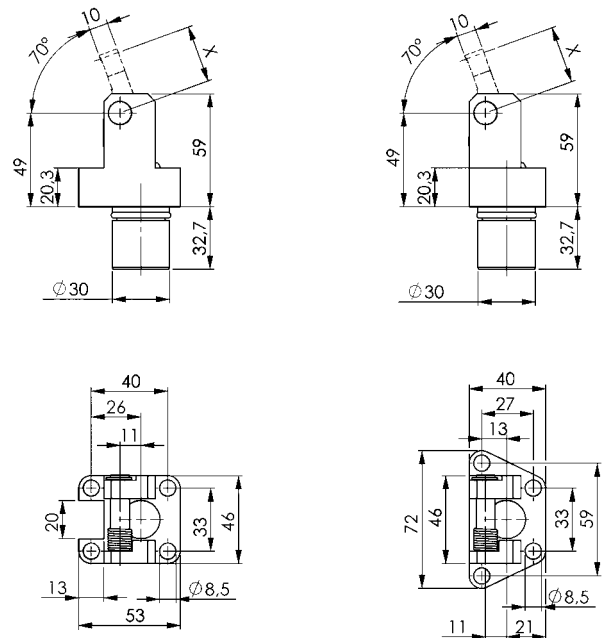

No. 6958S-20

Clamp arm out of steel

for vertical clamp no. 6958Ax-20

Order no.	Article no.	X	X1*	Clamping force at 100 bar [kN]	Clamping force at 250 bar [kN]	Weight [g]
322495	6958S-20-00-02	18	12	2,0	5,2	114
322511	6958S-20-00-03	24	12	1,5	3,9	125
322537	6958S-20-00-04	30	12	1,2	3,1	135
322552	6958S-20-00-05**	-	12	-	-	141

Clamp arm made of case-hardened steel

**Clamp arm blank, unhardened

No. 6958A-20

Clamp arm out of aluminium

for vertical clamp no. 6958Ax-20

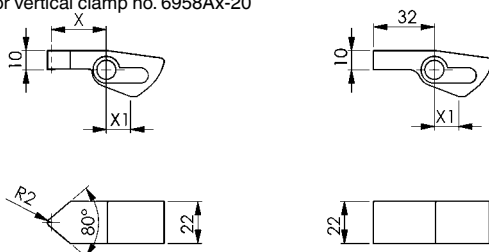

Order no.	Article no.	X	X1*	Clamping force at 100 bar [kN]	Weight [g]
322594	6958A-20-00-02	18	12	2,0	40
322610	6958A-20-00-03	24	12	1,5	43
322636	6958A-20-00-04	30	12	1,2	47
322651	6958A-20-00-05**	-	12	-	49

* X1 = level length at 90°

** Clamp arm blank

No. 6958Ax-25

Vertical Clamp

single acting,
max. operating pressure 250 bar,
min. operating pressure 40 bar.

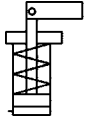

No. 6958AU-25



No. 6958AT-25

Mounting hole

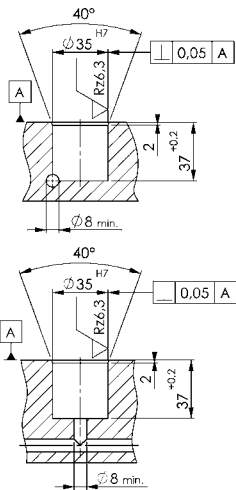

Order no.	Article no.	Piston force at 100 bar [kN]	Piston force at 250 bar [kN]	Vol. [cm³]	Piston dia. [mm]	effective piston area [cm²]	Weight [g]
322487	6958AU-25	4	12	6,7	25	4,9	576
322503	6958AT-25	4	12	6,7	25	4,9	640

Design:

Cylinder body made of steel, chemically nickel-plated. Piston rod nitrided. Wiper at piston rod. Built-in return spring. Scope of supply includes clamp arm pin, but clamp arm not included.

Application:

This vertical clamp can be used for clamping in cavities or in very tight spaces.

Features:

Small dimensions, can be installed closely spaced side-by-side. The clamp arms can be exchanged easily. Oil supply by manifold.

Note:

Fastening screws according to ISO4762 M10, strength class 12.9, not included. Tightening torque $M_d = 84 \text{ Nm}$.

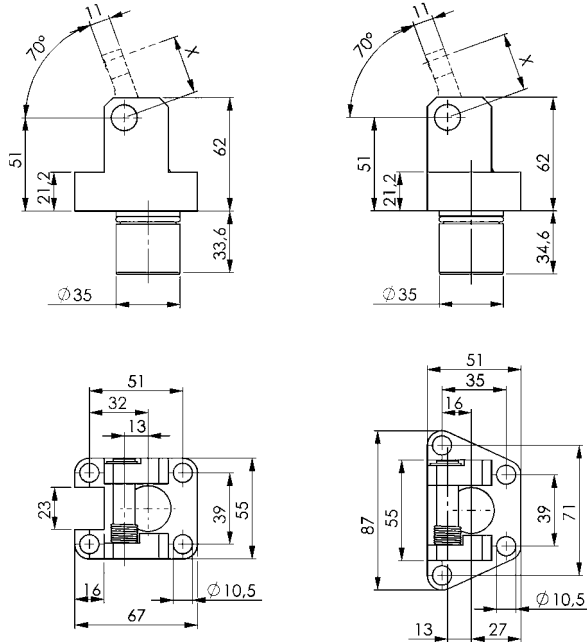

No. 6958S-25

Clamp arm out of steel

for vertical clamp no. 6958Ax-25

Order no.	Article no.	X	X1*	Clamping force at 100 bar [kN]	Clamping force at 250 bar [kN]	Weight [g]
322693	6958S-25-00-02	24	16	2,6	8,2	171
322719	6958S-25-00-03	32	16	2,0	6,1	191
322735	6958S-25-00-04	40	16	1,6	4,9	211
322750	6958S-25-00-05**	-	16	-	-	217

Clamp arm made of case-hardened steel

**Clamp arm blank, unhardened

No. 6958A-25

Clamp arm out of aluminium

for vertical clamp no. 6958Ax-25

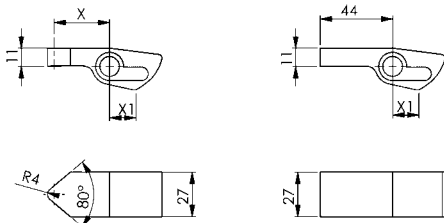

Order no.	Article no.	X	X1*	Clamping force at 100 bar [kN]	Weight [g]
322792	6958A-25-00-02	24	16	2,6	59
322818	6958A-25-00-03	32	16	2,0	66
322834	6958A-25-00-04	40	16	1,6	73
322859	6958A-25-00-05**	-	16	-	75

* X1 = level length at 90°

** Clamp arm blank

No. 6958Ax-32

Vertical Clamp

single acting,
max. operating pressure 250 bar,
min. operating pressure 40 bar.

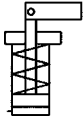

No. 6958AU-32



No. 6958AT-32

Mounting hole

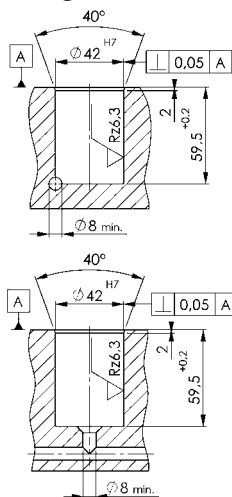

Order no.	Article no.	Piston force at 100 bar [kN]	Piston force at 250 bar [kN]	Vol. [cm ³]	Piston dia. [mm]	effective piston area [cm ²]	Weight [g]
322529	6958AU-32	8	20	14,4	32	8	926
322545	6958AT-32	8	20	14,4	32	8	1014

Design:

Cylinder body made of steel, chemically nickel-plated. Piston rod nitrided. Wiper at piston rod. Built-in return spring. Scope of supply includes clamp arm pin, but clamp arm not included.

Application:

This vertical clamp can be used for clamping in cavities or in very tight spaces.

Features:

Small dimensions, can be installed closely spaced side-by-side. The clamp arms can be exchanged easily. Oil supply by manifold.

Note:

Fastening screws according to ISO4762 M12, strength class 12.9, not included. Tightening torque $M_d = 145 \text{ Nm}$.

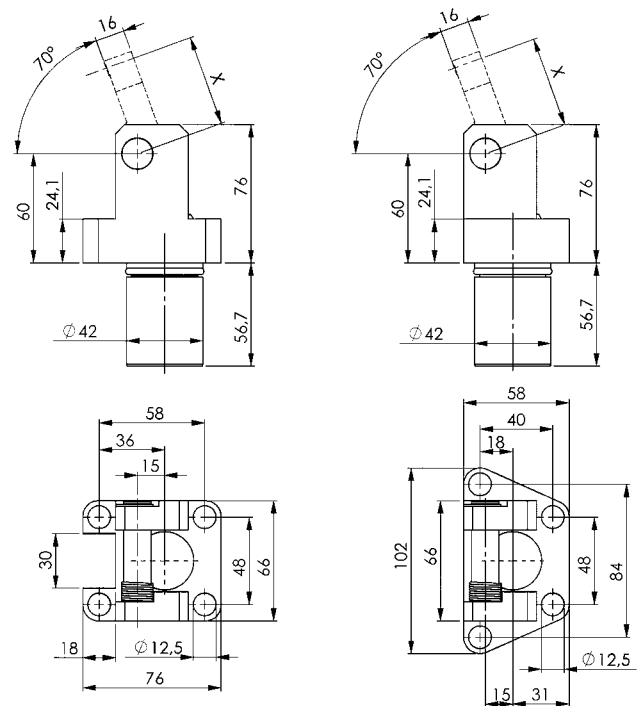

No. 6958S-32

Clamp arm out of steel

for vertical clamp no. 6958Ax-32

Order no.	Article no.	X	X1*	Clamping force at 100 bar [kN]	Clamping force at 250 bar [kN]	Weight [g]
322891	6958S-32-00-02	30	20	5,3	13,3	375
322917	6958S-32-00-03	40	20	4,0	10,0	417
322933	6958S-32-00-04	50	20	3,2	8,0	457
322958	6958S-32-00-05**	-	20	-	-	476

Clamp arm made of case-hardened steel
**Clamp arm blank, unhardened

No. 6958A-32

Clamp arm out of aluminium

for vertical clamp no. 6958Ax-32

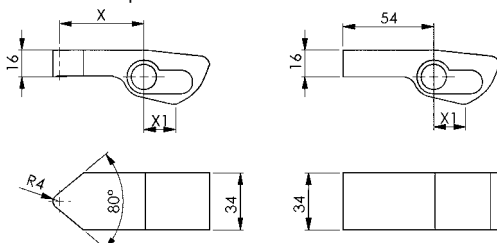

Order no.	Article no.	X	X1*	Clamping force at 100 bar [kN]	Weight [g]
322990	6958A-32-00-02	30	20	5,3	130
323014	6958A-32-00-03	40	20	4,0	144
323030	6958A-32-00-04	50	20	3,2	158
323055	6958A-32-00-05**	-	20	-	165

* X1 = level length at 90°
** Clamp arm blank

No. 6958AU

Surface-mounted block

with O-ring connection and threaded connection



Order no.	Article no.	A	A1	B	B1	C	C1	dia. D1	L	Weight [g]
322560	6958AU-16-10-01	40	29	44	33	17,0	11,5	6,5	50	261
322586	6958AU-20-10-01	46	33	53	40	20,5	14,0	8,5	57	418
322602	6958AU-25-10-01	55	39	67	51	27,0	19,0	10,5	60	693
322628	6958AU-32-10-01	66	48	76	58	31,0	22,0	12,5	82	1200

Design:

Made of aluminium, red anodised.

Supply scope includes O-ring Ø9x2, threaded plugs and fastening screws.

Application:

The surface-mounted block with O-ring connection from below and threaded connection can be flanged into the fixture as an adapter over the control channel without restriction for the cylindrical part of the vertical clamp or where the control oil supply to the vertical clamp has to be routed via external lines.

Note:

The flange surface on the fixture must be even, and must have a surface finish of Rz 6.3 in the area of the O-ring sealing surface. Other lengths are available on request.

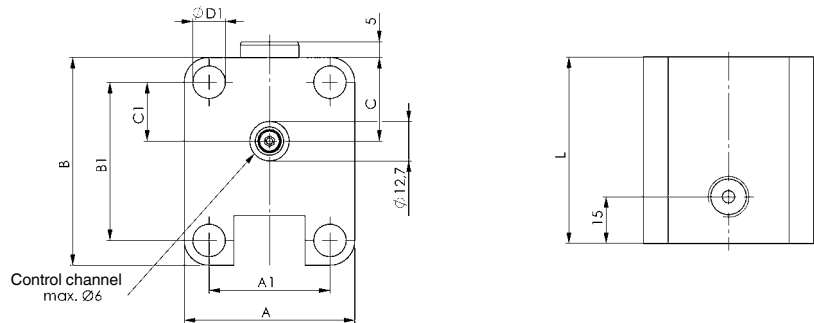

No. 6958AT

Surface-mounted block

with O-ring connection and threaded connection



Order no.	Article no.	A	A1	A2	B	B1	C	C1	dia. D1	L	Weight [g]
323089	6958AT-16-10-01	62	29	51	33	22	17,0	11,5	6,5	50	278
323105	6958AT-20-10-01	72	33	59	40	27	20,5	14,0	8,5	57	452
323121	6958AT-25-10-01	87	39	71	51	35	27,0	19,0	10,5	60	751
323147	6958AT-32-10-01	102	48	84	58	40	31,0	22,0	12,5	82	1302

Design:

Made of aluminium, red anodised.

Supply scope includes O-ring Ø9x2, threaded plugs and fastening screws.

Application:

The surface-mounted block with O-ring connection from below and threaded connection can be flanged into the fixture as an adapter over the control channel without restriction for the cylindrical part of the vertical clamp or where the control oil supply to the vertical clamp has to be routed via external lines.

Note:

The flange surface on the fixture must be even, and must have a surface finish of Rz 6.3 in the area of the O-ring sealing surface. Other lengths are available on request.

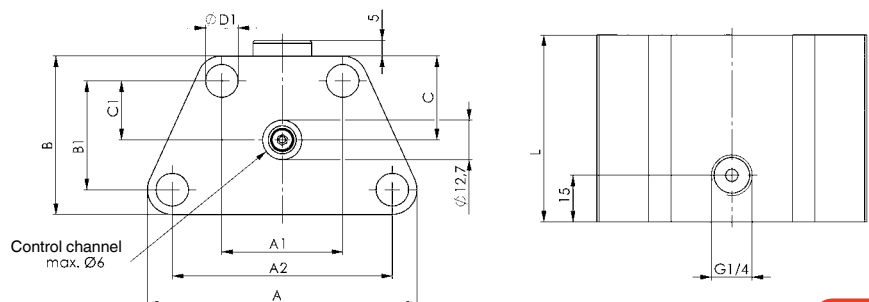

Subject to technical alterations.

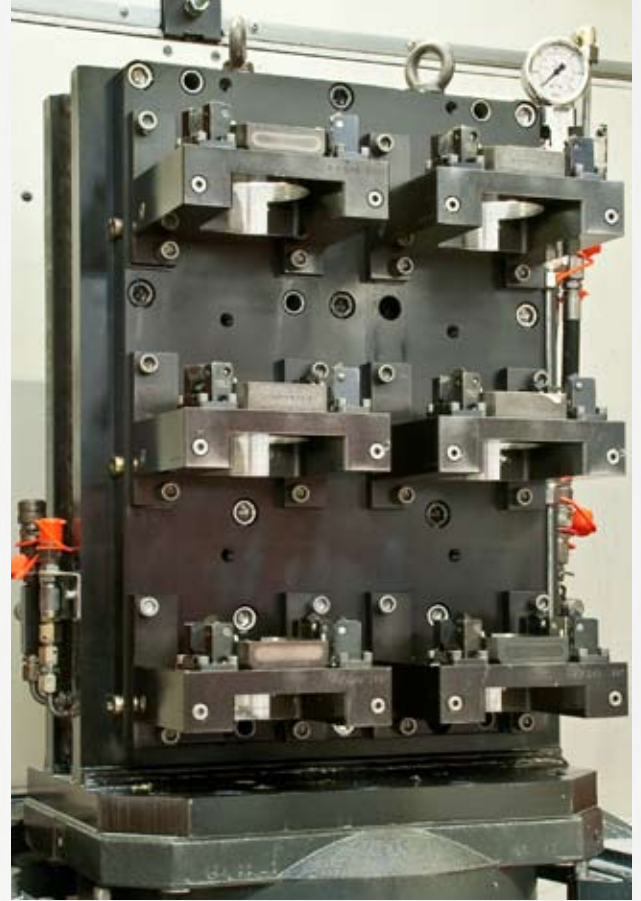

No. 6958 Vertical Clamp

Double-acting,
max. working pressure 250 bar,
min. operating pressure 25 bar.

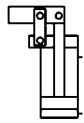

Order no.	Article no.	Clamping force F1 at 100 bar [kN]	Clamping force F1 at 250 bar [kN]	Piston force F5 at 100 bar [kN]	Piston force F5 at 250 bar [kN]	Oil capacity clamp [cm ³]	Oil capacity unclamp [cm ³]	effective piston area clamp [cm ²]	effective piston area unclamp [cm ²]	Md [Nm]	Weight [g]
326272	6958DU-16	1,3	3,3	2,0	5,0	2,0	1,2	2,0	1,2	16	334
326314	6958DU-20	2,1	5,2	3,1	7,8	3,8	2,4	3,1	2,0	33	624
326371	6958DU-25	3,2	8,2	4,9	12,2	6,9	4,1	4,9	2,9	65	906

Design:

Hydraulic cylinder as a drop-in cartridge. Top mounting with four cylinder screws (resistance min. 10.9). All components from hardened, tempered and burnished steel. Piston and hinge pins from hardened, tempered and nitrided steel. Metal wiper to protect the dirt wiper integrated into the housing. Compressed air nozzle for pneumatic clamping control made of highly rigid plastic. Supply scope includes hinge pins, tension plates and compressed air nozzle, but not clamping arm.

Application:

The double-acting vertical clamp is highly suited to clamping in clamping pockets. For clearly defined return movements.

Features:

Small dimensions. Allows close side-by-side positioning. Clamping arm easy to change with built-in vertical clamp. The horizontal central axis on the standard lever and the pressure point on the workpiece lie on one plane. This prevents relative movement on the workpiece.

Oil is supplied via cross-bored channels in the fixture. To protect the O-rings sitting radially on the clamp, the cross channels at the installation hole must be rotated freely and equipped with insertion lead-ins. The double acting Vertical Clamp is supplied with an integrated air sensing function. See function diagram below.

With an air supply connected to the sensing port a free flow exists when the clamp is in the open (unclamped) position.

When the clamp is in the closed (clamped) position the air supply is blocked resulting in a back pressure.

A suitable pressure switch or flow switch (customer supply) can be used to monitor this condition.

Note:

The signal converter is not included in the supply scope.

Formula for determining the clamping force F1:

Clamping force = F1 (kN), Piston force = F5 (kN), Operating lever = B (mm), Load lever = C (mm)

$$F1 = F5 \times B / C$$

The lever ratio B to C is 1 to 1.5 for the standard levers!

In preparing the blank levers, deviations that cause a higher clamping force are permitted only in exceptional cases.

Dynamic pressure monitoring :

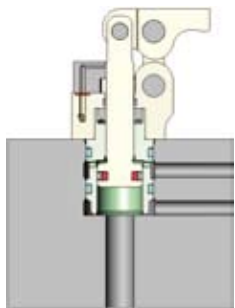

closed: clamped

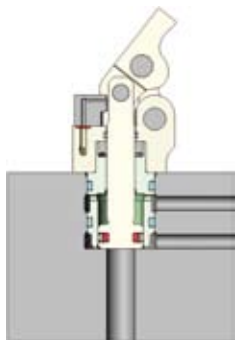

open: unclamped

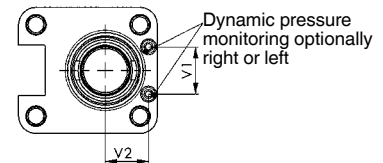
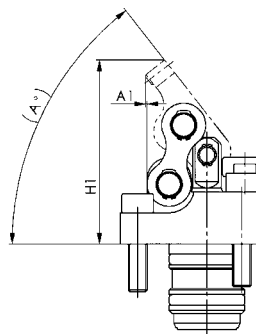

Dynamic pressure monitoring optionally right or left

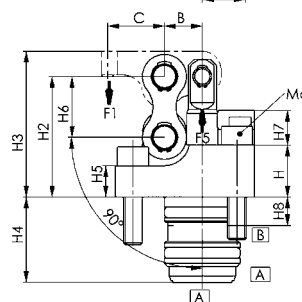

[A] = clamp
[B] = unclamp

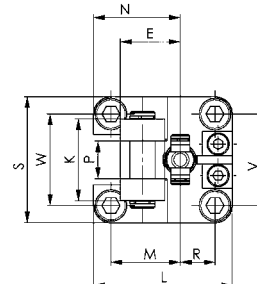

Dimensions

Order no.	Article no.	A	A1	B	C	E	H	H1	H2	H3	H4	H5	H6	H7	H8	K	L	M	N	P	R	S	V	V1	V2	W
326272	6958DU-16	51,9	0,40	12	18,0	19,0	16,5	58,4	38,3	46,3	27	10	19,3	11	9	26	44	22,0	27,5	12	11	40,0	29	15	13,7	29
326314	6958DU-20	54,0	1,25	14	21,0	23,0	20,3	73,2	49,0	59,0	34	10	25,0	16	12	32	53	26,0	32,5	16	14	46,0	33	15	17,5	33
326371	6958DU-25	51,2	0,70	17	25,5	27,5	21,0	79,4	51,0	62,0	37	10	27,0	16	22	39	67	32,0	40,0	20	19	55,0	39	15	21,0	39

Subject to technical alterations.

No. 6958

Vertical Clamp

Double-acting,
max. working pressure 250 bar,
min. operating pressure 25 bar.

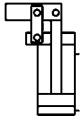

Order no.	Article no.	Clamping force F1 at 100 bar [kN]	Clamping force F1 at 250 bar [kN]	Piston force F5 at 100 bar [kN]	Piston force F5 at 250 bar [kN]	Oil capacity clamp [cm³]	Oil capacity unclamp [cm³]	effective piston area clamp [cm²]	effective piston area unclamp [cm²]	Md [Nm]	Weight [g]
326231	6958DT-16	1,3	3,3	2,0	5,0	2,0	1,2	2,0	1,2	16	365
326298	6958DT-20	2,1	5,2	3,1	7,8	3,8	2,4	3,1	2,0	33	386
326397	6958DT-25	3,2	8,2	4,9	12,2	6,9	4,1	4,9	2,9	65	1015

Design:

Hydraulic cylinder as a drop-in cartridge. Top mounting with four cylinder screws (resistance min. 10.9). All components from hardened, tempered and burnished steel. Piston and hinge pins from hardened, tempered and nitrided steel. Metal wiper to protect the dirt wiper integrated into the housing. Compressed air nozzle for pneumatic clamping control made of highly rigid plastic. Supply scope includes hinge pins, tension plates and compressed air nozzle, but not clamping arm.

Application:

The double-acting vertical clamp is highly suited to clamping in clamping pockets. For clearly defined return movements.

Features:

Small dimensions. Allows close side-by-side positioning. Clamping arm easy to change with built-in vertical clamp. The horizontal central axis on the standard lever and the pressure point on the workpiece lie on one plane. This prevents relative movement on the workpiece. Oil is supplied via cross-bored channels in the fixture. To protect the O-rings sitting radially on the clamp, the cross channels at the installation hole must be rotated freely and equipped with insertion lead-ins. The double acting Vertical Clamp is supplied with an integrated air sensing function. See function diagram below. With an air supply connected to the sensing port a free flow exists when the clamp is in the open (unclamped) position. When the clamp is in the closed (clamped) position the air supply is blocked resulting in a back pressure. A suitable pressure switch or flow switch (customer supply) can be used to monitor this condition.

Note:

The signal converter is not included in the supply scope.

Formula for determining the clamping force F1:
Clamping force = F1 (kN), Piston force = F5 (kN), Operating lever = B (mm), Load lever = C (mm)

$$F1 = F5 \times B / C$$

The lever ratio B to C is 1 to 1.5 for the standard levers!

In preparing the blank levers, deviations that cause a higher clamping force are permitted only in exceptional cases.

Dynamic pressure monitoring :

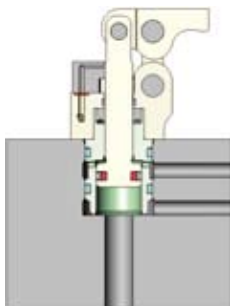

closed: clamped

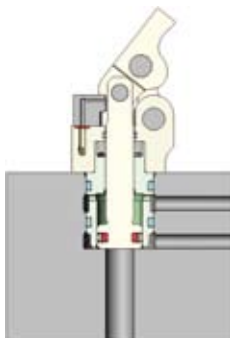

open: unclamped

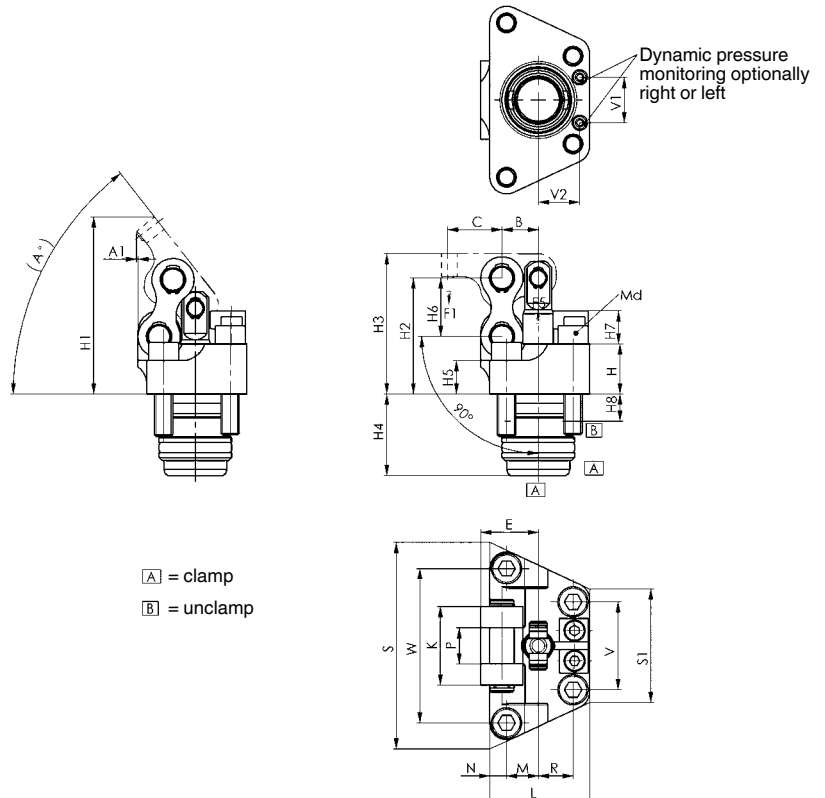

Dimensions

Order no.	Article no.	A	A1	B	C	E	H	H1	H2	H3	H4	H5	H6	H7	H8	K	L	M	N	P	R	S	S1	V	V1	V2	W
326231	6958DT-16	51,9	0,40	12	18,0	19,0	16,5	58,4	38,3	46,3	27	11	19,3	11	9	26	33	10,5	5,5	12	11,5	68,3	37,49	29	15	13,7	51
326298	6958DT-20	54,0	1,25	14	21,0	23,0	20,3	73,2	49,0	59,0	34	14	25,0	16	12	32	40	13,0	6,0	16	14,0	78,9	41,60	33	15	17,5	59
326397	6958DT-25	51,2	0,70	17	25,5	27,5	21,0	79,4	51,0	62,0	37	12	27,0	16	22	39	51	16,0	8,0	20	19,0	96,1	48,55	39	18	21,0	71

Subject to technical alterations.

Dimensions table for reception hole

Order no.	Article no.	dia. D H7	dia. F	G x T	H10	J	M	R	V	V1	V2	W	dia. X	X1	dia. Y	Y1
326272	6958DU-16	24	25,4	M6x15	27	2	22,0	11	29	15	13,7	29	5	11	5	24,5
326314	6958DU-20	30	31,4	M8x16	34	2	26,0	14	33	15	17,5	33	5	13	5	31,5
326371	6958DU-25	35	36,4	M10x20	37	2	32,0	19	39	15	21,0	39	5	14	5	34,5
326231	6958DT-16	24	25,4	M6x15	27	2	10,5	11,5	29	15	13,7	51	5	11	5	24,5
326298	6958DT-20	30	31,4	M8x16	34	2	13,0	14,0	33	15	17,5	59	5	13	5	31,5
326397	6958DT-25	35	36,4	M10x20	37	2	16,0	19,0	39	15	21,0	71	5	14	5	34,5

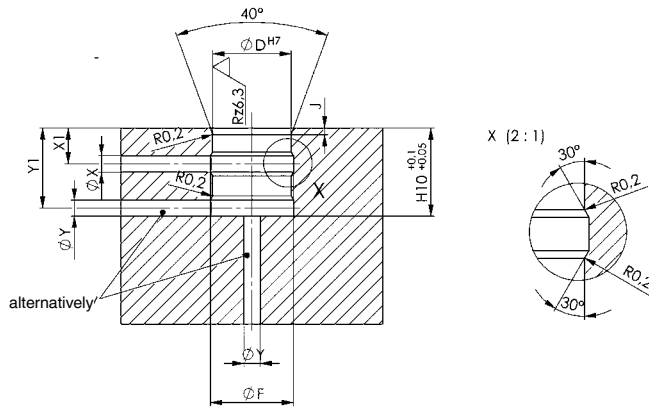

No. 6958DU

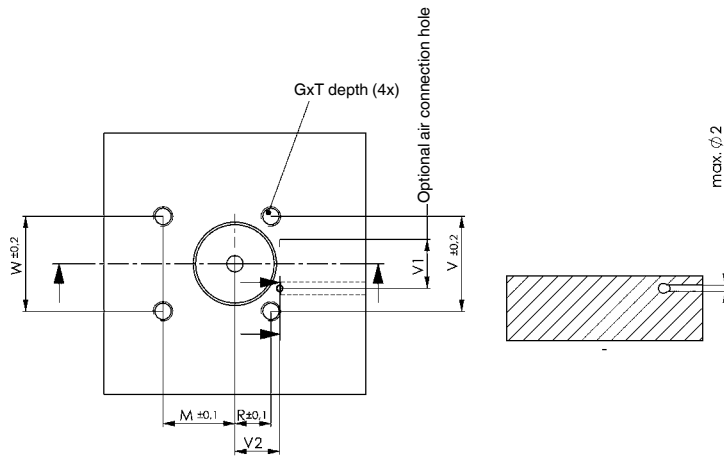

No. 6958DT

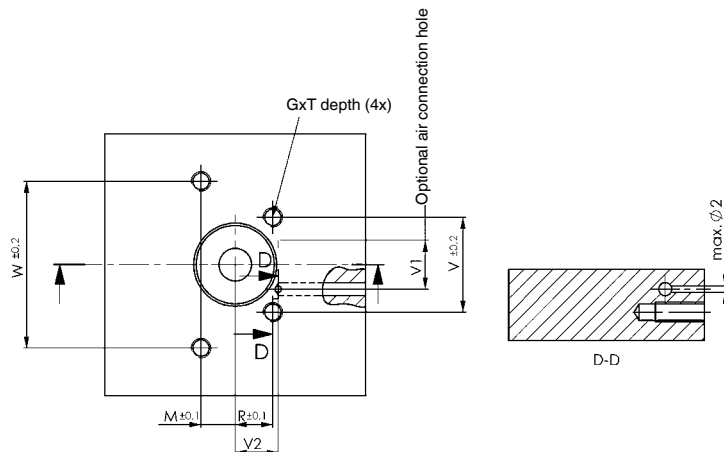

No. 6958D-xx-04

Clamp arm out of steel

Tempering steel,
for link clamp no. 6958DU
and no. 6958DT.

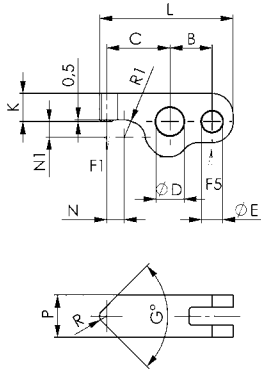

Order no.	Article no.	B	C	dia. D	dia. E	G	K	L	N	N1	P	R	R1	Clamping force F1 at 100 bar [kN]	Clamping force F1 at 250 bar [kN]	Weight [g]
326215	6958D-16-04	12	18,0	8	6	90	8	38,0	5,0	4,5	12	2,0	5,0	1,3	3,3	31
326322	6958D-20-04	14	21,0	10	7	80	10	44,5	4,5	7,0	16	2,5	7,5	2,1	5,2	60
326413	6958D-25-04	17	25,5	12	9	80	11	53,5	7,0	7,0	20	3,0	7,5	2,6	8,2	94

Note:

Lever ratios must be respected.

No. 6958DR

Clamping arm, blank

Tempering steel,
for link clamp no. 6958DU and no. 6958DT.

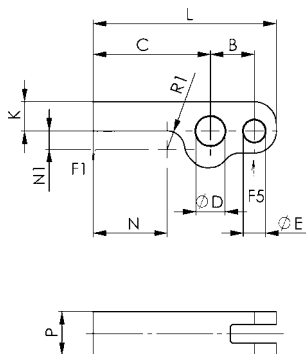

Order no.	Article no.	B	C	dia. D	dia. E	K	L	N	N1	P	R1	Weight [g]
326256	6958DR-16	12	32	8	6	8	50	20,0	5,0	12	5,0	42
326348	6958DR-20	14	40	10	7	10	61	23,5	7,5	16	7,5	86
326439	6958DR-25	17	50	12	9	11	75	31,5	7,5	20	7,5	140

Note:

Lever ratios must be respected.

Formula for determining the clamping force F1:

Clamping force (F1)
Piston force (F5)
Operating lever (B)
Load lever (C)

$$F1 = F5 \times B / C$$



No. 6959C Link clamp

double-acting
max. operating pressure 250 bar,
min. operating pressure 25 bar.

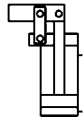

Order no.	Article no.	Clamping force F1 at 100 bar* [kN]	Clamping force F1 at 250 bar* [kN]	Piston force F5 at 100 bar [kN]	Piston force F5 at 250 bar [kN]	Oil capacity clamp [cm³]	Oil capacity unclamp [cm³]	effective piston area clamp [cm²]	effective piston area unclamp [cm²]	Md [Nm]	Weight [g]
325563	6959C-12	0,7	1,7	1,1	2,8	1,7	0,9	1,1	0,6	5	188
325019	6959C-16	1,2	3,1	2,0	5,0	3,2	1,4	2,0	0,9	10	350
324905	6959C-20	1,9	4,9	3,1	7,8	6,0	2,6	3,1	1,4	18	590
324657	6959C-25	3,2	8,0	4,9	12,2	10,3	3,7	4,9	1,8	43	1155

* Clamping force when using standard clamping lever

Design:

Hydraulic cylinder as a drop-in cartridge. Top mounting with four cylinder screws (resistance min. 10.9). All components from hardened, tempered and burnished steel. Piston rod and hinge pins from hardened, tempered and nitrided steel. Additional bronze wiper to protect the dirt wiper.

Supply scope includes hinge pins and tension plates, but not clamping arm.

Application:

The double-acting link clamp is highly suited to clamping in clamping pockets.

Features:

Small dimensions. Allows close side-by-side positioning. Clamping arm easy to change with link clamps mounted. The standard lever centre axis and the pressure point on the workpiece are always in one plane at (Z). This prevents relative movement on the workpiece. Oil is supplied via cross-bored channels in the fixture. The integrated cartridge is stepped. This prevents the radial O-rings from becoming damaged as they are installed in or removed from the cross channels.

Note:

Formula for determining the clamping force F1:

Clamping force F1 [kN] = piston force F5 [kN] x operating lever B / load lever C

With standard levers, the ratio of B to C is 1 to 1.5.

In preparing the blank lever, deviations that cause a higher clamping force F1 are permitted only in exceptional cases.

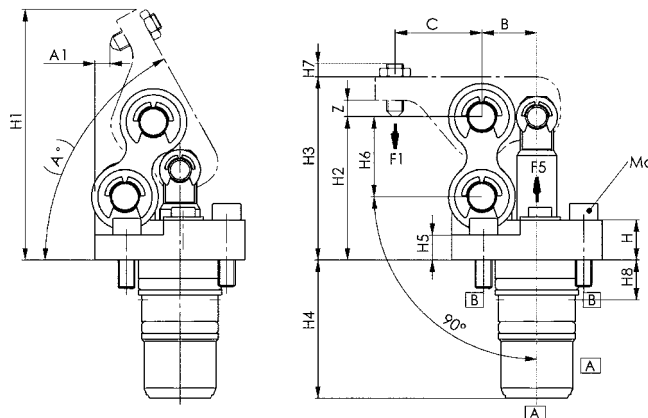

Z= optimum setting

[A] = clamp
[B] = unclamp

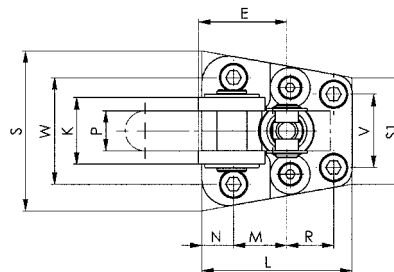

Dimensions

Order no.	Article no.	A	A1	B	C	E	H	H1	H2	H3	H4	H5	H6	H7	H8	K	L	M	N	P	R	S	S1	V	W	Z
325563	6959C-16	60,0°	3,0	13,5	22	21,0	10,0	58,9	33	41,5	34,0	5,5	18	3,5	11,5	16	37,5	15,0	6,0	10	12,0	42	28	18	29	4
325019	6959C-16	61,0°	5,6	16,5	26	26,5	12,0	75,2	43	55,0	41,5	7,5	24	4,0	12,0	20	45,0	16,0	9,5	12	14,0	48	32	22	32	4
324905	6959C-20	60,8°	5,5	19,5	31	30,5	14,5	84,8	47	60,0	50,0	9,0	26	7,0	16,5	27	51,5	21,0	9,5	15	16,0	56	38	28	42	5
324657	6959C-25	54,3°	1,0	24,0	37	37,5	16,0	106,4	61	76,0	52,5	11,5	34	5,0	17,0	34	65,0	30,5	7,0	20	20,5	72	46	34	54	5

Subject to technical alterations.

Mounting hole

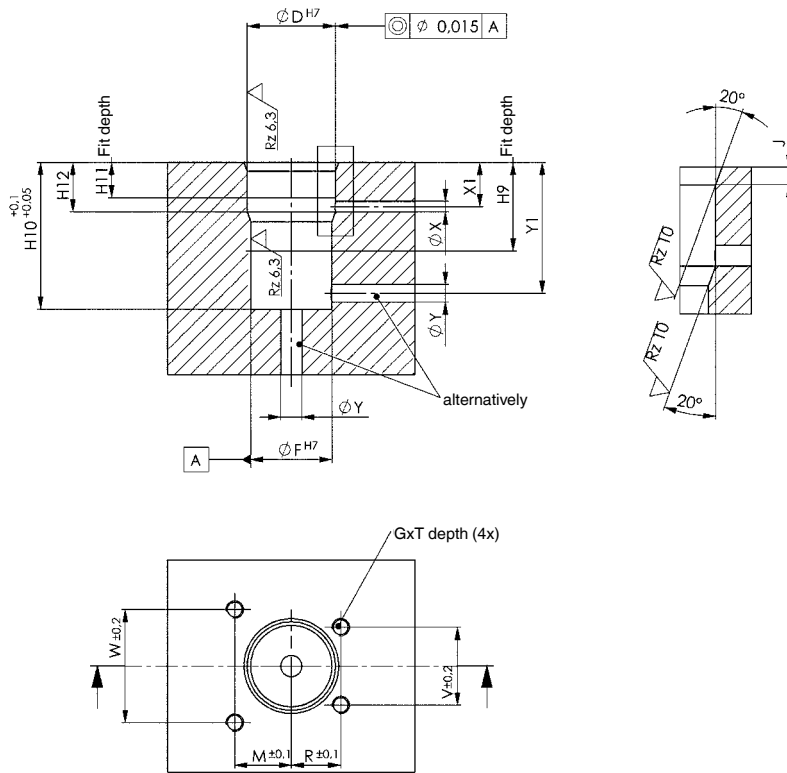

Dimensions table for reception hole

Order no.	Article no.	dia. D H7	dia. F H7	G x T	H9	H10	H11	H12	J	M	R	V	W	dia. X	X1	dia. Y	Y1
325563	6959C-12	20	17	M4x12	25	34,0	10	14	2,5	15,0	12,0	18	29	4	11,0-12	6	28-31
325019	6959C-16	25	23	M5x10	25	41,5	10	14	2,5	16,0	14,0	22	32	4	11,5-12	6	27-38
324905	6959C-20	30	28	M6x13	36	50,0	14	20	3,3	21,0	16,0	28	42	4	15,0-18	6	38-47
324657	6959C-25	38	35	M8x16	38	52,5	14	20	2,5	30,5	20,5	34	54	4	13,0-18	6	39-49



No. 6959C-xx-30

Clamping arm, standard

for link clamp no. 6959C



Order no.	Article no.	Clamping force F1 at 100 bar [kN]	Clamping force F1 at 350 bar [kN]	Weight [g]
325522	6959C-12-30	0,67	1,7	35
325225	6959C-16-30	1,2	3,1	70
325233	6959C-20-30	1,9	4,9	106
325464	6959C-25-30	3,1	7,9	222

Design:

Hardened, tempered and burnished steel. Supply scope includes pressure screw.

Note:

Lever ratios must be respected.

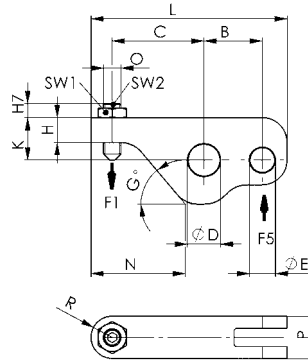

Dimensions

Order no.	Article no.	B	C	dia. D	dia. E	G	H	K	L	N	O	P	R	SW1	SW2
325522	6959C-12-30	13,5	22	7	5	50°	4,5	8,5	45,5	20,8	M4	10	5,0	7	2,0
325225	6959C-16-30	16,5	26	9	7	50°	7,0	12,0	55,5	26,7	M5	12	6,0	8	2,5
325233	6959C-20-30	19,5	31	10	8	50°	8,0	13,0	65,0	32,4	M6	15	7,5	10	3,0
325464	6959C-25-30	24,0	37	13	10	45°	10,0	15,0	80,0	37,0	M8	20	6,0	13	4,0

No. 6959CR-xx-04

Clamping arm, blank

for link clamp no. 6959C



Order no.	Article no.	B	C	dia. D	dia. E	G	K	L	N	P	Weight [g]
325548	6959CR-12-04	13,5	34,0	7	5	50°	8,5	53,0	30,5	10	41
325035	6959CR-16-04	16,5	42,5	9	7	50°	12,0	66,0	37,2	12	85
324996	6959CR-20-04	19,5	50,0	10	8	50°	13,0	77,5	45,0	15	134
325506	6959CR-25-04	24,0	63,5	13	10	45°	15,0	98,0	57,0	20	272

Design:

Hardened, tempered and burnished steel.

Note:

Lever ratios must be respected.

Formula for determining the clamping force F1:

Clamping force F1 [kN] = piston force F5 [kN] x operating lever B / load lever C

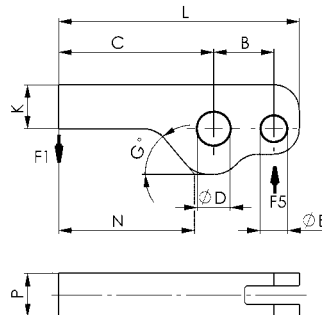

No. 6959C-xx-15-01

Surface-mounted block

with O-ring and threaded connection



Order no.	Article no.	Screws for each size	Weight [g]
325290	6959C-12-15-01	2x M4x70, 2x M4x65	505
324632	6959C-16-15-01	2x M5x75, 2x M5x70	750
324640	6959C-20-15-01	2x M6x85, 2x M6x80	1100
325480	6959C-25-15-01	2x M8x95, 2x M8x90	1685

Design:

Steel, burnished.

Supply scope includes O-ring Ø9x2, threaded plugs and fastening screws.

Application:

The surface-mounted block can be flange-mounted as an adapter via the control channels in the fixture. It can also be arranged on the fixture and used there when the control oil supply has to be routed to the link clamps via external lines.

Note:

The flange surface on the fixture must be even for using the O-ring connection and must have a surface finish of Rz 6.3 around the O-ring sealing surface. The flange surface on the fixture must be even for using the threaded connections.

Other lengths available on request.

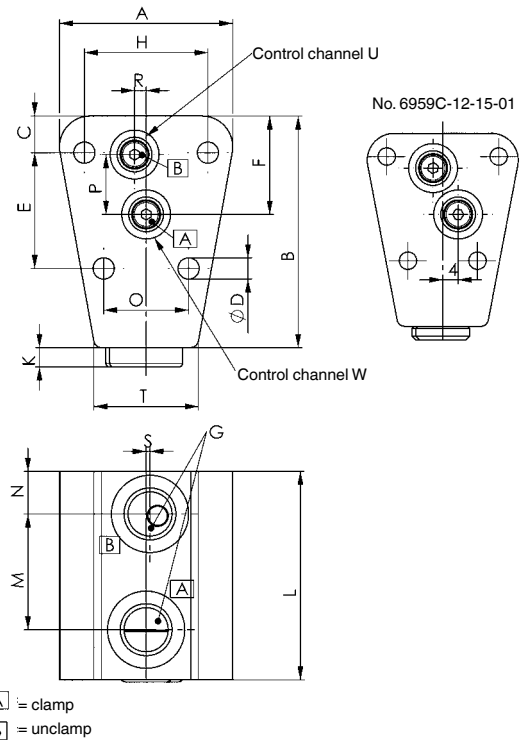

Dimensions

Order no.	Article no.	A	B	C	dia. D	E	F	G	H	K	L	M	N	O	P	R	S	dia. U	dia. W
325290	6959C-12-15-01	39,1	50,0	6,0	4,5	27	21,0	G1/8	29	4	50	25	11,5	18	12,0	2,5	1,0	6	6
324632	6959C-16-15-01	44,9	60,0	9,5	5,5	30	25,5	G1/4	32	5	54	30	11,0	22	15,5	3,0	1,0	6	6
324640	6959C-20-15-01	53,0	68,5	9,5	7,0	37	30,5	G1/4	42	5	60	30	13,0	28	20,0	5,0	0,0	6	6
325480	6959C-25-15-01	69,0	78,0	7,0	8,5	51	37,5	G1/4	54	5	65	31	15,0	34	27,0	8,0	5,0	6	6

No. 6959KL

Link Clamp

double-acting
max. operating pressure 350 bar,
min. operating pressure 25 bar.

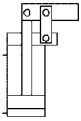

Order no.	Article no.	Clamping force at 100 bar [kN]	Clamping force at 350 bar* [kN]	Piston force at 100 bar [kN]	Piston force at 350 bar [kN]	Stroke [mm]	Oil capacity clamp [cm ³]	Oil capacity unclamp [cm ³]	effective piston area clamp [cm ²]	effective piston area unclamp [cm ²]	Md [Nm]	Weight [g]
321695	6959KL-160	1,5	5,4	2,0	7,0	17,0	7,4	1,5	2,0	0,9	8,3	755
322057	6959KL-200	2,4	8,4	3,1	11,0	23,0	7,2	3,2	3,1	1,4	14,0	1876
321711	6959KL-250	3,8	13,2	4,9	17,2	26,5	13,0	6,3	4,9	2,4	35,0	2390
322032	6959KL-320	6,2	21,6	8,0	28,1	34,0	27,3	10,7	8,0	3,1	69,0	5320
322040	6959KL-400	9,7	33,8	12,6	44,0	43,0	54,0	27,6	12,6	6,4	120,0	8820

* Clamping force when using standard clamping lever

Design:

Cylinder housing from hardened and tempered steel. Pistons and bolts from from hardened, tempered, ground and nitrided steel. All parts nickel plated.

Supply scope includes hinge pins and tension plates, but not clamping arm.

Application:

Link clamps are used in clamping fixtures in which workpieces must be freely accessible and loaded from above. Particularly suitable for clamping in clamping pockets.

Features:

Head-flange version, hydraulic pressure supply possible through threaded ports on the side and through oil channels on the flat face with O-ring seals. Lever mechanism can be turned in the range of 180° in 90° steps. Special versions are possible.

Note:

- Maximum speed of operation 0.5 m/s
- Minimum operating pressure 40 bar
- Proximity switch and electrical pressure-point monitoring can be supplied on request.
- piston force [kN] = piston surface area [cm²] x operating pressure [bar] / 100
- clamping force [kN] = piston surface area [cm²] x operating pressure [bar] * B [mm] / (C [mm] x 100)

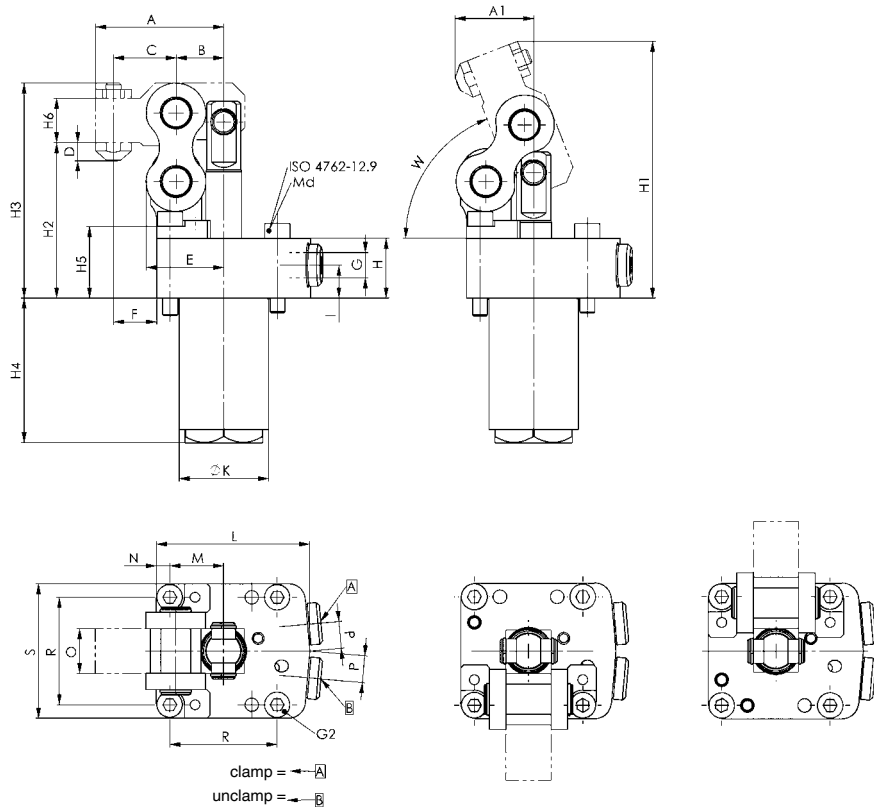

Dimensions

Order no.	Article no.	Piston rod dia. [mm]	Piston dia. [mm]	A	A1	B	C	D	E	F	G	G2	H	H1	H2	H3	H4	H5	H6	I	dia. K	L	M	N	O	P	R	S	W
321695	6959KL-160	12	16	43,0	26,3	16,0	21,0	6,0	26,0	14,5	G1/8	M 5	20	86,0	52	72	49	24	15	11,0	30	51,5	18	4,5	15	9	36	45	68,6°
322057	6959KL-200	15	20	56,5	33,0	21,0	27,5	6,0	35,0	13,5	G1/4	M 6	26	120,5	72	103	60	34	25	14,0	38	70,0	27	8,0	20	14	54	70	74,4°
321711	6959KL-250	18	25	63,5	40,3	24,0	31,5	8,0	40,0	18,5	G1/4	M 8	27	129,3	75	110	65	37	27	14,0	42	74,0	30	7,0	24	14	60	74	73,7°
322032	6959KL-320	25	32	82,0	51,0	32,0	42,0	8,0	52,0	24,0	G1/4	M10	35	167,5	103	145	83	47	27	15,0	52	100,0	39	11,0	30	14	78	100	70,5°
322040	6959KL-400	28	40	101,0	61,5	39,5	51,5	8,0	65,5	28,5	G1/4	M12	35	193,0	113	169	96	50	27	17,5	63	125,0	50	12,5	35	18	100	125	72,2°

Subject to technical alterations.

Dimensions table for flange plate

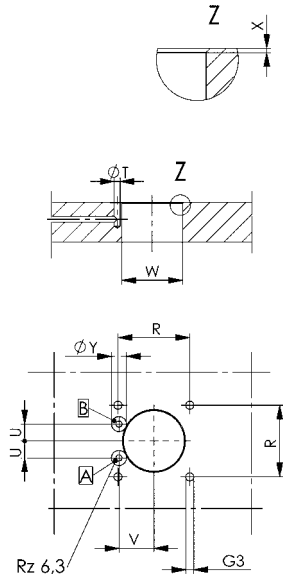

Order no.	Article no.	G3 x depth	R ±0,2	dia. T	U	V	dia. W	X	dia. Y x max. depth
321695	6959KL-160	M5 x 11	36	3,0	8,5	17,5	30,5	0,5 x 45°	8 x 0,1
322057	6959KL-200	M6 x 18	54	5,0	15	21,5	38,5	0,5 x 45°	13 x 0,1
321711	6959KL-250	M8 x 16	60	5,0	16,0	23,5	42,5	0,5 x 45°	13 x 0,1
322032	6959KL-320	M10x16	78	5,0	16,0	30,0	52,5	0,5 x 45°	13 x 0,1
322040	6959KL-400	M12x18	100	5,6	18,0	38,0	63,5	0,5 x 45°	13 x 0,1



O-ring

(included in scope of supply)

Order no.	O-ring	For link clamps	Weight [g]
409508	5 x 1,5 - PU 93 Shore A	6959KL-160	1
321646	9 x 2,0 - PU 93 Shore A	6959KL-200, -250, -320, -400	1

No. 6959-**-10

Sensor sub-assembly

for link clamp no. 6959KL

Order no.	Article no.	For link clamps	Weight [g]
320622	6959-01-10	6959KL-160	250
320630	6959-05-10	6959KL-200, -250, -320, -400	250



Order no. 320622

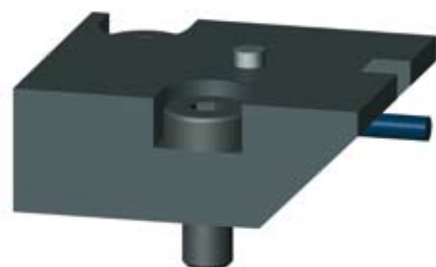

Order no. 320630

No. 6959KL-xx-30

Clamping arm, standard



Order no.	Article no.	Clamping force F1 at 100 bar [kN]	Clamping force F1 at 350 bar [kN]	Weight [g]
325241	6959KL-16-30	1,5	5,4	65
325266	6959KL-20-30	2,4	8,4	203
325282	6959KL-25-30	3,8	13,2	286
325308	6959KL-32-30	6,2	21,6	522
325324	6959KL-40-30	9,7	33,8	867

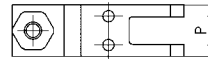
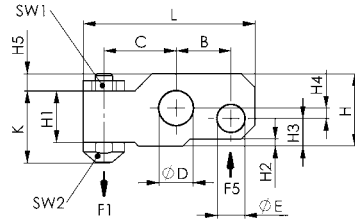

Dimensions

Order no.	Article no.	B	C	dia. D	dia. E	H	H1	H2	H3	H4	H5	K	L	P	SW1	SW2
325241	6959KL-16-30	16,0	21,0	10	8	21	15	2	8	3	5	21	50	15	11	11
325266	6959KL-20-30	21,0	27,5	14	10	31	25	6	15	3	5	31	68	20	11	11
325282	6959KL-25-30	24,0	31,5	16	12	35	27	6	17	3	8	35	76	24	11	13
325308	6959KL-32-30	32,0	42,0	20	16	42	27	6	19	3	15	35	95	30	11	13
325324	6959KL-40-30	39,5	51,5	26	20	52	27	10	27	3	25	35	117	35	11	17

No. 6959KR-xx-04

Clamping arm, blank

for link clamp no. 6959KL



Order no.	Article no.	B	C	dia. D	dia. E	H	H2	H3	H4	L	P	Weight [g]
400267	6959KR-16-04	16,0	34	10	8	21	2	8	3	57,0	15	104
401299	6959KR-20-04	21,0	42	14	10	31	6	15	3	74,5	20	261
400283	6959KR-25-04	24,0	48	16	12	35	6	17	3	84,5	24	399
400309	6959KR-32-04	32,0	64	20	16	42	6	19	3	109,0	30	778
400325	6959KR-40-04	39,5	79	26	20	52	10	27	3	134,5	35	1372

Design:

Hardened, tempered and burnished steel.

Note:

Formula for determining the clamping force F1:

Clamping force F1 [kN] = piston force F5 [kN] x operating lever B / load lever C

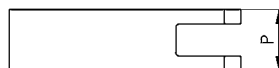
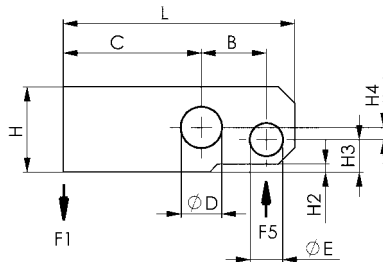



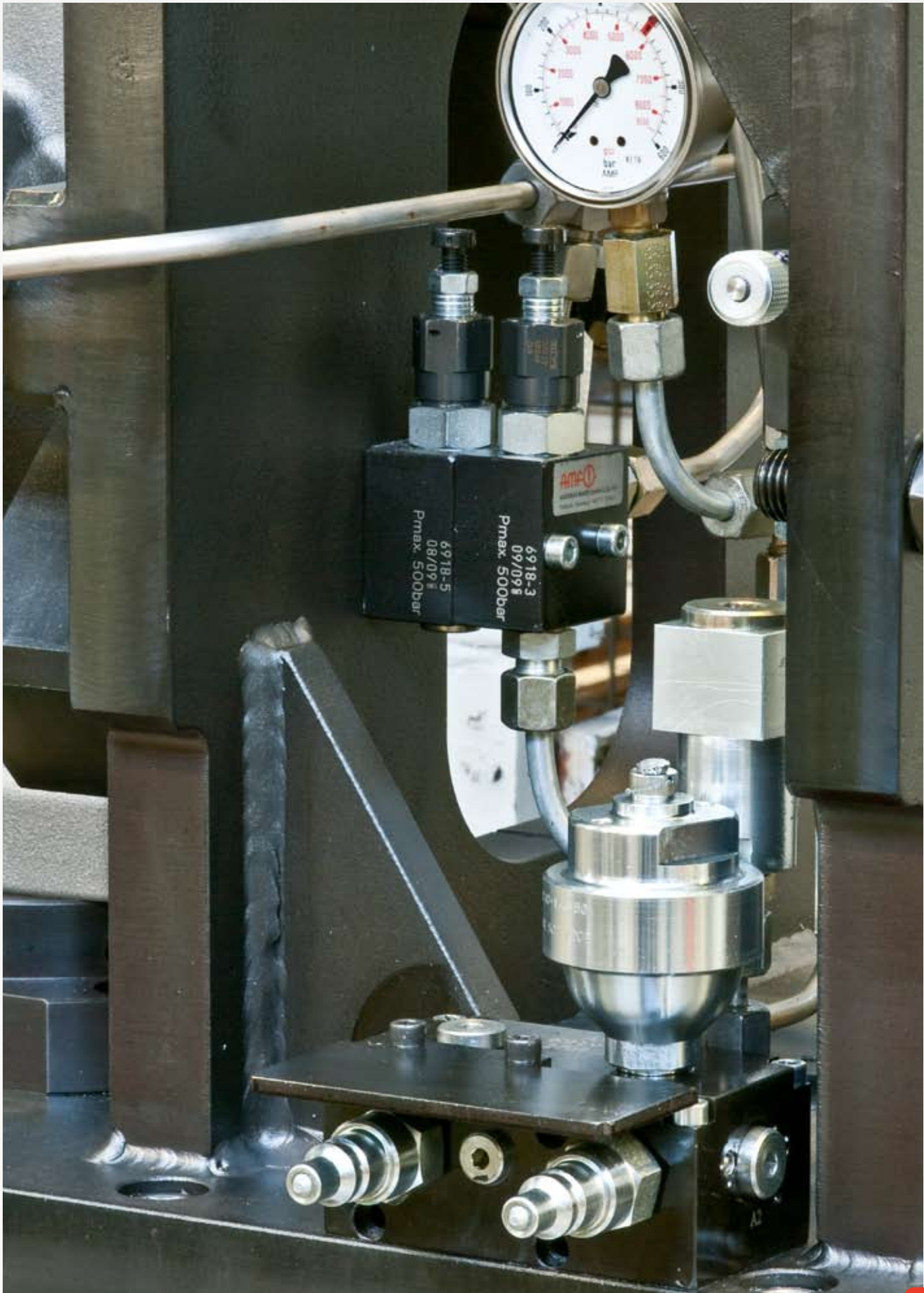

Subject to technical alterations.

TOGGLE CLAMPS FOR UNIVERSAL USE

- > operating pressure 250 bar
- > hardened and chrome-plated piston rod
- > heat-treated bolts
- > PTFE bearings
- > safe clamping or locking by clamp moving beyond deadcentre
- > oil supply via thread

PRODUCT OVERVIEW:

Type	Clamping height [mm]	Clamping stroke [mm]	Clamping force [kN]	No. of models	Operating mode
6960C	57 - 86	-	6 - 22,7	3	double-acting

PRODUCT EXAMPLES:

NO. 6960C



- > Clamping force: 6 - 22,7 kN
- > connection type: threaded connection
- > available on request

No. 6960C

Toggle Clamp, hydraulic

double acting,
max. operating pressure 250 bar.

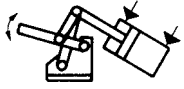

Order no.	Article no.	Clamping force at p max. resp. pD max. F1=F3 [kN]	Clamping force at p amx. resp. pD max. F2=F5 [kN]	Clamping force at p max. resp. pD max. F5 [kN]	p max. [bar]	pD max. [bar]	Weight [g]
66647	6960C-4	6	9	3	100	250	5400
66654	6960C-6	12	18	5	100	250	9600
66662	6960C-8	18	27	8	100	250	18900

Order no.	Article no.	Piston dia. [mm]	Piston rod dia. [mm]	Cylinder stroke [mm]	Piston area A1 [cm ²]	Differential area A2 [cm ²]	Oil capacity forward [cm ³]	Oil capacity backward [cm ³]
66647	6960C-4	20	12	80	3,14	2,0	25	15
66654	6960C-6	25	16	90	4,90	2,9	44	26
66662	6960C-8	32	20	120	8,00	4,9	96	59

Design:

Tempering steel, blued, with hydraulic cylinder ready for connection to standard double acting circuit (see circuit Fig. 1) or differential circuit (see circuit Fig. 2).

Application:

The clamp is particularly suitable for use in transfer and special-purpose machines. Any thrust pieces can be attached to the sturdy holding arm. With the differential circuit (see Fig. 2 below) the differential piston area A2 of the cylinder is directly connected to P of the pressure generator, while the full piston area is connected by a 3/2-way seat valve.

Features:

The clamp, of machine quality, is maintenance-free thanks to its tempered and ground shafts which run in Teflon bearings. As a result of the hydraulic cylinder operation the possible clamping force is the same as the permissible holding force. The large aperture enables unhindered workpiece handling.

Note:

Please urgently observe the maximum pressure values in the table above.

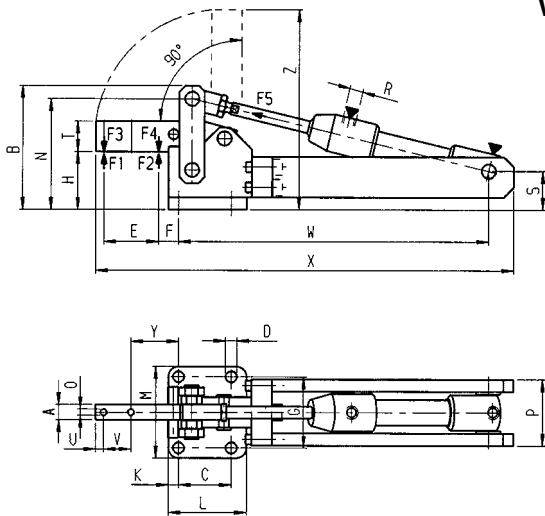

Wiring diagrams fig. 1:

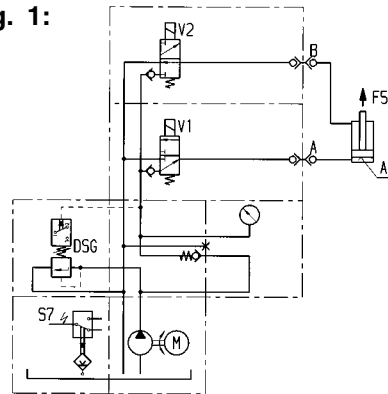
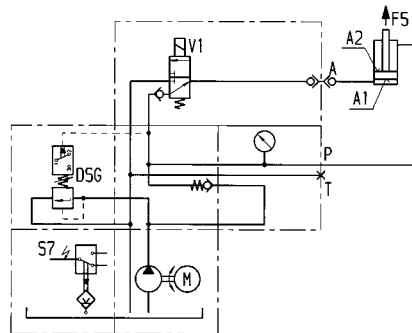

fig. 2:



Dimensions

Order no.	Article no.	A	B	C	dia. D	E	F	G	H	K	L	M	N	dia. O	P	R	S	T	U	V	W	X	Y	Z
66647	6960C-4	15	122	52	11	54	20	70	57	10,0	77,0	90	109	6,2	65	G1/4	38	30	8	27	308,0	415,0	47,0	197
66654	6960C-6	20	147	55	11	60	21	83	61	11,0	85,0	105	129	8,2	81	G1/4	41	40	12	26	353,0	466,5	52,5	216
66662	6960C-8	30	196	80	13	95	22	111	86	12,5	112,5	136	176	13,2	94	G1/4	46	60	18	40	423,5	576,0	69,5	309

Subject to technical alterations.

PULL-DOWN CLAMPS FOR 3-SIDE OR 5-SIDE MACHINING

- > clamping force up to 50 kN
- > operating pressure up to 400 bar
- > lateral clamping
- > internal clamping
- > oil supply via oil channels in device body or threaded port
- > independently adjustable clamping travel and pull-down travel

PRODUCT OVERVIEW:

Type	Clamping force [kN]	Clamping stroke [mm]	Spreading stroke [mm]	No. of models	Oil connection	Operating mode
6970	4,0 - 31,0	-	1,4 - 1,7	17	Thread / O-ring	single-acting
6790-xx-50	3,5 - 11,5	-	1,4	8	Thread / O-ring	single-acting
6970D	5,0	-	1,5	14	O-ring	double-acting
6970D	9,5	-	1,5	14	O-ring	double-acting
6972F	4,5 - 50,0	5 - 12	-	4	Thread / O-ring	single-acting
6972D	12,0 - 32,0	8 - 12	-	3	Thread / O-ring	double-acting
6973	8,9	5	-	2	Thread / O-ring	single-acting
6976	19,6 per clamping point	3	-	1	Thread / O-ring	double-acting

PRODUCT EXAMPLES:

NO. 6970



- > Clamping force: 4 - 31 kN
- > clamping inside bores for 4-side or 5-side machining.
- > Nitrided body

NO. 6972F



- > Clamping force: 4,5 - 50 kN
- > lateral clamping for 3-side machining.

NO. 6973



- > Clamping force: 8,9 kN
- > lateral clamping for 3-side machining
- > Nitrided body

Application:

These hydraulic clamping elements are especially suitable for work-pieces with complex external contours. Once clamped, full five side machining can be safely carried out. With the clamps beneath the work-piece and therefore not impeding access, the work-piece can be easily loaded and unloaded using automated handling equipment.

Design:

The actuating piston is double acting. Body and support are made of hardened steel. The clamping segments and holding bolts are made of tempered steel. All components are plasma-nitrided and are very resistant to wear and corrosion. Two-part clamping segments are serrated. Hydraulic oil supply is via O-ring ports in the base of the clamp body. Also in the clamp base is a centering hole for positioning. The O-rings and centering dowel pin are supplied with the clamp.

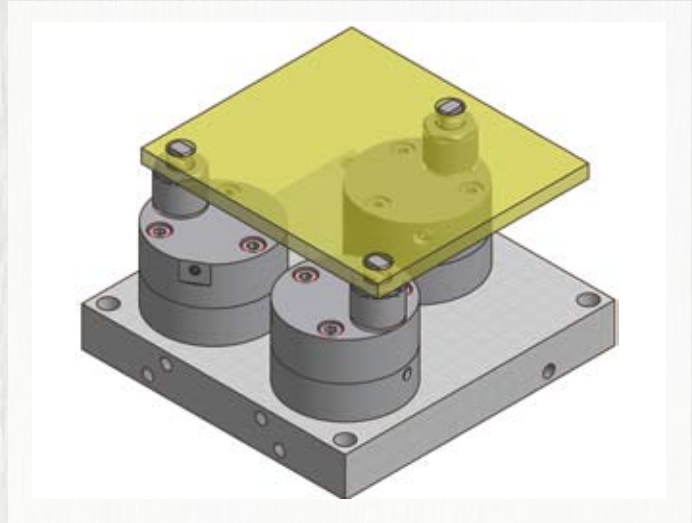

Features:

- > The clamping segments expand parallel to be in contact over the entire length of the prepared clamping hole
- > High clamping forces
- > Contact face is plasma coated with tungsten carbide to provide a hard surface and increased friction
- > Built in air sensing function
- > Clamps to not obstruct the machining area

Important notes:

- > The lateral force when inserting the workpiece must not exceed the „lateral force“ table value.
- > The radial force must be observed.
- > Please check with us for clamping of hardened workpieces or those made of GG / GGG.



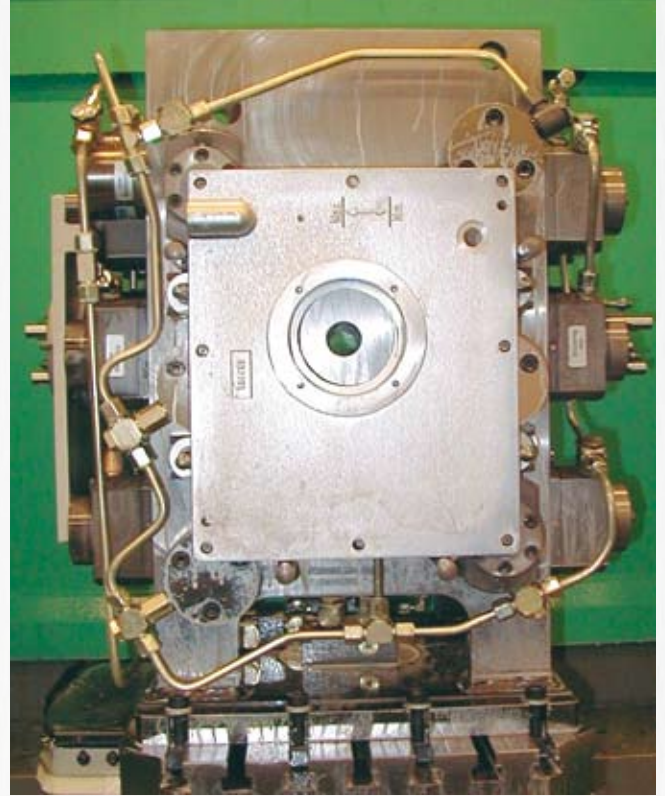
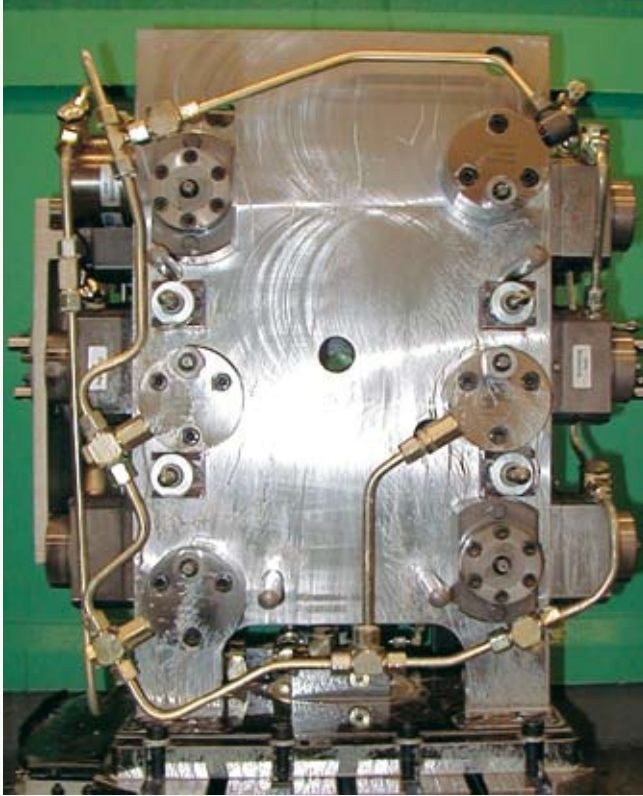

Gearbox clamping devices with and without workpiece, equipped with hydraulic pull-down clamps no. 6970 as clamping-element versions „centric“ and „eccentric“.



Workpiece clamping device, equipped with hydraulic pull-down clamps, version „centric“ at front left, and „eccentric“ at right.

No. 6970-**

Hydraulic Pull-Down Clamping Element, concentric

single acting,
max. operating pressure 350 bar,
min. operating pressure 30 bar.

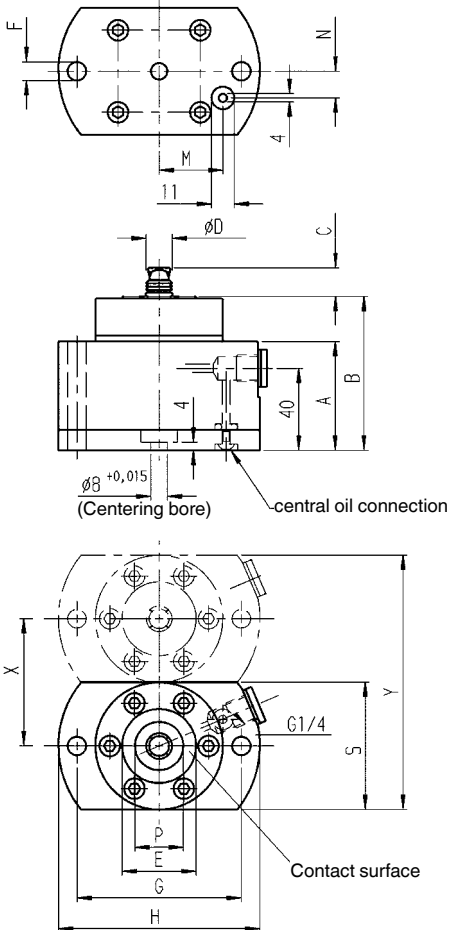
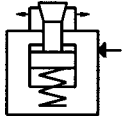

Clamping hole in workpiece

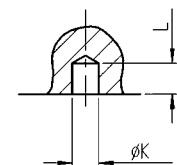

Order no.	Article no.	Clamping force vertical [kN]	K [mm]	Lateral compensation per clamp [mm]	Clamping rim height min. [mm]	Weight [g]
63651	6970-09	4	8,8-9,7	± 0,25	6	2600
60293	6970-10	4	9,8-10,7	± 0,25	6	2600
60301	6970-11	10	10,8-11,9	± 0,25	8	2600
60319	6970-12	10	12,0-12,9	± 0,25	8	2600
63677	6970-13	10	13,0-13,9	± 0,25	8	2600
60418	6970-14	10	14,0-14,9	± 0,25	8	2600
60434	6970-15	26	15,0-15,9	± 0,25	9	2800
60525	6970-16	26	16,0-16,9	± 0,25	9	2800
60426	6970-17	26	17,0-17,9	± 0,25	9	2800
63693	6970-18	26	18,0-18,9	± 0,25	9	2800
60616	6970-19	26	19,0-19,9	± 0,25	9	2800
60715	6970-20	26	20,0-20,9	± 0,25	9	2900
60723	6970-21	26	21,0-21,9	± 0,25	9	2900
63719	6970-22	26	22,0-22,9	± 0,25	9	2900
60731	6970-23	26	23,0-23,9	± 0,25	9	2900
60376	6970-24	26	24,0-24,9	± 0,25	9	2900
60384	6970-25	26	25,0-25,9	± 0,25	9	2900

Note:

For single acting clamping elements there is risk of sucking in coolant during return stroke. In this case the clamping elements has to be protected against the direct effect of coolant. The built in sinter metal breather should be covered.

On request:

Other sizes, from 7 mm clamping hole diameter: hydraulic clamping elements without pull-down effect and elements with smooth workpiece support surfaces are available.

Dimensions

Order no.	Article no.	Permissible horizontal force [kN]	Radial force of sleeve segments [kN]	Expansion of sleeve [mm]	Piston dia. [mm]	Vol. [cm ³]	Side load (unclamped) [N]
63651	6970-09	1,2	12	1,4	28	0,5	50
60293	6970-10	1,2	12	1,4	28	0,5	50
60301	6970-11	3,0	30	1,7	32	1,6	150
60319	6970-12	3,0	30	1,7	32	1,6	150
63677	6970-13	3,0	30	1,7	32	1,6	150
60418	6970-14	3,0	30	1,7	32	1,6	150
60434	6970-15	7,7	77	1,7	40	3,8	200
60525	6970-16	7,7	77	1,7	40	3,8	200
60426	6970-17	7,7	77	1,7	40	3,8	200
63693	6970-18	7,7	77	1,7	40	3,8	200
60616	6970-19	7,7	77	1,7	40	3,8	200
60715	6970-20	7,7	77	1,7	40	3,8	300
60723	6970-21	7,7	77	1,7	40	3,8	300
63719	6970-22	7,7	77	1,7	40	3,8	300
60731	6970-23	7,7	77	1,7	40	3,8	300
60376	6970-24	7,7	77	1,7	40	3,8	300
60384	6970-25	7,7	77	1,7	40	3,8	300

Bestell-Nr.	Artikel-Nr.	A	B ±0,01	C	D	E	F	G	H	L	M	N	P	S	X ±0,5	Y
63651	6970-09	53	75	9,5	8,5	36	9	80	98	10	31	13	15	62	62	124
60293	6970-10	53	75	9,5	9,5	36	9	80	98	10	31	13	15	62	62	124
60301	6970-11	53	75	14,0	10,5	36	9	80	98	15	31	13	19	62	62	124
60319	6970-12	53	75	14,0	11,5	36	9	80	98	15	31	13	19	62	62	124
63677	6970-13	53	75	14,0	12,5	36	9	80	98	15	31	13	19	62	62	124
60418	6970-14	53	75	14,0	13,5	36	9	80	98	15	31	13	19	62	62	124
60434	6970-15	53	75	16,0	14,5	36	13	90	115	17	35	15	24	62	62	124
60525	6970-16	53	75	16,0	15,5	36	13	90	115	17	35	15	24	62	62	124
60426	6970-17	53	75	16,0	16,5	36	13	90	115	17	35	15	24	62	62	124
63693	6970-18	53	75	16,0	17,5	36	13	90	115	17	35	15	24	62	62	124
60616	6970-19	53	75	16,0	18,5	36	13	90	115	17	35	15	24	62	62	124
60715	6970-20	53	75	16,0	19,5	36	13	90	115	17	35	15	28	62	62	124
60723	6970-21	53	75	16,0	20,5	36	13	90	115	17	35	15	28	62	62	124
63719	6970-22	53	75	16,0	21,5	36	13	90	115	17	35	15	28	62	62	124
60731	6970-23	53	75	16,0	22,5	62	13	90	115	17	35	15	32	62	62	124
60376	6970-24	53	75	16,0	23,5	62	13	90	115	17	35	15	32	62	62	124
60384	6970-25	53	75	16,0	24,5	62	13	90	115	17	35	15	32	62	62	124

Subject to technical alterations.

No. 6970-**-**

Hydraulic Pull-Down Clamping Element, eccentric

single acting,
max. operating pressure 150 bar,
min. operating pressure 30 bar.

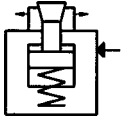

Drill pattern for central oil supply and centering

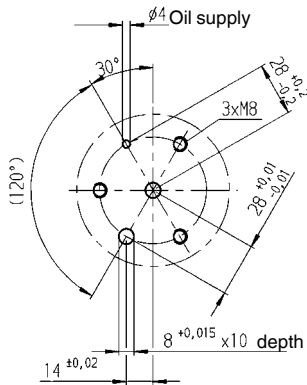

Clamping hole in workpiece

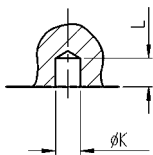

Dimensions

Order no.	Article no.	Permissible horizontal force [kN]	Radial force of sleeve segments [kN]	Expansion of sleeve [mm]	Piston dia. [mm]	Vol. [cm ³]	Side load (unclamped) [N]	A	B ±0.01	C	D	E	F	H	L	P
63669	6970-07-50	1,0	10	1,4	18	1,0	50	59	75	9,5	6,6	24	9	80	10	15
60798	6970-08-50	1,0	10	1,4	18	1,0	50	59	75	9,5	7,5	24	9	80	10	15
63685	6970-09-50	1,5	15	1,4	22	1,5	80	59	75	9,5	8,5	24	9	80	10	15
60814	6970-10-50	1,5	15	1,4	22	1,5	80	59	75	9,5	9,5	24	9	80	10	15
63701	6970-11-50	2,5	25	1,4	28	2,5	120	59	75	12	10,5	24	9	80	13	19
60830	6970-12-50	2,5	25	1,4	28	2,5	120	59	75	12	11,5	24	9	80	13	19
63727	6970-13-50	3,5	35	1,4	32	3,2	150	59	75	12	12,5	24	9	80	13	19
60822	6970-14-50	3,5	35	1,4	32	3,2	150	59	75	12	13,5	24	9	80	13	19

Order no.	Article no.	Clamping force vertical [kN]	K [mm]	Lateral compensation per clamp [mm]	Clamping rim height min. [mm]	Weight [g]
63669	6970-07-50	3,5	6,8-7,7	± 0,25	6	2600
60798	6970-08-50	3,5	7,8-8,7	± 0,25	6	2600
63685	6970-09-50	5,3	8,8-9,7	± 0,25	7	2600
60814	6970-10-50	5,3	9,8-10,7	± 0,25	7	2800
63701	6970-11-50	8,5	10,8-11,7	± 0,25	8	2800
60830	6970-12-50	8,5	11,8-12,7	± 0,25	8	2800
63727	6970-13-50	11,5	12,8-13,7	± 0,25	9	2900
60822	6970-14-50	11,5	13,8-14,7	± 0,25	9	2900

On request:

Other sizes, from 7 mm clamping hole diameter: hydraulic clamping elements without pull-down effect and elements with smooth workpiece support surfaces are available.

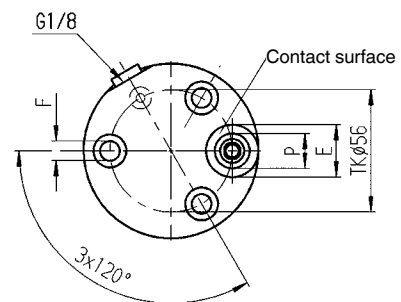
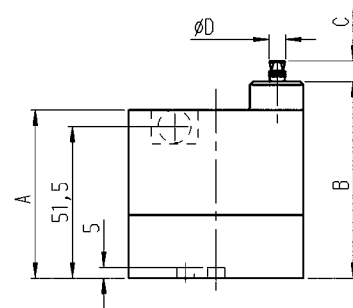
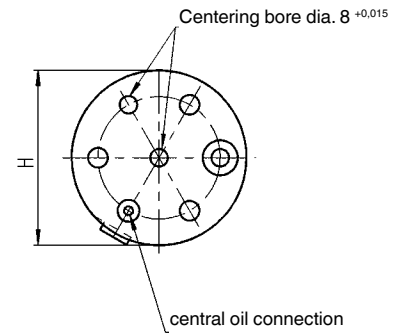

No. 6970D

Hydraulic pull-down spring clamp, eccentric

double acting,
max. operating pressure 250 bar,
min. operating pressure 40 bar.

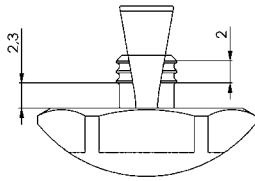
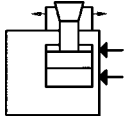

Clamping hole in workpiece

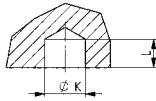

Drilling template device

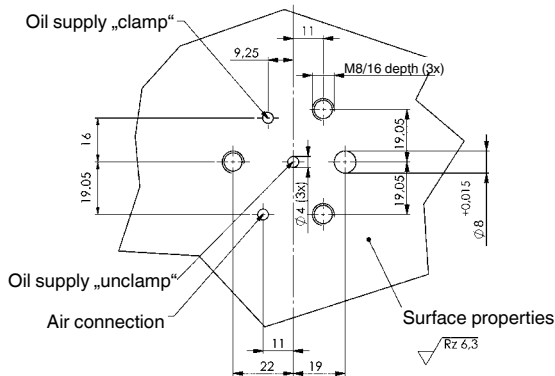

Dimensions

Order no.	Article no.	Permissible horizontal force [kN]	Radial force of sleeve segments [kN]	Expansion of sleeve [mm]	Clamping piston diameter [mm]	Vol. [cm ³]	Side load (unclamped) [N]	C	dia. D	L
323410	6970D-06-60	1,5	14	1,5	16	0,9	30	8,5	5,6	9
324384	6970D-065-60	1,5	14	1,5	16	0,9	30	8,5	6,1	9
323436	6970D-07-60	1,5	14	1,5	16	0,9	40	8,5	6,6	9
324400	6970D-075-60	1,5	14	1,5	16	0,9	40	8,5	7,1	9
323444	6970D-08-60	1,6	14	1,5	16	0,9	50	8,5	7,6	9
324392	6970D-085-60	1,6	14	1,5	16	0,9	50	9,5	8,1	10
323469	6970D-09-60	1,6	14	1,5	16	0,9	80	9,5	8,6	10
323485	6970D-10-60	1,8	14	1,5	16	0,9	80	9,5	9,6	10

Order no.	Article no.	Clamping force vertical [kN]	dia. K [mm]	Lateral compensation per clamp [mm]	Clamping rim height min. for Al-alloy [mm]	Weight [g]
323410	6970D-06-60	5,0	5,9 - 6,3	± 0,25	7	1000
324384	6970D-065-60	5,0	6,4 - 6,8	± 0,25	7	1000
323436	6970D-07-60	5,0	6,9 - 7,3	± 0,25	7	1000
324400	6970D-075-60	5,0	7,4 - 7,8	± 0,25	7	1000
323444	6970D-08-60	5,0	7,9 - 8,3	± 0,25	8	1000
324392	6970D-085-60	5,0	8,4 - 8,8	± 0,25	8	1000
323469	6970D-09-60	5,0	8,9 - 9,8	± 0,25	8	1000
323485	6970D-10-60	5,0	9,9 - 10,8	± 0,25	8	1000

Note:

The centering pin is supplied with the clamp.

On request:

Other sizes and special designs available without pull-down and as support elements.

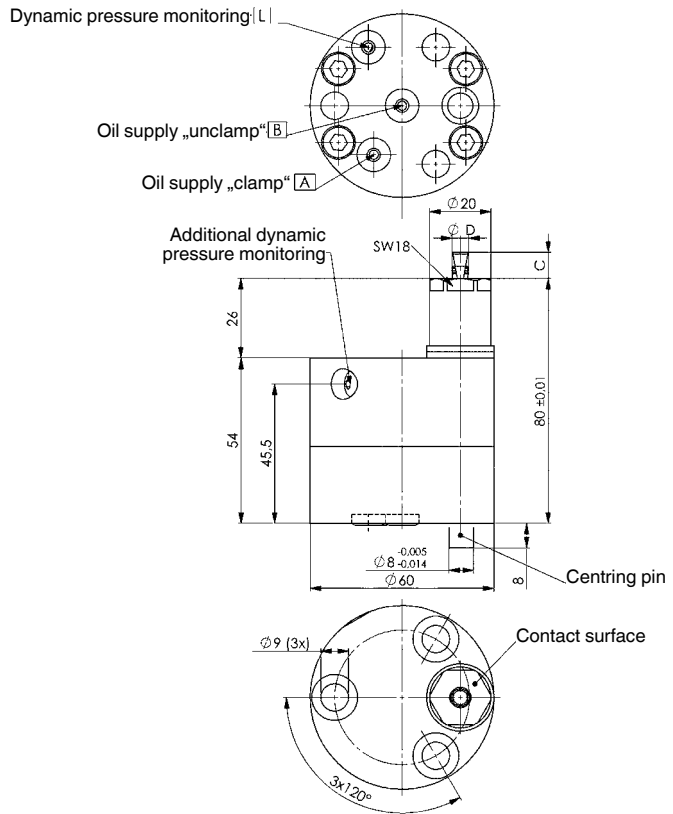



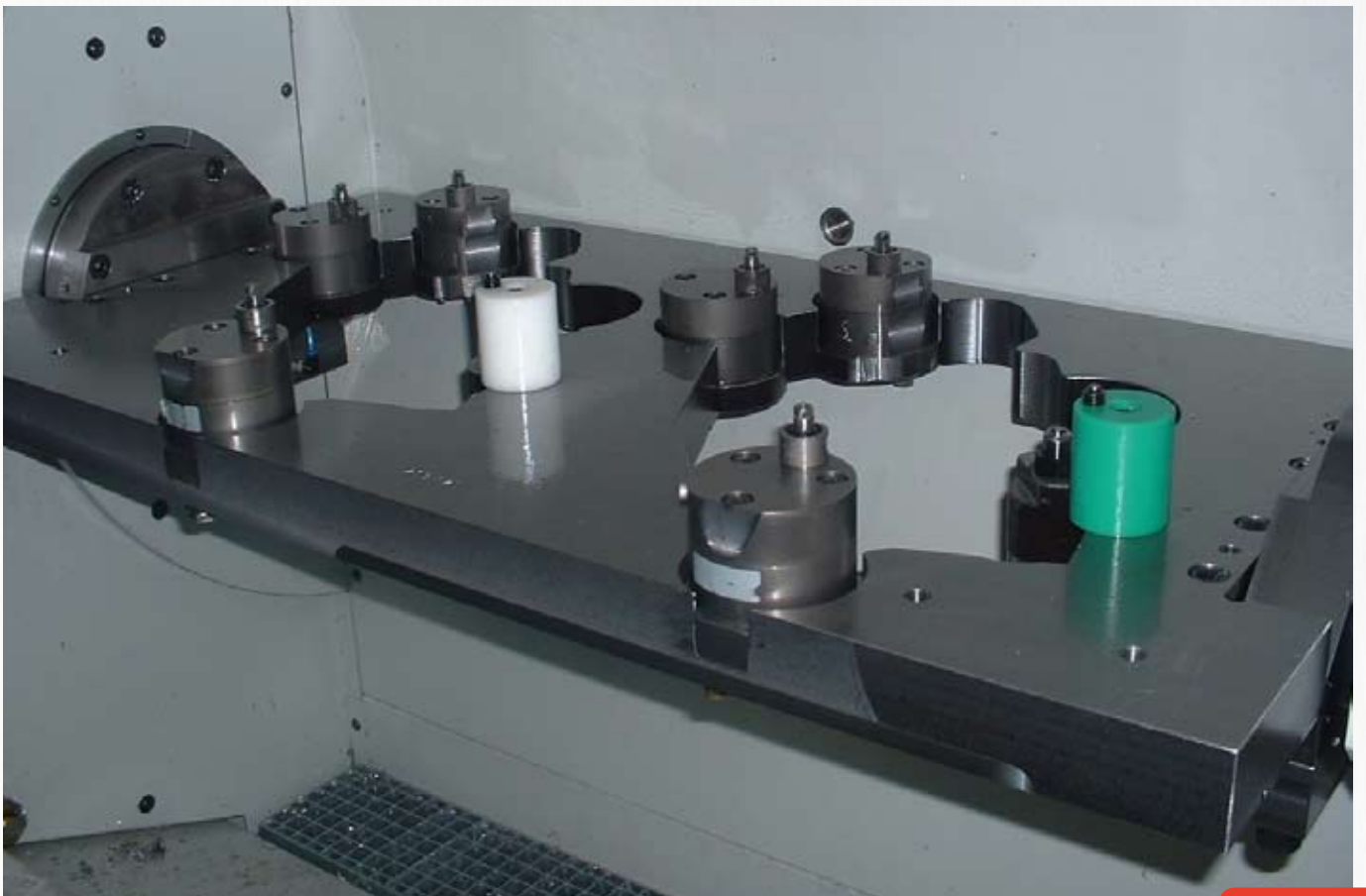

No. 6972F

Pull-Down Clamp, hydraulic

single acting, spring return,
max. operating pressure 400 bar,
min. operating pressure 40 bar.



Order no.	Article no.	Clamping force at 400 bar [kN]	Stroke H [mm]	Piston dia. [mm]	Vol. [cm ³]	Screw (2 pieces)	Md max. [Nm]	Spring force min. [N]	Weight [g]
66951	6972F-05	4,5	5	12	0,57	M8x45	21	60	670
66969	6972F-20	20,0	8	25	4	M12x80	72	160	2500
66977	6972F-32	32,0	10	32	8	M16x100	180	210	4700
66985	6972F-50	50,0	12	40	15	M20x120	350	340	8800

Design:

Cylinder body made of tempering steel, blued. Piston case-hardened and ground. Jaw exchangeable. Standard version with serrated and hardened jaw, complete with two mounting bolts (ISO), built-in return spring. Oil supply via O-ring or threaded port. All oil channels are sealed.

Application:

Pull-down clamps are used whenever clamping is possible only laterally and the workpiece nevertheless has to be held firmly on the machine tool table. The hydraulic principle enables high pressing and pull-down forces. Mounting by two bolts from above or by four bolts from the bottom.

Features:

Horizontal and vertical movement is independent of each other (no locked coupling) giving a true pull-down effect. No raising of the clamping jaw, because the clamping bolt is right behind the jaw. Suitable for incorporation in fixtures. New design of jaw connection with rubber buffer ensures sliding without any play.

Note:

The maximum pull-down stroke of the jaw must not exceed dimension G. Do not overstress mounting bolts! Observe maximum permissible torque. For sizes 20, 32 and 50 the oil channel can be closely by means of a sealing washer and a bolt ISO 4762 - M5x10 from the bottom. Jaw and piston are connected together by a joint such to avoid the introduction of a bending moment to the piston, thus increasing the element's life time. Pull-down force approx. 1/3 of respective clamping force

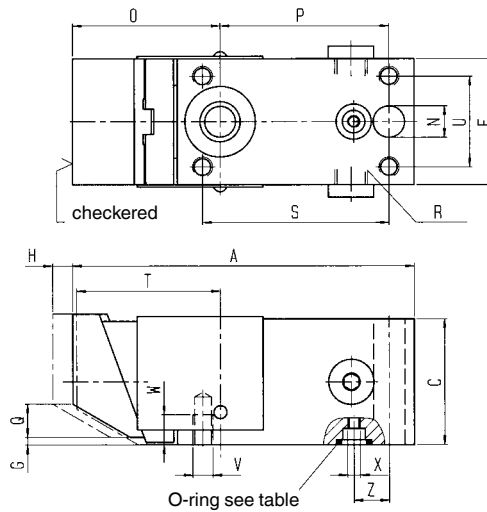

Dimensions

Order no.	Article no.	-A	C	F	G	H	N	O±0.5	P	Q	R	S	T	U	V	W	X	Z
66951	6972F-05	100,0	30	30	2	5	8,5	39,0	53	3	G1/8	59	38,0	22	M5	6	M3	13,0
66969	6972F-20	135,0	50	50	3	8	12,5	58,0	67	14	G1/4	74	57,0	36	M8	12	M5	14,0
66977	6972F-32	149,5	65	65	3	10	16,5	63,5	72	17	G1/4	83	62,5	47	M10	16	M5	17,5
66985	6972F-50	180,0	80	80	3	12	20,5	71,0	93	19	G1/4	104	70,0	60	M12	25	M5	21,0

O-ring

(included in scope of supply)

Order no.	O-ring	for size	Weight [g]
156067	4,6 x 2,0 - PU 93 Shore A	6972F-05	1
114405	9,0 x 2,5 - PU 93 Shore A	6972F-20, -32, -50	1

No. 6972D

Pull-Down Clamp, hydraulic

double acting,
max. operating pressure 400 bar.



Order no.	Article no.	Clamping force at 400 bar		Stroke H	Piston dia.	Oil capacity clamp	Oil capacity unclamp	Screw (4 pieces)	Md max.	Weight
		clamp [kN]	unclamp [kN]	[mm]	[mm]	[cm ³]	[cm ³]		[Nm]	[g]
320150	6972D-12	12	4,5	8	20	2,5	0,9	M6x50	17	1500
320168	6972D-20	20	9,6	10	25	4,9	2,5	M8x60	25	2900
320614	6972D-32	32	12,5	12	32	9,7	4,0	M10x75	46	4900

Design:

Cylinder body made of tempering steel, blued. Piston case-hardened and ground. Exchangeable jaws. Standard version with serrated and hardened jaws. Complete with 4 mounting bolts (ISO), O-ring and oil plugs, particle wiper at clamping bolt.

Application:

Pull-down clamps are used wherever the workpiece can only be laterally clamped but must be reliably secured on the fixture body. The hydraulic principle enables high pressing and pull-down forces. This clamp can be used on fixture bodies with manifold-type oil supply. The oil is then supplied through the fixture body. Sealing is achieved by an O-ring. Fastening is facilitated from above by 4 fasteners.

Features:

Quick and safe return movement, independent of the line lengths or the numbers of elements in the circuit. Independent horizontal and vertical movement (no locked coupling), giving a true pull-down effect. Lifting of the clamping jaw is prevented by the location of the clamping bolt right behind the jaw. Suitable for incorporation in fixtures. New design of jaw connection with rubber buffer ensures a sliding without any play.

Note:

The maximum pull-down stroke of the jaw must not exceed dimension G. Do not overtighten the mounting fasteners! The maximum permissible torque must not be exceeded. The bottom oil channel is plugged by a sealing washer and a ISO 4762 - M 5x10 bolt. Minimum operating pressure is 40 bar.

High variability by oil connection on two sides and bottom oil channel. Jaw and hydraulic piston are connected by a joint to prevent the induction of bending forces into the piston, thus increasing the element's service life. Pull-down force is equal to approx. 1/3 of the corresponding clamping force.

No. 6972D-12

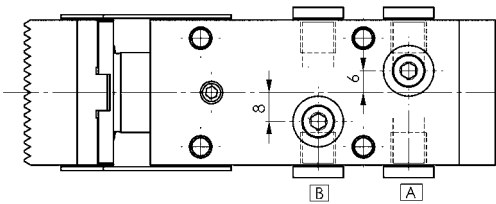

No. 6972D-20 and no. 6972D-32

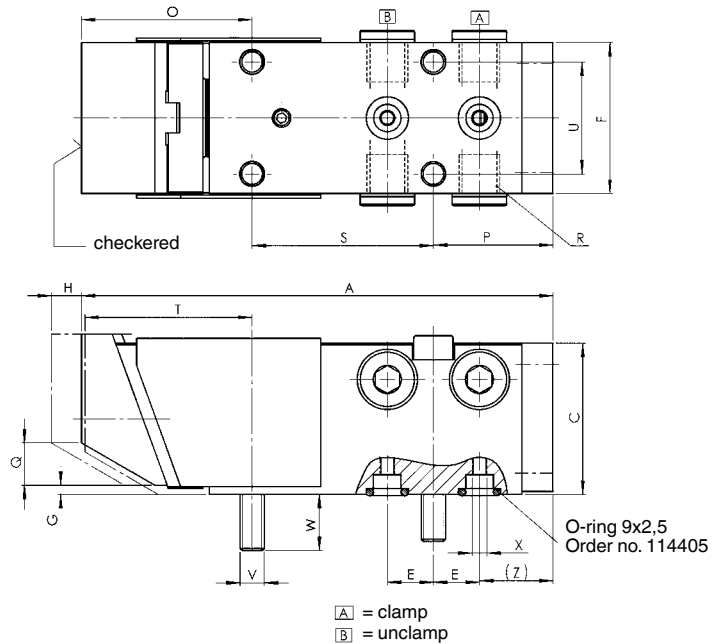

Dimensions

Order no.	Article no.	-A	C	E	F	G	H	O ±0,5	P	Q	R	S	T	U ±0,1	V	W	X	Z
320150	6972D-12	122	40	12,50	40	2	8	40,5	36,5	8,5	G1/8	45	39,5	30	M6	17,0	M5	24,0
320168	6972D-20	156	50	15,25	50	3	10	56,5	39,5	14,0	G1/4	60	55,5	37	M8	18,5	M5	24,3
320614	6972D-32	167	65	15,25	65	3	12	64,0	42,8	17,0	G1/4	60	63,0	48	M10	20,5	M5	27,5

O-ring

(included in scope of supply)

Order no.	O-ring	Weight [g]
114405	9,0 x 2,5 - PU 93 Shore A	1

No. 6977

Pull-Down Counter-Hold, mechanical

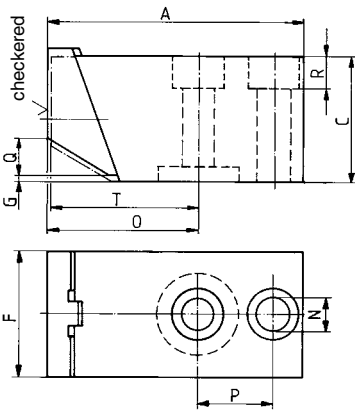

Order no.	Article no.	Holding force [kN]	Screw (2 pieces)	Weight [g]
67371	6977-05	4,5	M8x35	550
67512	6977-20	20	M12x65	1550
67421	6977-32	32	M16x80	3000
67520	6977-50	50	M20x100	5200

Design:

Cylinder body made of tempering steel, blued. Exchangeable jaws. Standard version with serrated and hardened jaw. Jaw exchangeable. Complete with two mounting bolts (ISO).

Application:

Purely a counter-hold when using a hydraulic or mechanical pull-down clamp. The workpiece is pulled down onto the machine table by the horizontal force that is applied.

Features:

The smooth clamping jaw moves always against the machine tool table surface, i.e. the stop position is always the same. Clamping on slotted table possible lengthwise and crosswise. No raising of the clamping jaw, because the clamping bolt is right behind the jaw. Suitable for incorporation in fixtures. New design of jaws connection with rubber buffer ensures sliding without any play.

Note:

The maximum pull-down stroke of the jaw must not exceed dimension G.

Dimensions

Order no.	Article no.	-A	C	F	G	N	O ±0.5	P	Q	R	T
67371	6977-05	79	30	30	2	8,5	42	26	3	8	41
67512	6977-20	102	50	50	3	12,5	60	30	14	13	59
67421	6977-32	114	65	65	3	16,5	62	37	17	18	61
67520	6977-50	133	80	80	3	20,5	68	46	19	23	67

Application example

Pull-down clamp no. 6972F-20 as vice

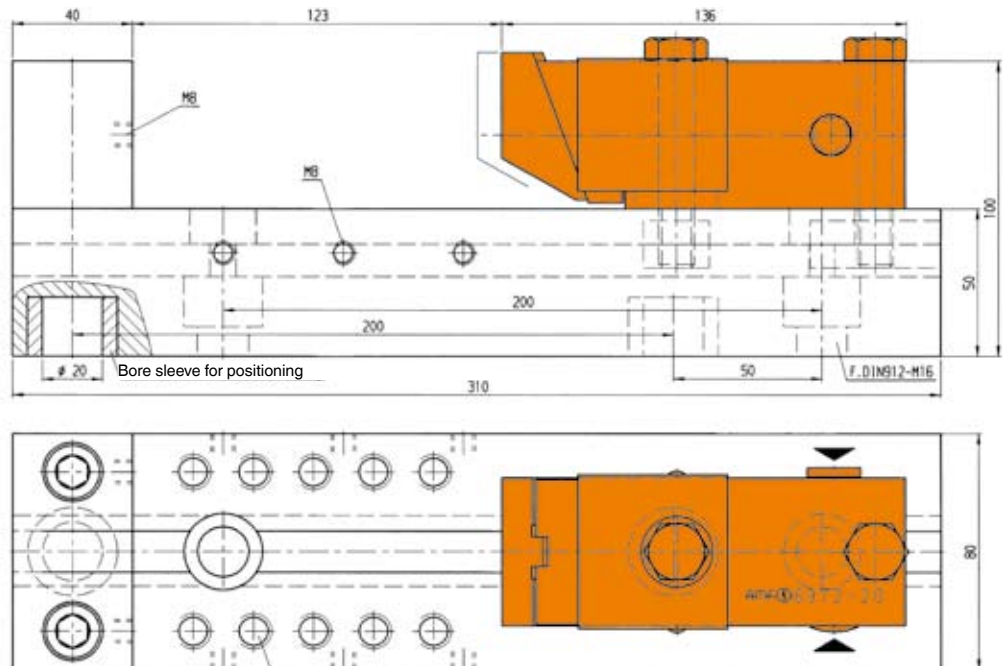

M12 for support pieces no. 6363-12-...

Subject to technical alterations.

No. 6972G

Clamping Jaws, serrated

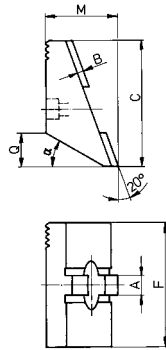

Order no.	Article no.	A	B	C	F	M	Q	alpha	Weight [g]
67025	6972G-05	6	2,7	29,5	30	22,0	3,0	15°	75
320887	6972G-12	10	2,5	40,0	40	23,0	8,5	30°	126
67165	6972G-20	10	3,0	50,0	50	31,5	14,0	30°	260
67256	6972G-32	10	3,0	65,0	65	37,0	17,5	30°	505
67322	6972G-50	10	3,0	80,0	80	39,5	19,0	30°	825

Design:

Tempering steel, hardened and tempered, with serrated clamping surface.

Application:

For all workpieces with normal clamping faces.

Note:

This clamping jaw is part of the standard equipment of pull-down clamps No. 6972D, 6972F and counter-hold 6977.

No. 6972W

Clamping Jaws, soft

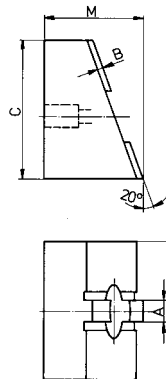

Order no.	Article no.	A	B	C	F	M	Weight [g]
67017	6972W-05	6	2,7	29,5	30	32,0	145
320903	6972W-12	10	2,5	40,0	40	33,0	277
67173	6972W-20	10	3,0	50,0	50	41,5	525
67264	6972W-32	10	3,0	65,0	65	52,0	1000
67330	6972W-50	10	3,0	80,0	80	59,5	1550

Design:

Tempering steel, unhardened, with smooth clamping surface.

Application:

These clamping jaws can be shaped into any clamping form or ground flush for sensitive workpieces.

No. 6972GR

Clamping Jaws, with clamping edge

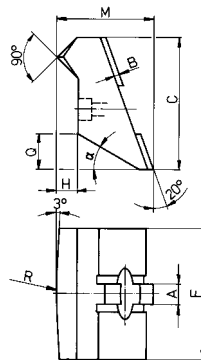

Order no.	Article no.	A	B	C	F	H	M	Q	R	alpha	Weight [g]
67009	6972GR-05	6	2,7	29,5	30	5,0	27,0	4,0	300	15°	85
321620	6972GR-12	10	2,5	40,0	40	6,5	29,5	8,5	200	30°	147
67181	6972GR-20	10	3,0	50,0	50	8,0	39,5	14,0	200	30°	300
67272	6972GR-32	10	3,0	65,0	65	10,0	47,0	17,0	300	30°	600
67348	6972GR-50	10	3,0	80,0	80	12,0	51,0	19,0	300	30°	940

Design:

Tempering steel, case-hardened and tempered, with bombed clamping surface.

Application:

Clamping jaws are particularly suitable for workpieces with hard and very uneven surfaces.



No. 6973

Pull-Down Clamp

single acting, with spring return,
max. operating pressure 350 bar.



Order no.	Article no.	Clamping force horizontal at 350 bar [kN]	Clamping force vertical at 350 bar [kN]	Stroke [mm]	Piston area [cm ²]	Vol. total [cm ³]	Weight [g]
66787	6973-09-1	9	2,2	5	2,9	1,4	481
66803	6973-09-2	9	2,2	5	2,9	1,4	399

Design:

Cylinder housing made of steel, hardened and blued. Piston rod case-hardened and ground. Clamping jaws hardened. Return spring out of stainless steel.

Application:

Universal Edge Clamp for various applications.

Features:

Small unit offering large clamping force. Oil supply by threaded ports or manifolds.

Note:

The system has to be completely vented during installation.

No. 6973-09-1

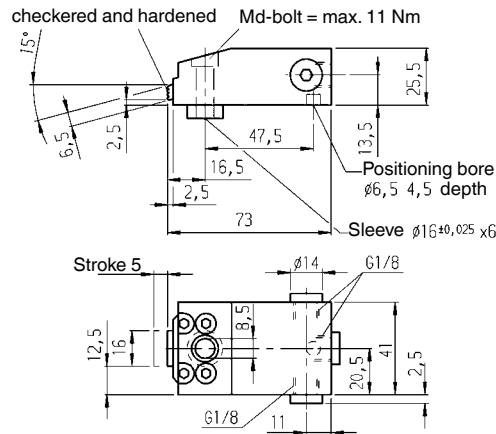

No. 6973-09-2

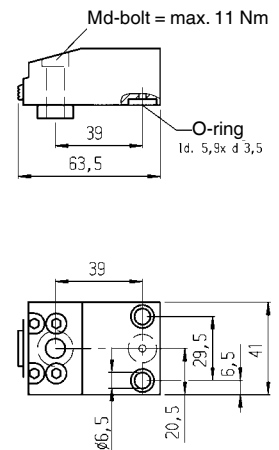

... AND THEIR SPECIFIC CHARACTERISTICS:

- > Hydraulic precision multiple-clamping system, symmetrical layout, with four clamping points. Individually adjustable. Centrally clamping.
- > Manual adjustment of clamping intervals with a pitch of 1 mm. Positive-fit connection. The use of the full clamping stroke of 3 mm allows the clamping of workpieces with nominal widths from 13 mm to 134 mm. With a clamping stroke of 1 mm, a max. nominal workpiece width of 136 mm can be clamped. Please note: Gripping jaws change these values!
- > Workpiece support surface = 104 x 6 mm, workpiece clamping surface = 104 x 12 mm. The workpiece supports are integrated in the clamping jaws and cylinder housings.
- > Jaw width = 104 mm
- > Oil is supplied centrally, optionally through two lateral connections in G 1/4 or through O-ring connections in the base plate. Oil flow is distributed evenly to the pistons via the pipe system.
- > For use on machine tables as well as in devices and quick-change systems.

THE HYDRAULIC MULTIPLE-CLAMPING SYSTEM IN DETAIL:

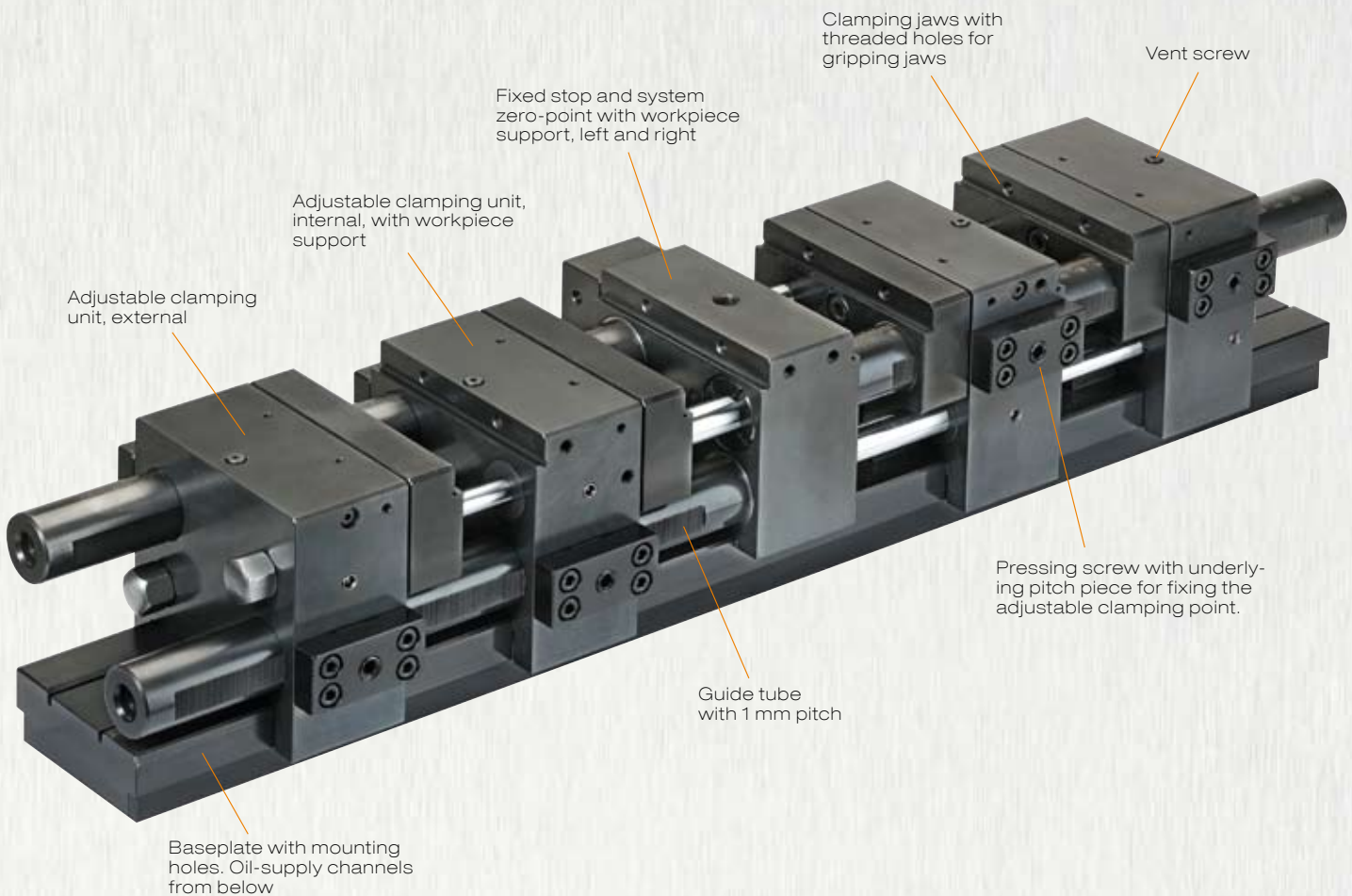

NOTE:

- > Maximum traversing speed 0.5 m/s.
- > Minimum operating pressure 40 bar.
- > The use of a hydraulic unit with a 4/3-way valve is recommended.
- > To manually adjust the clamping positions, the A and B channels must be connected to the tank (unpressurized state).
- > When programming the machines, please observe the zero offset on the multiple clamping system!!

APPLICATION:

- > Two or four workpieces on a centrally clamping device.
- > Parallel arrangement of several devices for series production.
- > Parallel arrangement of several devices for long workpieces.

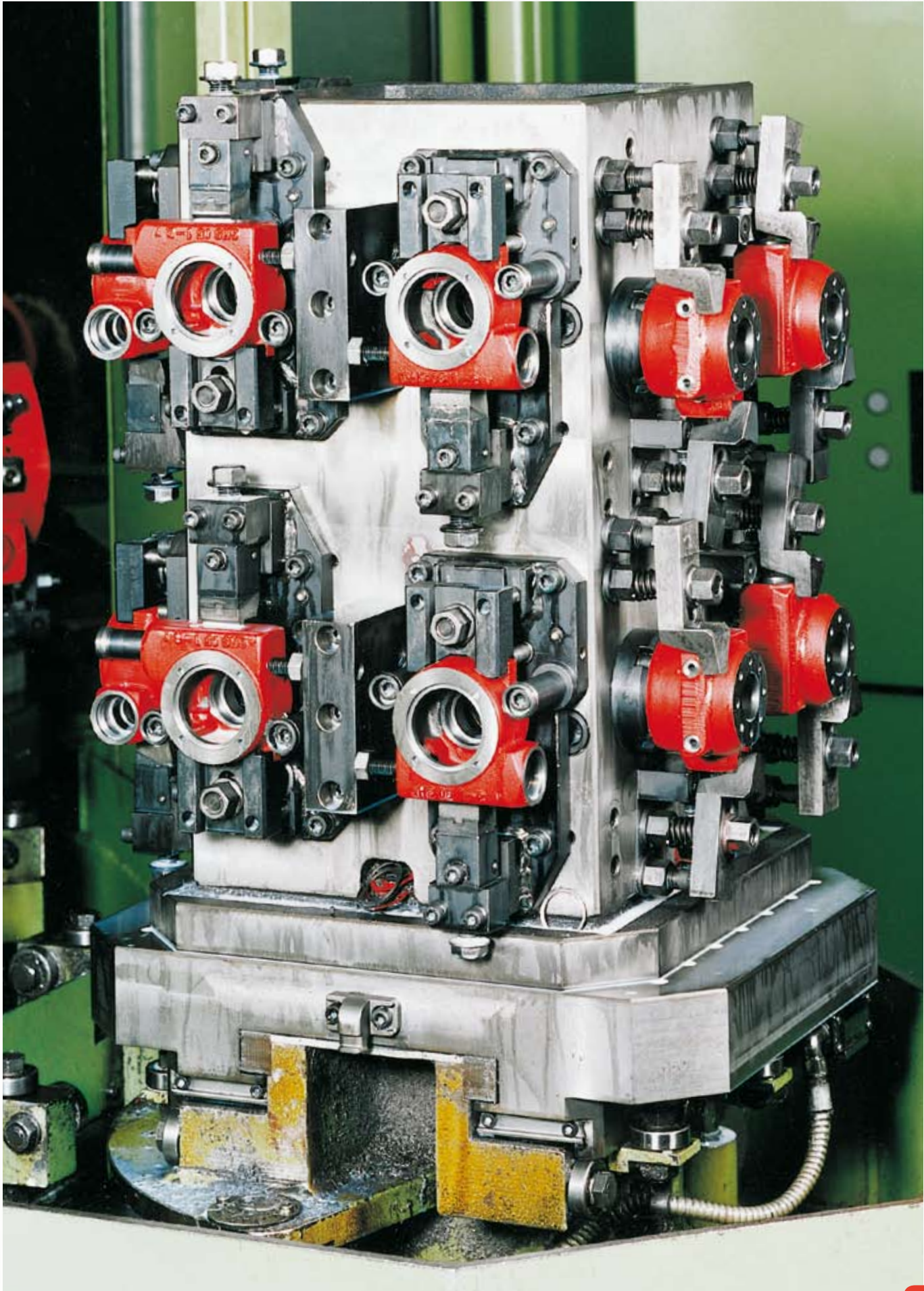

Subject to technical alterations.

SUPPORT ELEMENTS FOR STRESS-FREE CLAMPING AND LOW-VIBRATION MACHINING

- > clamping force up to 50 kN
- > operating pressure up to 400 bar
- > pistons with internal thread
- > wipers to protect against contamination
- > oil supply via oil channels in device body or via threaded port
- > various design variants
 - Block version
 - Installation version
 - Screw-in version
 - Flange version

PRODUCT OVERVIEW:

Type	Supporting force [kN]	Supporting stroke [mm]	Positioning	No. of models	Operating mode
6961F/L	8,0 - 20,0	6,0 - 10,0	Spring / Air	6	single-acting
6962F/L	8,0 - 20,0	6,0 - 10,0	Spring / Air	6	single-acting
6964F/L	4,4 - 55,6	6,5 - 19,0	Spring / Air	12	single-acting
6964H	4,4 - 17,0	6,5 - 12,5	hydraulic	5	single-acting

PRODUCT EXAMPLES:

NO. 6961F



- > Supporting force: 8 - 20 kN
- > 3 design variants

NO. 6964F



- > Supporting force: 4,4 - 55,6 kN
- > 1 design variant

NO. 6964H



- > Supporting force: 4,4 - 17 kN
- > 2 design variants

No. 6961F/L

Support Element, block type

spring advanced or air advancing,
max. operating pressure 400 bar,
min. operating pressure 50 bar.

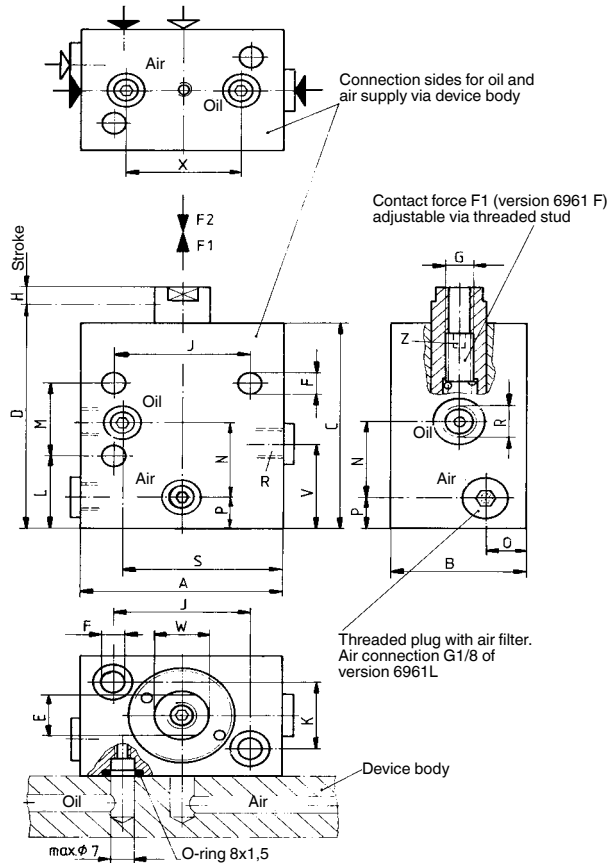
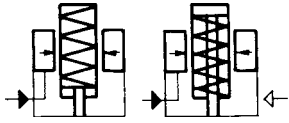

Order no.	Article no.	Contact force F1* [N]	Support force F2 [kN]	Stroke H [mm]	Vol. [cm ³]	Piston area [cm ²]	Weight [g]
65250	6961F-08	20-32	8	6	5,5	2,00	1100
65268	6961F-12	32-41	12	8	8,0	3,14	1800
65276	6961F-20	40-72	20	10	13,0	4,90	3100
65284	6961L-08	170	8	6	5,5	2,00	1100
65292	6961L-12	270	12	8	8,0	3,14	1800
65300	6961L-20	440	20	10	13,0	4,90	3100

*Article No. 6961F-**: Contact force F1 dependent on spring pretensioning and setting travel.
Article No. 6961L-**: Contact force F1 dependent on air pressure at max. 10 bar.

Design:

Cylinder body made of steel, blued. Plunger case-hardened and ground. Internal locking sleeve - System Kostyrka. Special wiper prevents contamination. Threaded support plunger. Starting position extended or retracted, depending on function. Internal parts made of stainless steel.

Application:

Support element no. 6961F-**: Plunger extended, spring adjustable contact force.
Support element no. 6961L-**: Plunger retracted, pneumatic advance spring return.
These spring or pneumatic advancing hydraulic support elements provide additional support to avoid vibration or deflection during machining. Even large workpiece tolerances can be compensated (castings). Fitted directly below a clamping point they prevent distortion of the workpiece. The support elements can be matched with clamping cylinders of same nominal size into one circuit. To prevent the support plunger from possible slackening during a clamping procedure, it is advisable to connect a sequence valve (no. 6918-2) to control the support elements. Due to this fact, the support element is locked before the clamping procedure can be activated (fig. 1). Being used as an additional support to prevent from bending and vibration, the element should be preceded by a sequence valve (no. 6918-2) in order to ensure supporting before clamping. In case the clamping force is higher than the support force, the clamping force has to be reduced by using a pressure reducing valve no. 6917 (fig. 2).

Features:

Large load capacity due to high operating pressure matched to the clamping forces of the series of clamping cylinders. Smooth contacting of the workpiece using adjustable compression springs or compressed air. Universal possible applications in each installed position. Oil and air supply optionally using drilled holes in the equipment body, seal with O-ring (8x1,5 item No. 161554) and via hose and tube connection. Simple attachment of end pieces in the thread of the piston rod.

Note:

For spring advanced types, there is risk of sucking in coolant! To avoid this, a breather piping has to be connected at the pneumatic port in order to place it to a protected area. In order to prevent that dirt and liquid enters through the support piston, the piston must be covered by a suitable cap or a supporting screw. The support elements must be properly vented! The vent port must always be on top. Insufficient ventilation will cause destruction of locking sleeve.

Wiring diagrams:

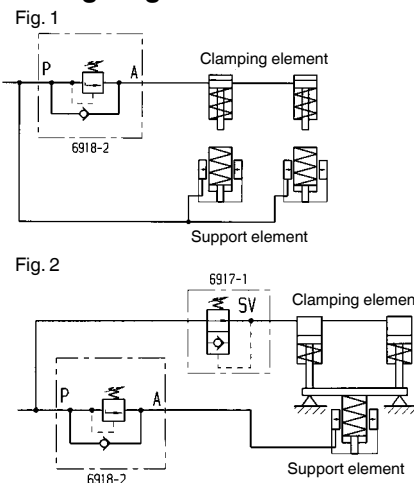
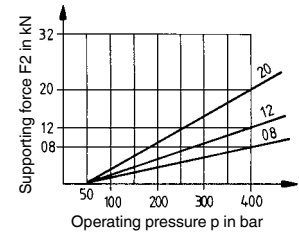

Diagram:



Dimensions

Order no.	Article no.	A	B	C	D	E	dia. F	G	J	K	L	M	N	O	P	R	S	V	dia. W	X	Z
65250	6961F-08	60	40	72	79,0	SW14	6,5	M8	40	22	28	24	28,5	12	10,5	G1/8	47	32	16	34	SW4
65268	6961F-12	70	50	86	93,5	SW17	8,5	M10	50	30	32	32	33,5	16	12,5	G1/8	56	36	20	42	SW5
65276	6961F-20	80	60	104	113,5	SW22	10,5	M12	60	40	33	40	40,0	20	14,0	G1/8	62	39	25	44	SW6
65284	6961L-08	60	40	72	79,0	SW14	6,5	M8	40	22	28	24	28,5	12	10,5	G1/8	47	32	16	34	SW4
65292	6961L-12	70	50	86	93,5	SW17	8,5	M10	50	30	32	32	33,5	16	12,5	G1/8	56	36	20	42	SW5
65300	6961L-20	80	60	104	113,5	SW22	10,5	M12	60	40	33	40	40,0	20	14,0	G1/8	62	39	25	44	SW6

No. 6962F/L

Support Element, cartridge type

spring advanced or air advancing,
max. operating pressure 400 bar,
min. operating pressure 50 bar.

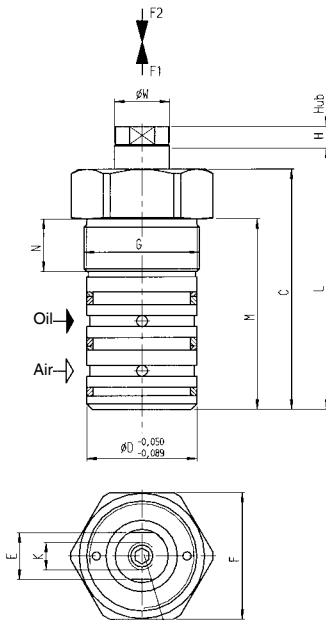
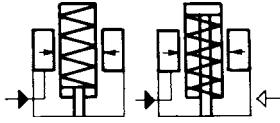

Z Contact force F1 (version 6961 F)
adjustable via threaded stud

Installation dimensions

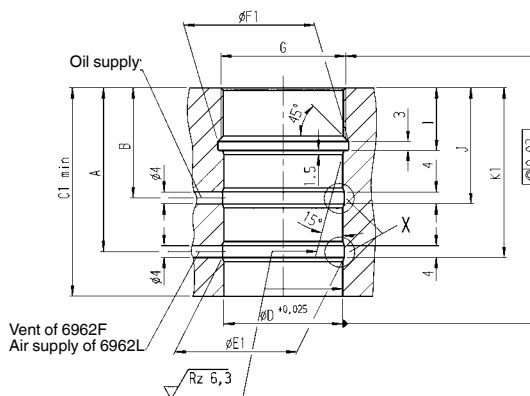

Order no.	Article no.	Contact force F1* [N]	Support force F2 [kN]	Stroke H [mm]	Vol. [cm³]	Piston area [cm²]	Weight [g]
65052	6962F-08	20-32	8	6	5,5	2,00	500
65078	6962F-12	32-41	12	8	8,0	3,14	700
65094	6962F-20	40-72	20	10	13,0	4,90	1100
65060	6962L-08	170	8	6	5,5	2,00	500
65086	6962L-12	270	12	8	8,0	3,14	700
65102	6962L-20	440	20	10	13,0	4,90	1100

*Article No. 6962F-**: Contact force F1 dependent on spring pretensioning and setting travel.
Article No. 6962L-**: Contact force F1 dependent on air pressure at max. 10 bar.

Design:

Cylinder body made of steel, blued. Plunger case-hardened and ground. Internal locking sleeve - System Kostyrka. Special wiper prevents contamination. Threaded support plunger. Starting position extended or retracted, depending on function. Internal parts made of stainless steel.

Application:

Support element no. 6962F-**: Plunger extended, spring adjustable contact force. Support element no. 6962L-**: Plunger retracted, pneumatic advance spring return. These spring or pneumatic advancing hydraulic support elements provide additional support to avoid vibration or deflection during machining. Even large workpiece tolerances can be compensated (castings). Fitted directly below a clamping point they prevent distortion of the workpiece. The support elements can be matched with clamping cylinders of same nominal size into one circuit. To prevent the support plunger from possible slackening during a clamping procedure, it is advisable to connect a sequence valve (no. 6918-2) to control the support elements. Due to this fact, the support element is locked before the clamping procedure can be activated (fig. 1, page 96). Being used as an additional support to prevent from bending and vibration, the element should be preceded by a sequence valve (no. 6918-2) in order to ensure supporting before clamping. In case the clamping force is higher than the support force, the clamping force has to be reduced by using a pressure reducing valve no. 6917.

Features:

Rigid support element due to high operating pressure, matching the forces of clamping cylinders. Smooth contacting of the workpiece by adjustable spring or pneumatic pressure. The threaded type allows to fit the work supports in fixtures with restricted space. Hydraulic and pneumatic connections are made through channels in fixture body. Easy use of contact bolts in threaded support plunger.

Note:

For spring advanced types, there is risk of sucking in coolant! To avoid this, a breather piping has to be connected at the pneumatic port in order to place it to a protected area. In order to prevent that dirt and liquid enters through the support piston, the piston must be covered by a suitable cap or a supporting screw. The support elements must be properly vented! The vent port must always be on top. Insufficient ventilation will cause destruction of locking sleeve.

Dimensions

Order no.	Article no.	C	dia. D	E	F	G	K	L	M	N	dia. W	Z
65052	6962F-08	74	36	SW14	SW41	M38x1,5	M 8	81,0	57	12,5	16	SW4
65078	6962F-12	87	40	SW17	SW46	M42x1,5	M10	94,5	69	19,0	20	SW5
65094	6962F-20	104	45	SW22	SW50	M48x1,5	M12	113,5	85	22,0	25	SW6
65060	6962L-08	74	36	SW14	SW41	M38x1,5	M8	81,0	57	12,5	16	SW4
65086	6962L-12	87	40	SW17	SW46	M42x1,5	M10	94,5	69	19,0	20	SW5
65102	6962L-20	104	45	SW22	SW50	M48x1,5	M12	113,5	85	22,0	25	SW6

Dimensions table for reception hole (installation dimensions)

Order no.	Article no.	A	B	C1 min.	dia. D H7	dia. E1	dia. F1	G	I	J	K1
65052	6962F-08	44,5	27,5	58	36	37	40	M38x1,5	14,5	29,5	46,5
65078	6962F-12	55,0	37,0	70	40	41	44	M42x1,5	21,0	39,0	57,0
65094	6962F-20	71,0	48,0	86	45	46	50	M48x1,5	24,0	50,0	73,0
65060	6962L-08	44,5	27,5	58	36	37	40	M38x1,5	14,5	29,5	46,5
65086	6962L-12	55,0	37,0	70	40	41	44	M42x1,5	21,0	39,0	57,0
65102	6962L-20	71,0	48,0	86	45	46	50	M48x1,5	24,0	50,0	73,0

Diagram:

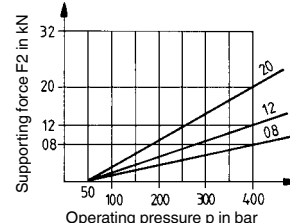

No. 6964F

Support Element, base-flange-mounting

Normally extended. Spring advanced, max. operating pressure 350 bar, min. operating pressure 50 bar.

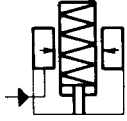

Order no.	Article no.	Contact force F1 [N]	Support force at 350 bar [kN]	Stroke C [mm]	Vol. [cm ³]	Weight [g]
66852	6964F-04	4,5 - 9,0	4,4	6,5	0,16	281
66878	6964F-11	9,0 - 26,5	11,0	9,5	0,33	840
66894	6964F-33	40 - 80	33,4	12,5	1,64	2019
66910	6964F-55	49 - 71	55,6	19,0	4,26	4291

Design:

Cylinder body made of tempered steel. Support plunger with internal thread case-hardened and ground. Wiper to protect against dirt and cutting fluid. Internal parts made of stainless steel.

Application:

The support element is used as an extra support to prevent sagging and vibration of a workpiece.

Features:

Element with high load capacity and low height. Spring extension: the plunger is normally extended. Variable spring setting permits sensitive adjustment of contact force.

Note:

Support plunger must be protected against the entry of dirt and cutting fluid by fitting a set screw or plug. When installing, ensure that all air is bled from the system. Insufficient ventilation will cause destruction of locking sleeve.

Diagrams

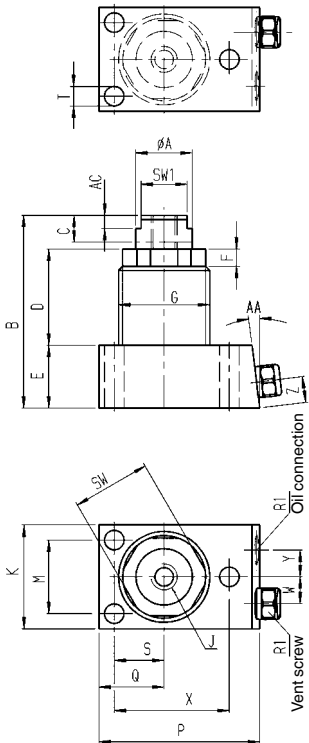
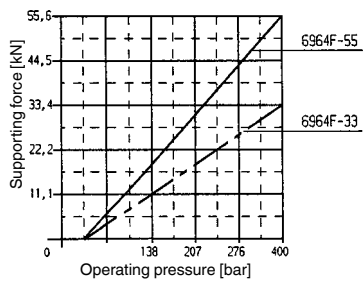
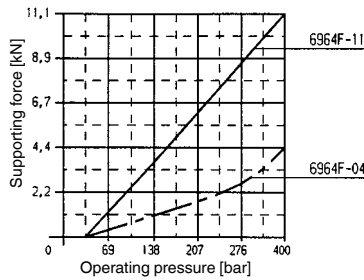

Dimensions

Order no.	Article no.	A	B	D	E	F	G	SW	SW1	J	K	M	P	Q	R1	S	T	W	X	Y	Z	AA	AC
66852	6964F-04	16,0	56,0	24,5	24,0	5,5	M26x1,5	23	-	M8x1,25x5	33,5	24,5	44,5	17,5	G1/8	13,0	5,5	9	31,0	9	10	7°	-
66878	6964F-11	20,5	70,5	33,0	25,0	6,5	M35x1,5	30	-	M10x1,50x9	41,0	30,0	59,0	24,0	G1/8	18,0	7,0	10	43,0	10	10	7°	-
66894	6964F-33	38,0	107,0	68,5	25,0	12,5	Ø 57	50	28,5	M12x1,75x15	63,5	52,5	76,0	31,5	G1/8	26,0	7,0	16	61,0	16	10	-	4
66910	6964F-55	51,0	133,0	76,0	31,5	12,5	Ø 76	70	41,5	M16x2,00x22	89,0	73,0	97,0	44,5	G1/8	36,5	9,0	24	81,5	24	10	-	4

Subject to technical alterations.

No. 6964L

Support Element, base-flange-mounting

Normally retracted. Air advanced, max. operating pressure 350 bar, min. operating pressure 50 bar.

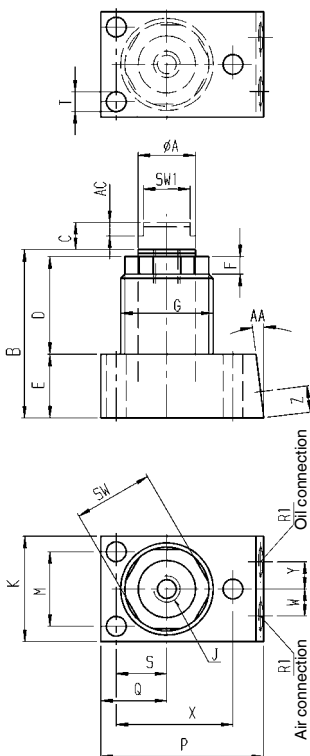
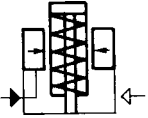

Order no.	Article no.	Contact force F1 [N]	Support force at 350 bar [kN]	Stroke C [mm]	Vol. [cm ³]	Weight [g]
66936	6964L-04	17,5*	4,4	6,5	0,16	255
66621	6964L-11	35,5*	11,0	9,5	0,33	840
66688	6964L-33	89,0*	33,4	12,5	1,64	2023
66704	6964L-55	253,3*	55,6	19,0	4,26	4300

* Contact force with 1.7 bar air pressure.

Design:

Cylinder body made of tempered steel. Support plunger with internal thread case-hardened and ground. Wiper to protect against dirt and cutting fluid. Internal parts made of stainless steel.

Application:

The support element is used as an extra support to prevent sagging and vibration of a workpiece.

Features:

Element with high load capacity and low height. Pneumatic: the plunger is normally retracted. Sensitive adjustment of contact force by varying the air pressure.

Note:

Support plunger must be protected against the entry of dirt and cutting fluid by fitting a set screw or plug. When installing, ensure that all air is bled from the system. Insufficient ventilation will cause destruction of locking sleeve.

Diagrams:

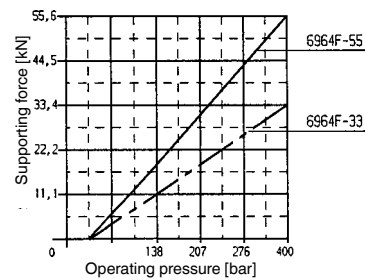
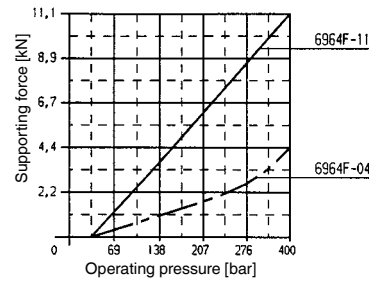

Dimensions

Order no.	Article no.	A	B	D	E	F	G	SW	SW1	J	K	M	P	Q	R1	S	T	W	X	Y	Z	AA	AC
66936	6964L-04	16,0	49	25,0	24,0	5,5	M26x1,5	23	-	M6x1,00x7,5	33,5	24,5	44,5	17,5	G1/8	13,0	5,5	9	31,0	9	10	7°	-
66621	6964L-11	20,5	61	33,0	25,0	6,5	M35x1,5	30	-	M8x1,25x6,0	41,0	30,0	59,0	24,0	G1/8	18,0	7,0	10	43,0	10	10	7°	-
66688	6964L-33	38,0	98	68,5	25,0	12,5	Ø 57	50	28,5	M12x1,75x15,0	63,5	52,5	76,0	31,5	G1/8	26,0	7,0	16	61,0	16	10	-	4
66704	6964L-55	51,0	114	76,0	31,5	12,5	Ø 76	70	41,5	M16x2,00x20,0	89,0	73,0	97,0	44,5	G1/8	36,5	9,0	24	81,5	24	10	-	4

Subject to technical alterations.



No. 6964H

Support Element, base-flange-mounting

Normally retracted. Hydraulic advanced.
Spring force for contact,
max. operating pressure 350 bar,
min. operating pressure 50 bar.

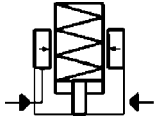

Order no.	Article no.	Contact force F1 [N]	Support force at 350 bar [kN]	Stroke C [mm]	max. oil flow rate [l/min.]	Vol. [cm ³]	Weight [g]
66746	6964H-11-2	13,5-44,5	11	6,5	2,13	3,0	845
325878	6964H-17-3	26,5 - 53,5	17	12,5	2,13	10,5	1633

Design:

Cylinder body made of tempered steel. Support plunger with internal thread case-hardened and ground. Wiper to protect against dirt and cutting fluid. Internal parts made of stainless steel.

Application:

The support element is used as an extra support to prevent sagging and vibration of a workpiece.

Features:

Element with high load capacity and low height. Hydraulic and spring: the plunger is normally retracted. When pressure is applied, the support pin advances with a weak spring-applied force to contact the workpiece. The spring force varies with the stroke. As the hydraulic pressure rises, the support plunger is hydraulically clamped. When the pressure is released, the support plunger returns to the retracted position. Very high repeatability ensures optimum production quality.

Note:

Support plunger must be protected against the entry of dirt and cutting fluid by fitting a set screw or plug. When installing, ensure that all air is bled from the system. Insufficient ventilation will cause destruction of locking sleeve.

Diagrams:

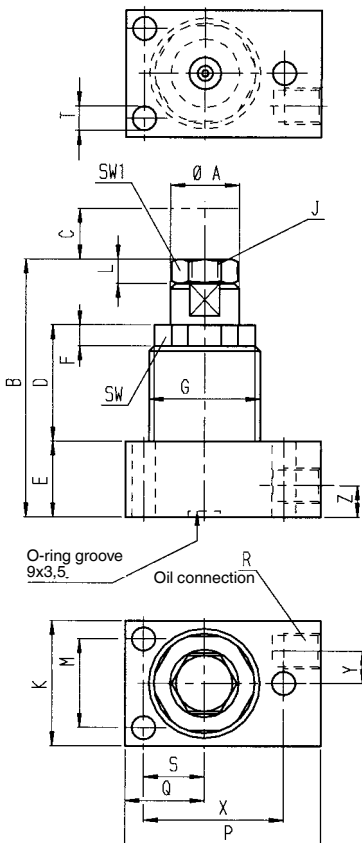
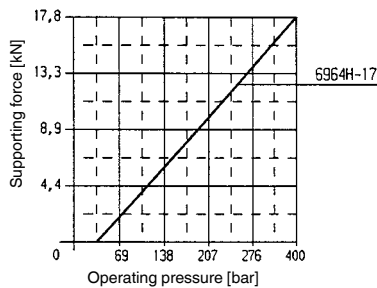
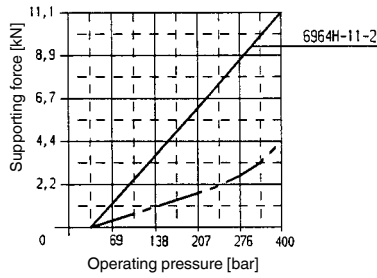

Dimensions

Order no.	Article no.	A	B	D	E	F	G	SW	SW1	J	K	L	M	P	Q	R	S	T	X	Y	Z
66746	6964H-11-2	20,5	82,0	33	31,5	9,0	M35x1,5	30	19	M12x1,75x6,5	41,5	5	30,0	58,5	23,5	G1/8	18	7	43,0	10,5	10
325878	6964H-17-3	38,0	82,5	40	25,0	12,5	M60x1,5	54	19	M12x1,75x6,5	73,0	5	52,5	81,0	36,5	G1/8	26	7	62,5	16,0	10

Subject to technical alterations.

No. 6964F

Support Element, cartridge type

Normally extended. Spring advanced, max. operating pressure 350 bar, min. operating pressure 50 bar.

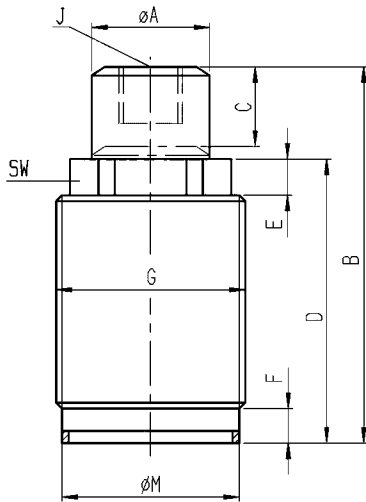
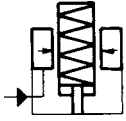

Order no.	Article no.	Contact force F1 [N]	Support force at 350 bar [kN]	Stroke C [mm]	Vol. [cm ³]	Tightening torque [Nm]	Weight [g]
165092	6964F-04-1	4,5-9,0	4,4	6,5	0,16	40,5	340
165100	6964F-11-1	9,0-26,5	11,0	9,5	0,33	40,5	340

Design:

Cylinder body made of tempered steel. Support plunger with internal thread case-hardened and ground. Wiper to protect against dirt and cutting fluid. Internal parts made of stainless steel. Oil supply by manifold.

Application:

The support element is used as an extra support to prevent sagging and vibration of a workpiece.

Features:

Element with high load capacity and low height. Spring extension: the plunger is normally extended. Variable spring setting permits sensitive adjustment of contact force.

Note:

Support plunger must be protected against the entry of dirt and cutting fluid by fitting a set screw or plug. When installing, ensure that all air is bled from the system. Insufficient ventilation will cause destruction of locking sleeve.

Dimensions

Order no.	Article no.	A	B	D	E	F	G	J	M	SW
165092	6964F-04-1	16,0	47,5	40,5	5,5	7,5	M26 x 1,5	M8x1,25x7,5	24	23
165100	6964F-11-1	20,5	62,0	49,5	6,5	8,5	M35 x 1,5	M10x1,50x11,5	31	30

Diagram:

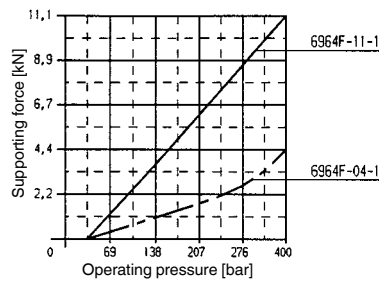

Installation drawing

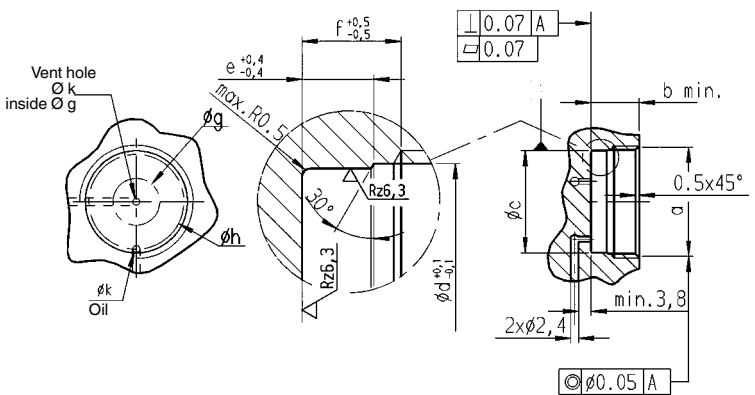

Installation dimensions

Order no.	Article no.	a	b	c	d	e	f	g	h	k
165092	6964F-04-1	M26 x 1,5-6H	15,5	24,20 ±0,025	24,5	5,7	7,0	7,5	20,4	1,6 ±0,1
165100	6964F-11-1	M35 x 1,5-6H	16,4	31,16 ±0,075	33,5	6,7	8,0	14,0	26,5	1,6 ±0,1

Subject to technical alterations.

No. 6964L

Support Element, cartridge type

Normally extended. Air advanced, max. operating pressure 350 bar, min. operating pressure 50 bar.

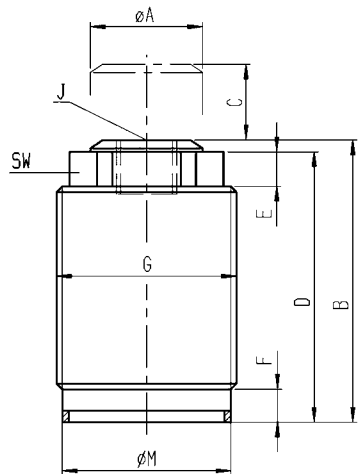
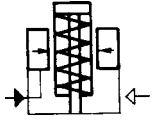

Order no.	Article no.	Contact force F1 [N]	Support force at 350 bar [kN]	Stroke C [mm]	Vol. [cm³]	Tightening torque [Nm]	Weight [g]
165167	6964L-04-1	17,5*	4,4	6,5	0,16	40,5	340
165183	6964L-11-1	35,5*	11,0	9,5	0,33	40,5	340

* Contact force with 1.7 bar air pressure.

Design:

Cylinder body made of tempered steel. Support plunger with internal thread case-hardened and ground. Wiper to protect against dirt and cutting fluid. Internal parts made of stainless steel. Oil/Air supply by manifold.

Application:

The support element is used as an extra support to prevent sagging and vibration of a workpiece.

Features:

Element with high load capacity and low height. Pneumatic: the plunger is normally retracted. Sensitive adjustment of contact force by varying the air pressure.

Note:

Support plunger must be protected against the entry of dirt and cutting fluid by fitting a set screw or plug. When installing, ensure that all air is bled from the system. Insufficient ventilation will cause destruction of locking sleeve.

Dimensions

Order no.	Article no.	A	B	D	E	F	G	J	M	SW
165167	6964L-04-1	16,0	41,0	40,5	5,5	7,5	M26x1,5	M6x1,00x7,5	24	23
165183	6964L-11-1	20,5	52,5	49,5	6,5	8,5	M35x1,5	M8x1,25x6	31	30

Diagram

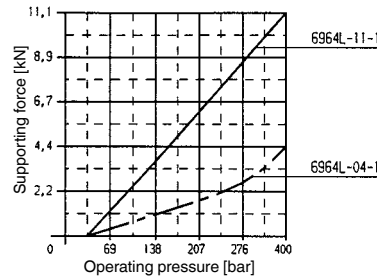

Installation drawing

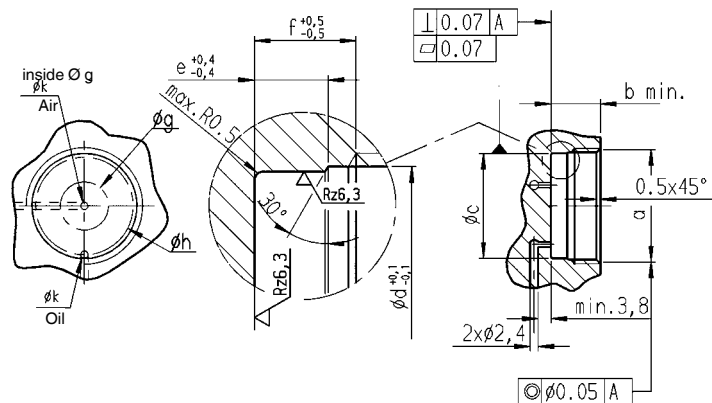

Installation dimensions

Order no.	Article no.	a	b	c	d	e	f	g	h	k
165167	6964L-04-1	M26x1,5-6H	15,5	24,2 ± 0,025	24,5	5,7	7,0	7,5	20,4	1,6 ± 0,1
165183	6964L-11-1	M35x1,5-6H	16,4	31,16 ± 0,075	33,5	6,7	8,0	14,0	26,5	1,6 ± 0,1

Subject to technical alterations.

No. 6964H

Support Element, cartridge type

Normally retracted. Hydraulic advanced.
Spring force for contact,
max. operating pressure 350 bar,
min. operating pressure 50 bar.

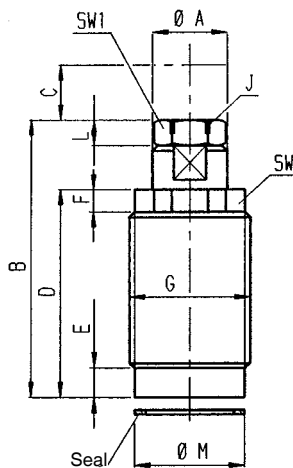
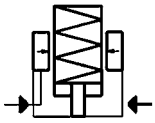

Order no.	Article no.	Contact force F1 [N]	Support force at 350 bar [kN]	Stroke C [mm]	max. oil flow rate [l/min.]	Vol. [cm³]	Tightening torque [Nm]	Weight [g]
165225	6964H-04-1	4,4-26,7	4,4	6,5	2,13	2,5	40,5	340
66720	6964H-11-1	13,5-44,5	11,0	6,5	2,13	3,0	54,0	340
165241	6964H-17-1	27,0-53,0	17,0	12,5	2,13	10,5	136,0	340

Design:

Cylinder body made of tempered steel. Support plunger with internal thread case-hardened and ground. Wiper to protect against dirt and cutting fluid. Internal parts made of stainless steel. Oil supply by manifold.

Application:

The support element is used as an extra support to prevent sagging and vibration of a workpiece.

Features:

Element with high load capacity and low height. Hydraulic and spring: the plunger is normally retracted. When pressure is applied, the support pin advances with a weak spring-applied force to contact the workpiece. The spring force varies with the stroke. As the hydraulic pressure rises, the support pin is hydraulically clamped. When the pressure is released, the support pin returns to the retracted position. Very high repeatability ensures optimum production quality.

Note:

Support plunger must be protected against the entry of dirt and cutting fluid by fitting a set screw or plug. When installing, ensure that all air is bled from the system. Insufficient ventilation will cause destruction of locking sleeve.

Dimensions

Order no.	Article no.	A	B	D	E	F	G	J	L	M	SW	SW1
165225	6964H-04-1	16,0	53	42,1	7,0	5,5	M26x1,5	M8x1,25x5,0	3,5	23,3	23	13
66720	6964H-11-1	20,5	72	54,7	9,5	9,0	M35x1,5	M12x1,75x6,5	5,0	29,7	30	19
165241	6964H-17-1	38,0	72	54,7	6,5	12,5	M60x1,5	M12x1,75x6,5	5,0	54,9	54	19

Diagrams

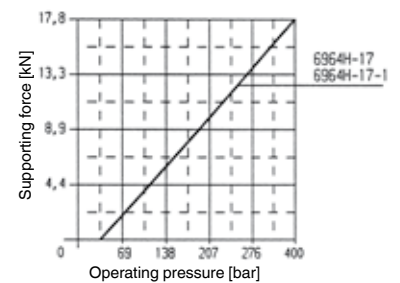
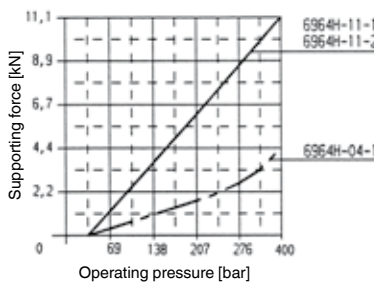

Installation drawing No. 6964H-04-1 and -11-1

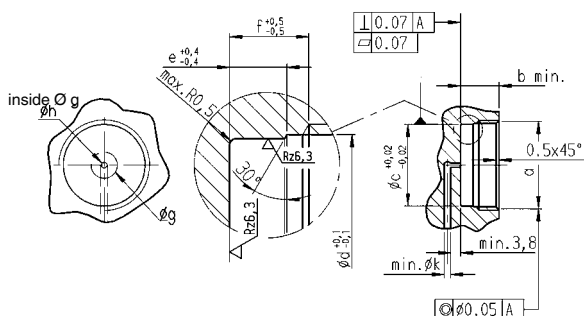

Installation drawing No. 6964H-17-1

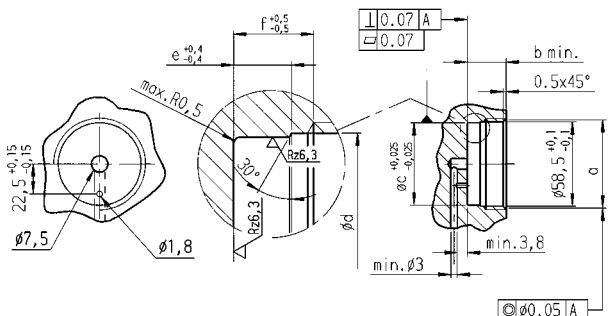

Installation dimensions

Order no.	Article no.	a	b	c	d	e	f	g	h	k
165225	6964H-04-1	M26x1,5-6H	14,5	23,44	24,5 ±0,1	4,5	6,0	7,5	1,6 ±0,3	2
66720	6964H-11-1	M35x1,5-6H	19,0	29,90	33,5 ±0,1	5,0	6,4	19,0	3,0	3
165241	6964H-17-1	M60x1,5-6H	15,0	55,00	58,5 ±0,1	4,0	5,3	-	-	-

Nr. 6964H-xx-20
 Splash protection

Order no.	Article no.	Weight [g]
326520	6964H-04-20	6
326546	6964H-11-20	12
326561	6964H-17-20	33



Application:

For protection against entry of chips and splash water.

Note:

Use only for hydraulic support element. Observe mounting position!

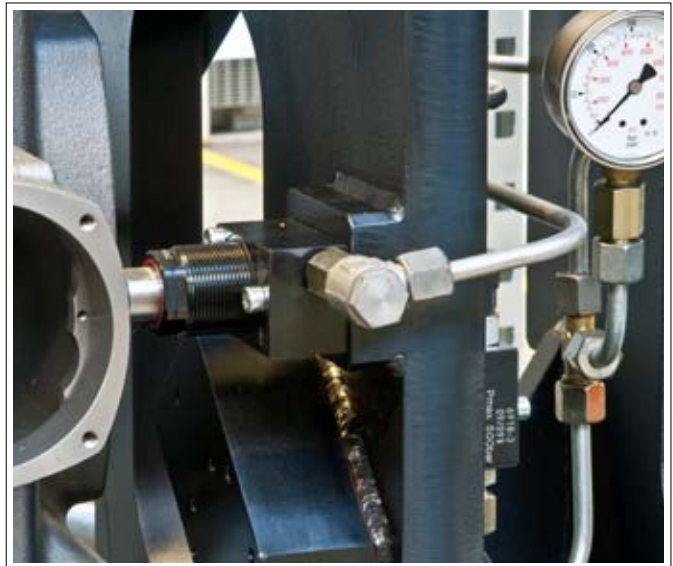

Subject to technical alterations.

No. 6965

Hydraulic Compensating Clamp

single-acting,
max. operating pressure 100 bar.

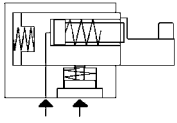

Order no.	Article no.	max. clamping force [kN]	max. locking force [kN]	Clamping stroke [mm]	Compensating stroke [mm]	Pin dia.	Weight [g]
320333	6965-08-00	2	1	12	3	16,0*	1675
320341	6965-08-01	2	1	12	3	5,5	1675
320358	6965-08-02	2	1	12	3	8,5	1675

Design:

Cylinder housing made of steel, blued. Piston is steel, hardened and ground. Complete with four mounting screws, M6 x 70, and O-rings for flange-sealing.

Application:

The Hydraulic Compensating Clamp is employed in fixtures for the distortion-free, floating clamping and support of workpieces. It is possible to use several Hydraulic Compensating Clamps without distorting a workpiece.

Features:

The floating support piston has a 3 mm compensating stroke, so that workpieces with substantial variations in form, or variable and imprecise hole tolerances can be clamped. Directly following the workpiece clamping operation, a sequential valve operates to lock the support piston in exactly the position it has adopted after clamping. The hydraulic supplies can be provided through ports with screwed connections in the clamp element, or directly through drillings in the fixture body. The workpiece support on the compensating clamp is easy to change, and these elements can, by providing suitably-formed supports, be quickly and simply adapted to different workpiece contours.

Note:

Please do not operate a Hydraulic Compensating Clamp without a workpiece in place; doing so can damage the return spring or cause it to set and lose force.

For single acting cylinders there is risk of sucking in coolant through the breather port. In such cases the breather port has to be piped to a clean protected area. The system has to be completely vented during installation.

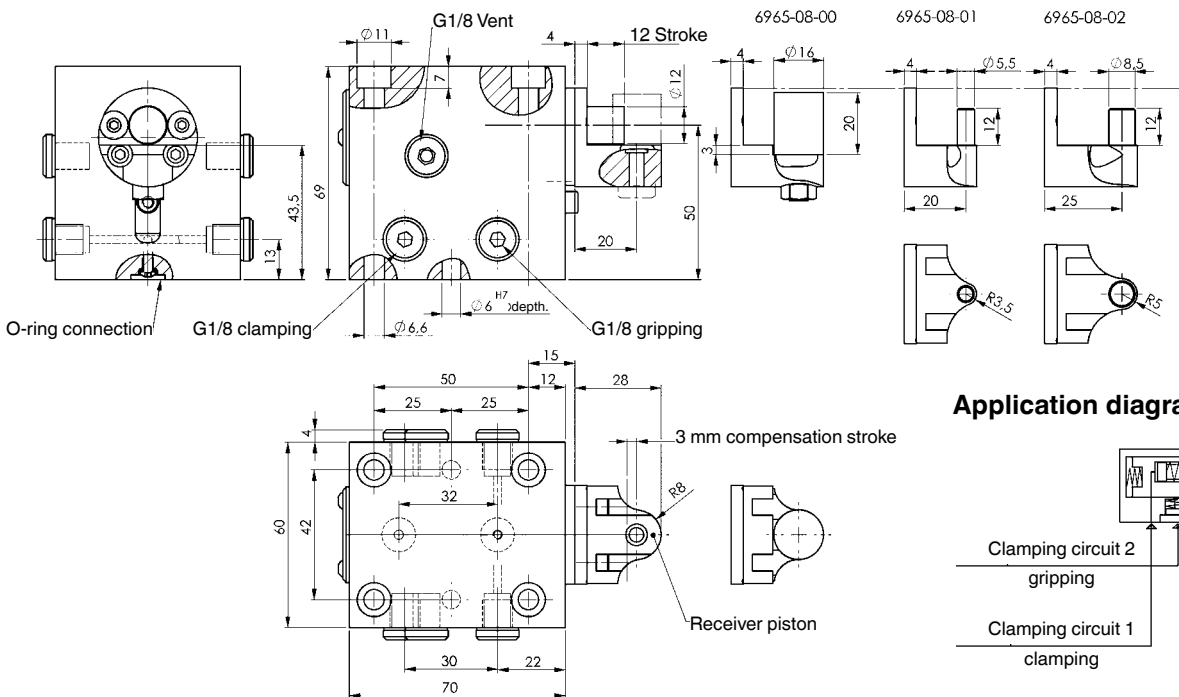

Application diagram:

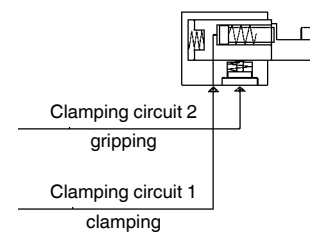

Note:

A delay of at least 2 sec. should be maintained between gripping and clamping.

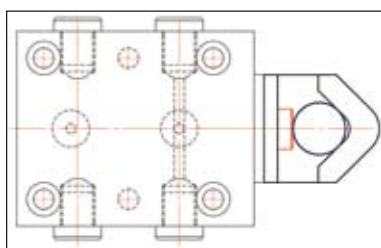

Clamping of workpiece with moulded lugs

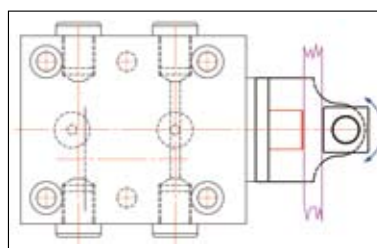

Clamping at heat fin

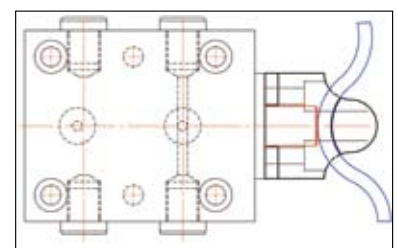

Clamping to CAD-data geometry



Hydraulic compensating clamp no. 6965 in unclamped (left) and clamped state (right).

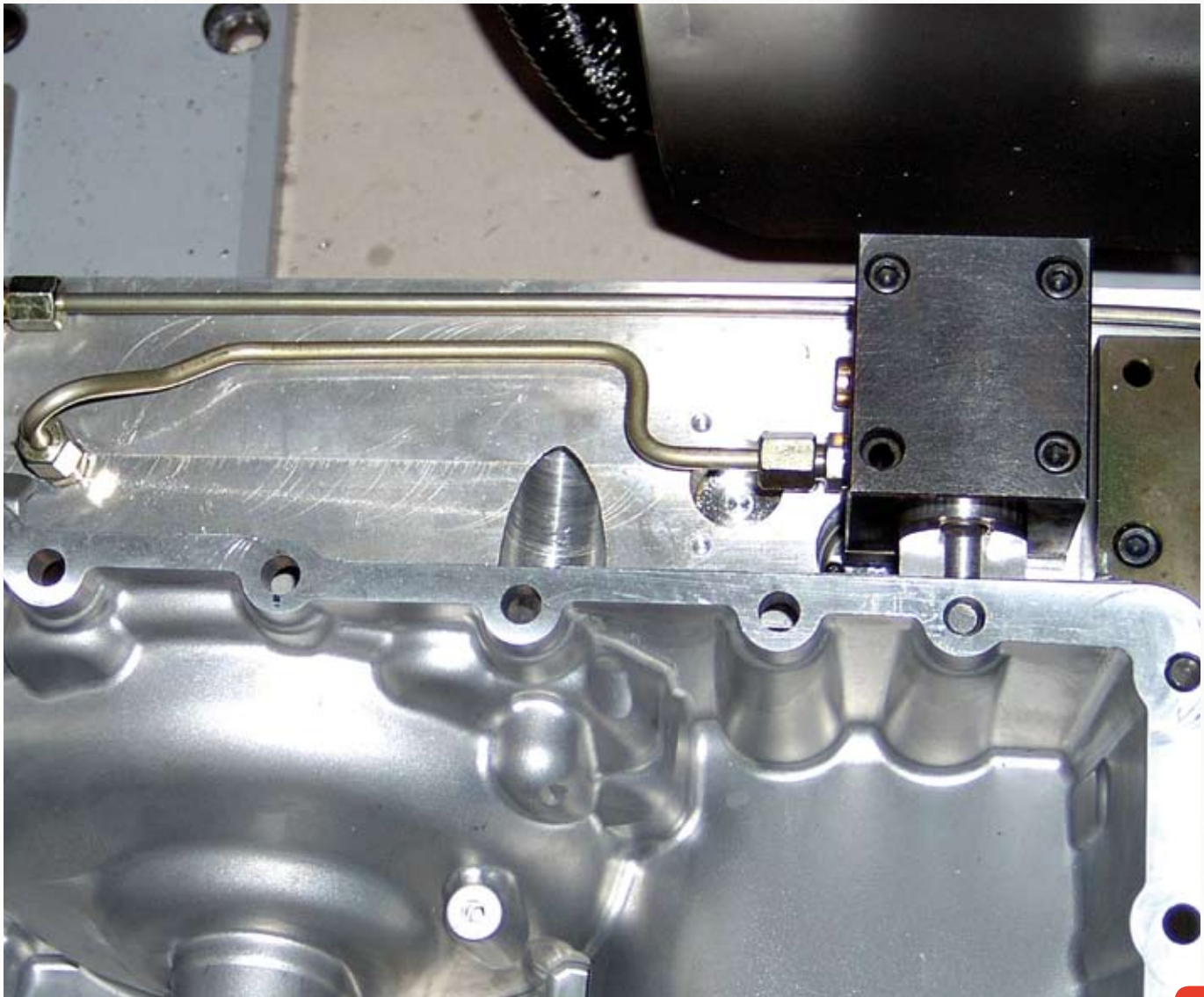

Subject to technical alterations.

LOW-PRESSURE CLAMPING TECHNOLOGY

- > clamping force up to 17 kN
- > operating pressure up to 70 bar
- > wipers to protect against contamination
- > oil supply via fixture body or threaded connection
- > single and double-acting variants

PRODUCT OVERVIEW:

Type	Clamping force / Supporting force [kN]	Stroke [mm]	No. of models	Operating mode
6941K	3,4 - 15,5	8,5 - 12,5	5	double-acting
6942K	2,6 - 17,0	-	5	double-acting
6944GH	2,0 - 3,5	6,5 - 8,0	3	single-acting

PRODUCT EXAMPLES:

NO. 6941K



> Clamping force: 3,4 - 15,5 kN

NO. 6942K



> Clamping force: 2,6 - 17,0 kN

NO. 6944GH



> Supporting force: 2,5 - 3,5 kN

No. 6949

Low pressure pump unit

with pressure limiting valve and pressure switch, dual acting, max. operating pressure 70 bar.



Order no.	Article no.	Clamping circuits	Flow rate [l/min.]	Valve type	Connection for remote control	No electrical controller	L x W x H	Weight [Kg]
326637	6949-61610	1	2,5	1x4/3	-	√	450 x 290 x 520	41
326652	6949-61614	1	2,5	1x4/3	√	-	450 x 410 x 550	49

Design:

Compact pump unit, 1 circuit, in two design versions. Both designs are complete with pressure relief valve, pressure switch, pressure gauge, 4/3-way valve, pressure accumulator.

Application:

These pump units are mainly used as drive elements for double-acting clamping devices.

Operation type:

Control panel with connection cable.

Features:

The gear pump is driven via an alternating current standard motor. Pressure is set via a pressure relief valve and a pressure switch. For proper functioning, the pressure relief valve should be set somewhat higher than the pressure switch.

Improved safety standard through the use of 4/3-way valves and unlockable twin check valve. No undesired movements in case of power failure.

The unit works in stand-by operation. In the event of a loss of pressure, the directional valve and the pump are automatically switched on by the pressure switch. When clamping, the switch-off signal comes from the pressure switch and when releasing from the time delay relay in the electrical control.

Note:

Ensure that the ventilation is working properly when connecting the elements. In the event of a loss of pressure, subsequent pumping must not exceed a maximum of 2 times per minute. The pump unit must not pump continuously.

Hydraulic diagram:

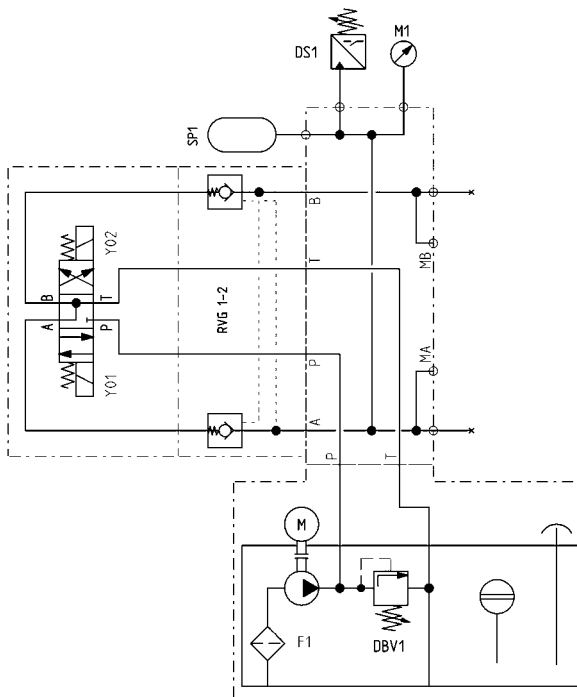

ZRP 2,5 : Q = 2,5 l/min., n = 1450 U/min.
Tank volume: V=10 l

Pump unit No. 6949

Hydraulic specifications:

Max. operating pressure	70 bar
Min. operating pressure	10 bar
Oil capacity, reservoir	6,6 litre
Oil capacity, usable	4 litre
Oil-flow rate	2,5 l/min.
Valve type	4/3 seat valve and 3/3 seat valve
No. of hydraulic circuits	1
Hydraulic connection	pipe fitting G1/4
Noise level	max. 75 dB(A)
Ambient temp. range	-10° C bis + 35° C
Position of use	upright
Pump type	Gear pump
Load cycle	max. 300/h
Hydraulic fluid	Hydraulic oil HLP and HLPD according to DIN 51524 Part 2
Oil recommendation	HLP 68 and HLPD 68
Viscosity	ISO VG 68 DIN 51519

Electrical specifications:

Nominal voltage	415 V/50 Hz three-phase
Control voltage	24 V DC
Valve voltage	24 V DC
Motor speed	1440 1/min.
Direction of rotation	clockwise
Motor rating	0,375 kW
Motor type	three-phase standard motor
Duty cycle	max. 50 % intermittent operation

Wiring circuit of pump unit with 2 clamping circuits, remote control

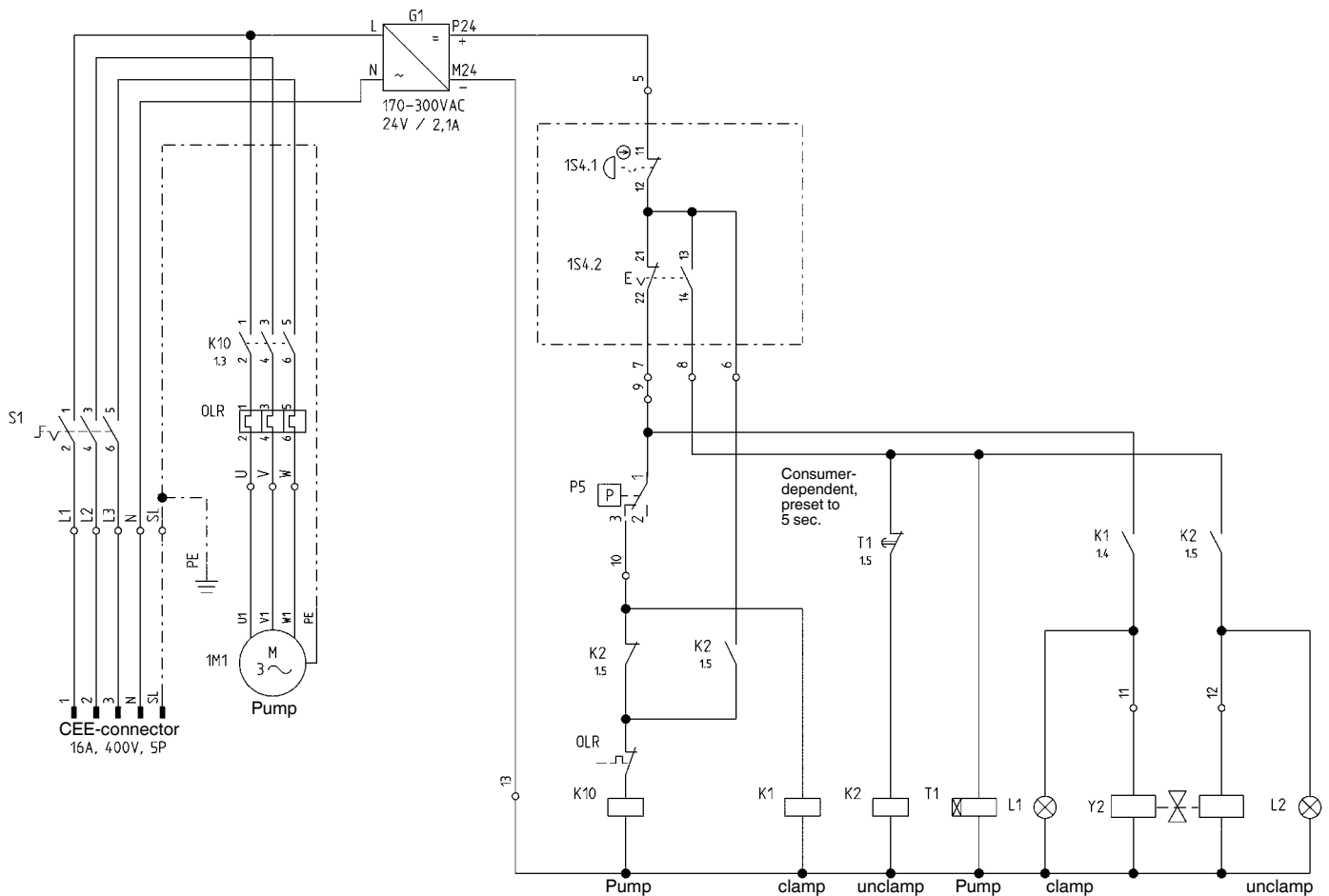

No. 6941K

Swing clamp

double acting,
max. operating pressure 70 bar,
min. operating pressure 15 bar.

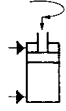

Order no.	Article no.	Clamping force at 70 bar* [kN]	effective piston area clamp [cm ²]	effective piston area unclamp [cm ²]	Clamping stroke [mm]	Total stroke [mm]	Oil capacity clamp [cm ³]	Oil capacity unclamp [cm ³]	Max. oil flow rate Q max. [l/min]	Weight [g]
326587	6341K-35-21	3,4	5,8	9,6	8,5	22	8,7	14,5	0,9	670
326603	6941K-35-22	3,4	5,8	9,6	8,5	22	8,7	14,5	0,9	670
326629	6941K-42-21	5,1	8,9	13,9	10,5	25	15,7	24,2	1,6	950
326645	6941K-42-22	5,1	8,9	13,9	10,5	25	15,7	24,2	1,6	950
326660	6941K-50-21	7,0	12,6	19,6	10,5	26	23,9	37,3	2,4	1400
326454	6941K-50-22	7,0	12,6	19,6	10,5	26	23,9	37,3	2,4	1400
326470	6941K-60-21	10,3	18,4	28,3	12,5	29	41,3	63,6	4,1	2100
326496	6941K-60-22	10,3	18,4	28,3	12,5	29	41,3	63,6	4,1	2100
326512	6941K-75-21	15,5	28,3	44,2	12,5	30	67,9	106,0	6,8	3350
326538	6941K-75-22	15,5	28,3	44,2	12,5	30	67,9	106,0	6,8	3350

* Clamping force and volume flow specification with clamp arm no. 6941S.

Design:

Cylinder housing is made of high-strength aluminium, red anodised. Piston rod case-hardened and chrome plated. Wiper on piston rod. Integrated, adjustable restrictor. Clamp arm not included.

Application:

The swing clamp is used particularly in fixtures in which the workpieces must be freely accessible and loaded from above. Workpieces with difficult shapes can also be clamped using special clamp arms (available on request).

Features:

Oil supply via threaded connection or oil channel in the fixture body. The swing motion employs a ball guide mechanism.

Note:

The swing clamps can be controlled via the pipe connections or via the channels on the front. In both cases, the existing O-rings must be used for sealing. A surface roughness of less than or equal to Rz 6.3 µm is necessary in the area of the O-rings for the flange surface on the customer's fixture.

The piston is guided, and so the max. permissible oil flow rate Q max. as well as the clamp arm length and weight must be observed. When mounting accessories at the piston, no force may be applied to the piston. When placing into operation, ensure that all air is bled from the system.

Attention: By the use of the adjustable restrictor please consider a possible pressure intensification!
Operating temperature: 0° - 70° C, Swivel angle: 90° ±3°, Repeatability of the clamping position: ±0,5°.

Dimensions table for flange plate

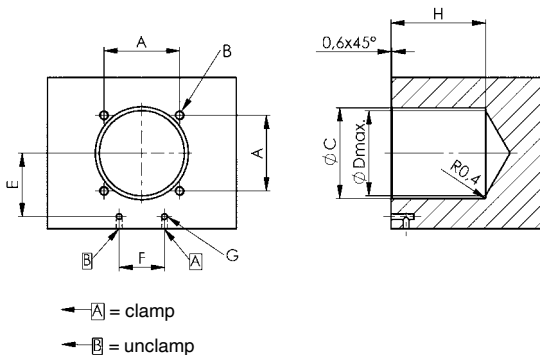

Article no.	A	B	C +0,3/0	D max.	E	F	G	H
6941K-35-21	40	M 5	48	45	30,0	22	3	53
6941K-35-22	40	M 5	48	45	30,0	22	3	53
6941K-42-21	47	M 6	55	50	33,5	24	3	60
6941K-42-22	47	M 6	55	50	33,5	24	3	60
6941K-50-21	55	M 6	65	60	39,5	30	5	64
6941K-50-22	55	M 6	65	60	39,5	30	5	64
6941K-60-21	63	M 8	75	70	45,0	32	5	72
6941K-60-22	63	M 8	75	70	45,0	32	5	72
6941K-75-21	75	M10	90	85	52,5	37	5	75
6941K-75-22	75	M10	90	85	52,5	37	5	75

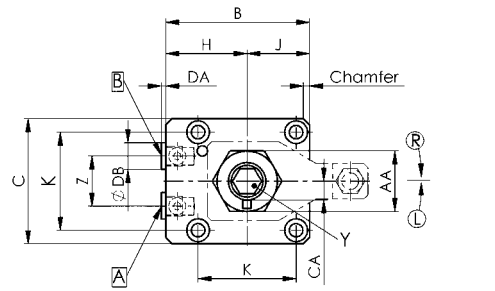

= clamp
 = unclamp

Code of types:

Type 21 = double-acting, right swinging
 Type 22 = double-acting, left swinging

Swing directions:

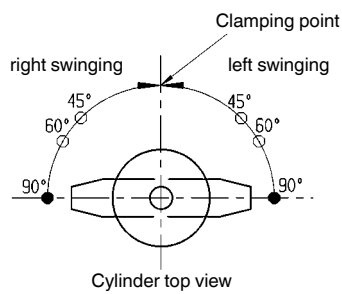

● = Standard type
 ○ = Special type

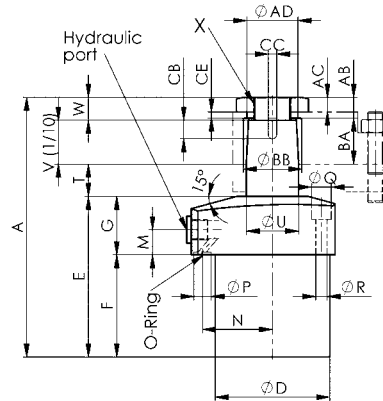

Dimensions

Order no.	Article no.	A	B	C	D -0,1/-0,2	E	F	G	H	J	K	M	N	P	Q	R	T	U	V	W	X	Y	Z
326587	6341K-35-21	134	61	51	48	80	52	28	35,5	25,5	40	13	30,0	3	9,5	5,5	30	22,0	14	11	M16x1,5	9x8	22
326603	6941K-35-22	134	61	51	48	80	52	28	35,5	25,5	40	13	30,0	3	9,5	5,5	30	22,0	14	11	M16x1,5	9x8	22
326629	6941K-42-21	146	69	60	55	87	59	28	39,0	30,0	47	12	33,5	3	11,0	6,8	27	25,0	20	12	M18x1,5	9x8	24
326645	6941K-42-22	146	69	60	55	87	59	28	39,0	30,0	47	12	33,5	3	11,0	6,8	27	25,0	20	12	M18x1,5	9x8	24
326660	6941K-50-21	153	81	70	65	93	63	30	46,0	35,0	55	13	39,5	5	11,0	6,8	28	30,0	20	12	M22x1,5	9x8	30
326454	6941K-50-22	153	81	70	65	93	63	30	46,0	35,0	55	13	39,5	5	11,0	6,8	28	30,0	20	12	M22x1,5	9x8	30
326470	6941K-60-21	179	92	80	75	108	71	37	52,0	40,0	63	16	45,0	5	14,0	9,0	31	35,5	26	14	M28x1,5	9x8	32
326496	6941K-60-22	179	92	80	75	108	71	37	52,0	40,0	63	16	45,0	5	14,0	9,0	31	35,5	26	14	M28x1,5	9x8	32
326512	6941K-75-21	192	107	95	90	114	74	40	59,5	47,5	75	16	52,5	5	17,5	11,0	32	45,0	32	14	M36x1,5	9x8	37
326538	6941K-75-22	192	107	95	90	114	74	40	59,5	47,5	75	16	52,5	5	17,5	11,0	32	45,0	32	14	M36x1,5	9x8	37

Order no.	Article no.	AA	AB	AC	AD	BA	BB H8	CA	CB	CC H8	CE	DA	DB	Chamfer	Hydraulic port	O-ring
326587	6341K-35-21	24	9	6	20,5	15	25	8	5,3	4	6,3	3,5	14	3x45°	G1/8	1BP5
326603	6941K-35-22	24	9	6	20,5	15	25	8	5,3	4	6,3	3,5	14	3x45°	G1/8	1BP5
326629	6941K-42-21	30	10	7	22,9	21	28	9	5,3	4	6,3	3,5	14	3x45°	G1/8	1BP5
326645	6941K-42-22	30	10	7	22,9	21	28	9	5,3	4	6,3	3,5	14	3x45°	G1/8	1BP5
326660	6941K-50-21	36	10	7	27,9	21	34	11	7,5	6	7,5	4,5	19	4x45°	G1/4	1BP7
326454	6941K-50-22	36	10	7	27,9	21	34	11	7,5	6	7,5	4,5	19	4x45°	G1/4	1BP7
326470	6941K-60-21	41	12	8	32,8	27	40	14	7,5	6	8,5	4,5	19	5x45°	G1/4	1BP7
326496	6941K-60-22	41	12	8	32,8	27	40	14	7,5	6	8,5	4,5	19	5x45°	G1/4	1BP7
326512	6941K-75-21	50	12	8	41,7	33	49	18	9,5	8	9,5	4,5	22	6x45°	G3/8	1BP7
326538	6941K-75-22	50	12	8	41,7	33	49	18	9,5	8	9,5	4,5	22	6x45°	G3/8	1BP7

No. 6941S Clamping arm

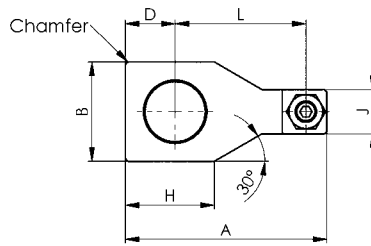
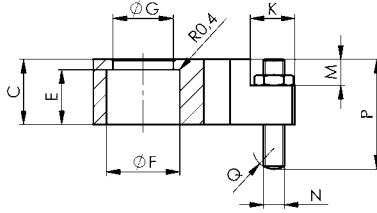

Dimensions

Order no.	Article no.	A	B	C	D	E ±0,1	F H8	G	H	J	K	L	M	N	P	Q	Chamfer
323345	6941S-35-65	65,5	35	19	17,5	15	25	20,6 +0,15	28	12	13	42,0	8	M6	38	10	1x45°
323360	6941S-42-77	77,0	38	25	19,0	21	28	23,0 +0,15	34	17	17	50,0	10	M8	42	15	1x45°
323386	6941S-50-91	91,5	50	25	25,0	21	34	28,0 +0,15	40	19	22	56,5	12	M10	47	20	3x45°
323402	6941S-60-105	105,0	58	32	29,0	27	40	32,9 +0,20	47	22	25	65,0	16	M12	52	30	4x45°
323428	6941S-75-127	127,0	75	38	38,0	33	49	41,8 +0,20	53	27	31	75,0	16	M16	56	45	10x45°

Order no.	Article no.	Clamping force at 70 bar [kN]	Weight [g]
323345	6941S-35-65	3,4	180
323360	6941S-42-77	5,1	310
323386	6941S-50-91	7,0	480
323402	6941S-60-105	10,3	810
323428	6941S-75-127	15,5	1500

Design:

Tempered and blued steel.

Application:

For Swing Clamp no. 6941K.

Note:

Clamping pressure, flow volume and clamp arm weight must be observed, see also installation notes at Swing Clamp no. 6941K.

On request:

Special designs available.

No. 6941R Clamping arm blank

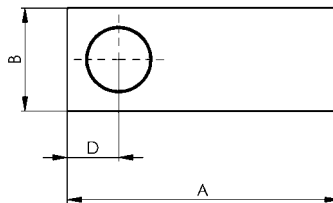
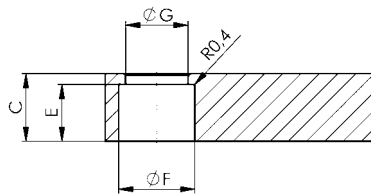

Dimensions

Order no.	Article no.	A	B	C	D	E ±0,1	F H8	G
323246	6941R-35-95	95	35	19	17,5	15	25	20,6 +0,15
323261	6941R-42-100	100	38	25	19,0	21	28	23,0 +0,15
323287	6941R-50-120	120	50	25	25,0	21	34	28,0 +0,15
323303	6941R-60-125	125	58	32	29,0	27	40	32,9 +0,20
323329	6941R-75-180	180	75	38	38,0	33	49	41,8 +0,20

Order no.	Article no.	Clamping force at 70 bar* [kN]	Weight [g]
323246	6941R-35-95	3,4	173
323261	6941R-42-100	5,1	304
323287	6941R-50-120	7,0	476
323303	6941R-60-125	10,3	805
323329	6941R-75-180	15,5	1443

* Clamping force and volume flow specification with clamp arm no. 6941S.

Design:

Steel.

Application:

For Swing Clamp no. 6941K.

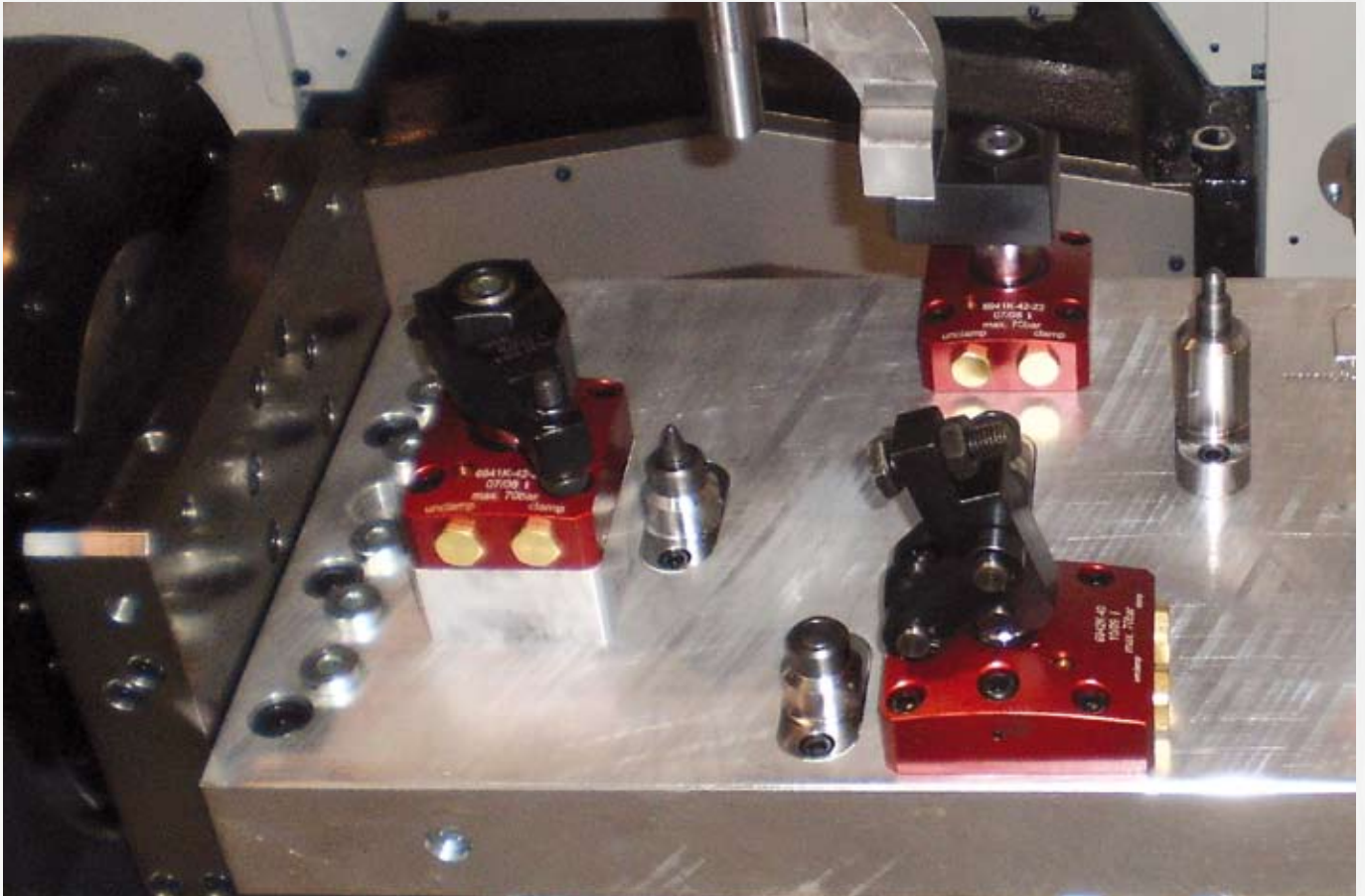

No. 6942K Link clamp

double acting,
max. operating pressure 70 bar,
min. operating pressure 15 bar.

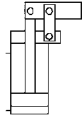

Order no.	Article no.	Clamping force at 70 bar* [kN]	Piston area [cm ²]	Stroke [mm]	Oil capacity [cm ³]	Weight [g]
322867	6942K-25	2,6	4,9	23,5	12,5	550
322883	6942K-32	3,6	8,0	26,0	20,9	800
322909	6942K-40	6,0	12,6	29,5	37,1	1250
322925	6942K-50	9,8	19,6	35,0	68,7	1950
322941	6942K-63	17,0	31,2	41,0	127,8	3300

* Clamping force specification with clamp arm no. 6942S.

Design:

Cylinder housing is made of high-strength aluminium, red anodised. Piston rod case-hardened and chrome plated. Wiper at piston rod. Pin made of tempering steel. Integrated, adjustable restrictor. Clamp arm not included.

Application:

The lever-type clamping fixture is used in clamping devices where workpieces must be freely accessible and are placed in from above. Particularly well suited for clamping in clamping pockets.

Features:

Head-flange version, hydraulic pressure supply through threaded ports on the rear side face, or through oil ports in the flat face with O-ring seals. Lever mechanism covers a range of 180°, moving 90° in each direction.

Note:

The link clamps can be controlled via the pipe connections or via the channels on the front. In both cases, the existing O-rings must be used for sealing. A surface roughness of less than or equal to Rz 6.3 µm is necessary in the area of the O-rings for the flange surface on the customer's fixture.

Piston force [kN] = piston area [cm²] x operating pressure [bar] / 100

Clamping force [kN] = piston area [cm²] x operating pressure [bar] x AA / BC [mm] x 100

Attention: By the use of the adjustable restrictor please consider a possible pressure intensification!

Operating temperature: 0° - 70° C,
3 Clamping positions: 0°, -90°, +90°.

On request:

Special designs available.

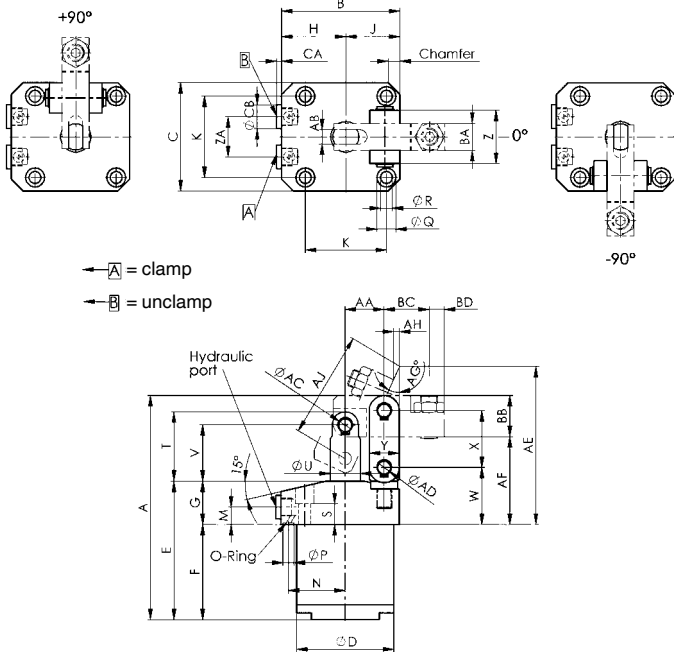

→ A = clamp
→ B = unclamp

Dimensions

Order no.	Article no.	A	B	C	D -0,1/-0,2	E	F	G	H	J	K	M	N	P	Q	R	T	U	V	W ±0,4	X	Y	Z	ZA
322867	6942K-25	114,0	61,0	51	48	75	47	28	35,5	25,5	40	12	30,0	3	9,5	5,5	35,0	14	29,0	34,5	26,0	13	21	22
322883	6942K-32	132,5	69,0	60	55	87	59	28	39,0	30,0	47	12	33,5	3	11,0	6,8	37,5	16	31,5	35,5	30,0	16	28	24
322909	6942K-40	147,0	81,0	70	65	93	63	30	46,0	35,0	55	13	39,3	5	11,0	6,8	45,0	18	37,0	39,0	35,5	19	37	30
322925	6942K-50	175,0	94,5	85	75	108	71	37	52,0	42,5	63	16	45,0	5	14,0	9,0	55,0	22	45,0	48,0	43,5	25	40	32
322941	6942K-63	207,0	109,5	100	90	128	88	40	59,5	50,0	75	16	52,5	5	17,5	11,0	64,5	28	52,0	52,5	52,5	28	49	37

Order no.	Article no.	AA	AB +0,1/0	AC H7	AD H7	AE	AF	AG	AH	AJ	BA	BB	BC	BD	CA	CB	Chamfer	Hydraulic port	o-ring
322867	6942K-25	18,5	6	6	6	92,4	51,0	18,9	4,3	61,2	12	16	23,5	6	3,5	14	3x45°	G1/8	1BP5
322883	6942K-32	21,0	8	6	8	101,9	53,5	19,9	4,7	71,7	16	20	29,0	8	3,5	14	3x45°	G1/8	1BP5
322909	6942K-40	24,5	10	8	10	111,4	59,0	20,5	4,3	78,7	19	25	32,0	10	4,5	19	4x45°	G1/4	1BP7
322925	6942K-50	30,0	11	10	12	130,8	72,0	21,4	4,5	90,8	22	32	37,5	11	4,5	19	10x45°	G1/4	1BP7
322941	6942K-63	36,0	13	12	15	146,5	81,0	22,4	5,0	104,6	25	38	41,5	14	4,5	22	11x45°	G3/8	1BP7

Subject to technical alterations.

Dimensions table for flange plate

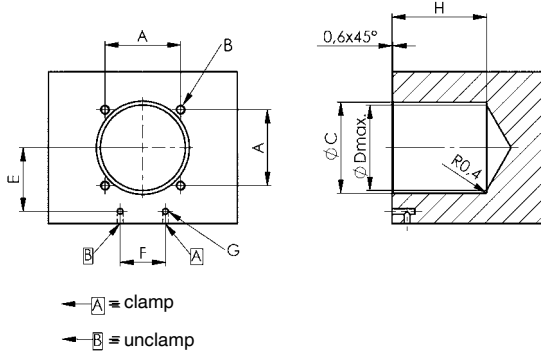

Article no.	A	B	C +0,3/0	D max.	E	F	G	H
6942K-25	40	M 5	48	45	30,0	22	3	48
6942K-32	47	M 6	55	50	33,5	24	3	60
6942K-40	55	M 6	65	60	39,5	30	5	64
6942K-50	63	M 8	75	70	45,0	32	5	72
6942K-63	75	M10	90	85	52,5	37	5	89

No. 6942S Clamping arm

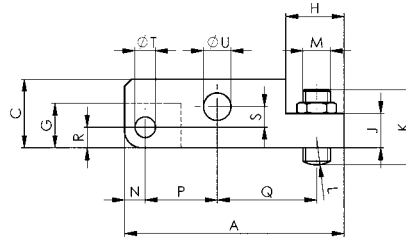
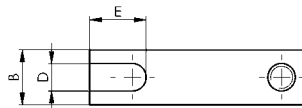

Order no.	Article no.	Clamping force at 70 bar [kN]	Weight [g]
323279	6942S-25-54	2,6	65
323295	6942S-32-64	3,6	130
323311	6942S-40-74	6,0	220
323337	6942S-50-88	9,8	380
323352	6942S-63-102	17,0	600

Design:

Tempered and blued steel.

Application:

For Link Clamp no. 6942K.

Note:

Clamping pressure, flow volume and clamp arm weight must be observed, see also installation notes at Link Clamp no. 6942K.

On request:

Special designs available.

Dimensions

Order no.	Article no.	A	B 0/-0,3	C	D +0,1/0	E	G	H	J	K	L	M	N	P	Q	R	S	T H7	U H7
323279	6942S-25-54	54,0	12	16	6	16,0	13,0	13	8	18	10	M6	6	18,5	23,5	6	3,5	6	6
323295	6942S-32-64	64,0	16	20	8	16,5	13,0	17	10	22	15	M8	6	21,0	29,0	6	6,0	6	6
323311	6942S-40-74	74,5	19	25	10	21,0	17,5	22	13	27	20	M10	8	24,5	32,0	8	7,5	8	10
323337	6942S-50-88	88,5	22	32	11	25,5	22,0	25	16	31	30	M12	10	30,0	37,5	10	9,5	10	12
323352	6942S-63-102	102,5	25	38	13	30,5	26,0	31	22	40	45	M16	11	36,0	41,5	11	13,0	12	15

No. 6942R Clamping arm blank

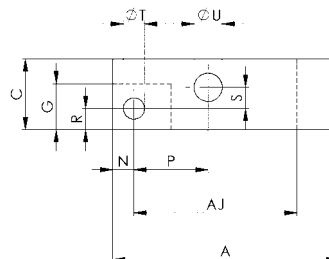
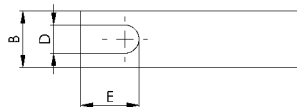

Order no.	Article no.	Clamping force at 70 bar* [kN]	Weight [g]
323170	6942R-25-85	2,6	61
323196	6942R-32-90	3,6	124
323212	6942R-40-105	6,0	207
323238	6942R-50-110	9,8	367
323253	6942R-63-180	17,0	575

* Clamping force specification with clamp arm no. 6942S.

Design:

Steel.

Application:

For Link Clamp no. 6942K.

Dimensions

Order no.	Article no.	A	B 0/-0,3	C	D +0,1/0	E	G	N	P	R	S	T H7	U H7
323170	6942R-25-85	85	12	16	6	16,0	13,0	6	18,5	6	3,5	6	6
323196	6942R-32-90	90	16	20	8	16,5	13,0	6	21,0	6	6,0	6	8
323212	6942R-40-105	105	19	25	10	21,0	17,5	8	24,5	8	7,5	8	10
323238	6942R-50-110	110	22	32	11	25,5	22,0	10	30,0	10	9,5	10	12
323253	6942R-63-180	160	25	38	13	30,5	26,0	11	36,0	11	13,0	12	15

No. 6962F/L

Support Element, cartridge type

Normally retracted. Hydraulic advanced.
Spring force for contact,
max. operating pressure 70 bar,
min. operating pressure 25 bar.

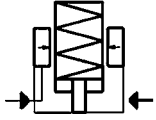

Order no.	Article no.	Contact force F1 [N]	Support force at 350 bar [kN]	Hub M [mm]	Tightening torque [Nm]	Vol. [cm³]	Weight [g]
326595	6944GH-2	6,0 - 8,8	2,0	6,5	31,5	0,6	200
325340	6944GH-3	7,8 - 9,8	3,0	8,0	50,0	0,9	250
325365	6944GH-4	15,6 - 18,6	3,5	8,0	63,0	1,3	350

Design:

Cylinder body made of tempered steel. Support plunger with internal thread. Wiper to protect against dirt and cutting fluid. Oil supply by manifold.

Application:

The support element is used as an extra support to prevent sagging and vibration of a workpiece.

Features:

Element with high load capacity and low height. Hydraulic and spring: the plunger is normally retracted. When pressure is applied, the support pin advances with a weak spring-applied force to contact the workpiece. The spring force varies with the stroke. As the hydraulic pressure rises, the support plunger is hydraulically clamped. When the pressure is released, the support plunger returns to the retracted position. Very high repeatability ensures optimum production quality.

Note:

Support plunger must be protected against the entry of dirt and cutting fluid by fitting a set screw or plug. When installing, ensure that all air is bled from the system. Insufficient ventilation will cause destruction of locking sleeve.

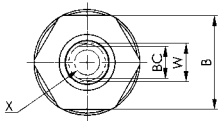
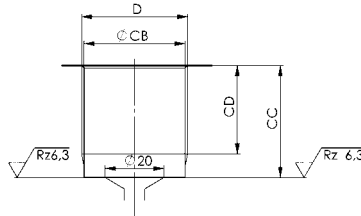
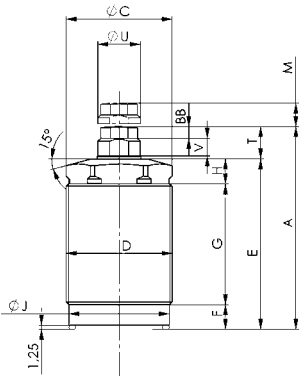

Dimensions

Order no.	Article no.	A	B	C	D	E	F	G	H	J	T	U	V	W	X	BB	BC	CB	CC	CD
326595	6944GH-2	66	24	26	M26x1,5	57	6,5	40	10,5	24,0	9	10	5	9,0	M6x12	4	9	24,3	20-30	CC-2
325340	6944GH-3	73	27	30	M30x1,5	62	9,5	42,3	10,2	28,2	11	10	7	9,0	M6x12	4	8	28,5	20-50	CC-9
325365	6944GH-4	69	32	36	M36x1,5	58	8,4	42,0	9,3	34,2	11	13	7	10,5	M8x11	4	11	34,5	20-48	CC-8

NO. 6917 / 6918
> Valves



NO. 6982
> Pressure switch



NO. 6991 / 6992
> Rotary coupling



NO. 6919-2
> Pallet decoupler block

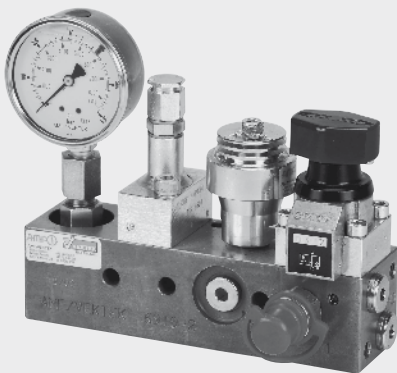

NO. 6919S
> Accumulator



NO. 6919-20 / 6919-25
> Pallet decoupler block unit/coupling unit



NO. 6985 / 6990
> High-pressure hoses and couplers



NO. 6988
> Manifolds



NO. 6983
> Pressure gauges



No. 6917-1 Pressure Reducing Valve

max. operating pressure 400 bar.



Order no.	Article no.	NG	Input pressure at P max. [bar]	Adjust. pressure at A min. [bar]	Adjust. pressure at A max. [bar]	Nominal flow [l/min]	Connection	Weight [g]
69179	6917-1	6	400	20	370	5	plate installation	1085

Design:

Cylinder body made of steel, phosphatized. Remaining parts made of tempering steel. Valve seat and piston are hardened and ground. This valve is leak free.

Application:

The stop valve shuts the flow from P to A when the pressure set A is reached. It opens when the pressure at A falls below the set value (e.g. through leakage).

1. Single-circuit system: The pressure reducing valve is used in a hydraulic circuit, where part of the cylinders are only to receive a reduced pressure (e.g. to prevent distortion of the workpieces or for positioning).

2. Dual-circuit system: If two working circuits are to be operated with different pressures from a single pump unit, the pressure of one circuit must be reduced by inserting a pressure reducing valve.

Symbols:

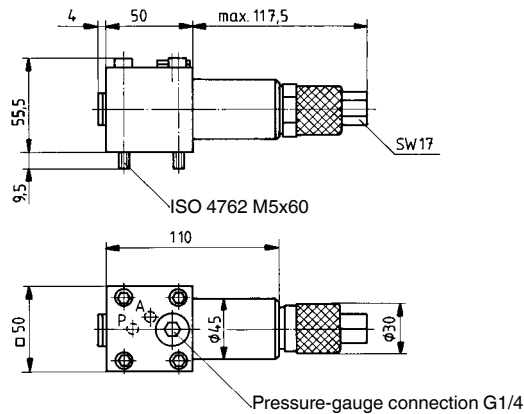
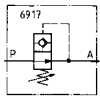

See hole pattern below

No. 6917A-1 Connecting Plate

for pressure reducing valve.



Order no.	Article no.	L x W x H	Connection	Weight [g]
69211	6917A-1	50 x 50 x 25	G1/4	450

Design:

Tempering steel, phosphatized.

Application:

For pipe connection of pressure reducing valve No. 6917-1.

Hole pattern shape A nominal size 6 according to DIN 24 340 T2; 11.82

As seen in direction of the plate.

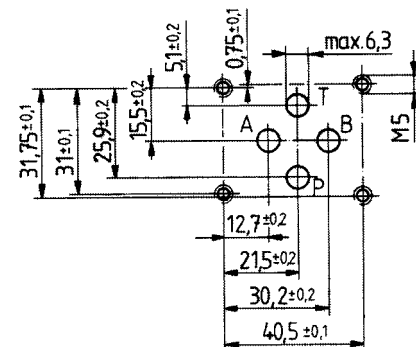
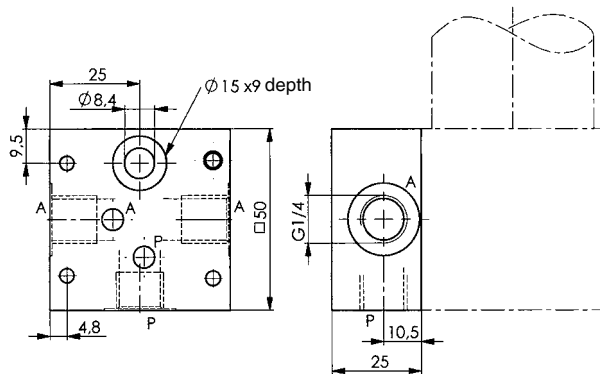

No. 6917R
Pressure control seat valve

for pipe fitting G1/4

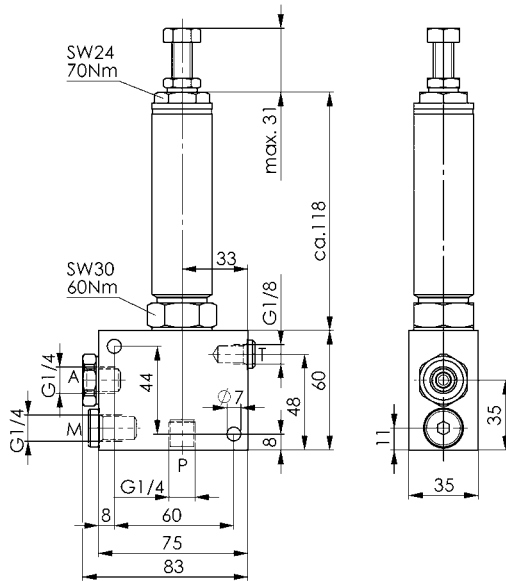
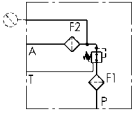
Threaded filter set spare parts

Order no.	Article no.	Nominal flow [l/min]	Min. operating pressure [bar]	Max. operating pressure [bar]	Weight [g]
326405	6917R-5-130	5	8	130	1860
326421	6917R-5-380	5	30	380	1860

Design:

Leak-oil-free 3-way pressure regulating valve as piping valve in seat design, directly actuated. With additional oversteer compensation (integrated pressure-limitation function). The valve mainly consists of three parts: the valve accommodating body with the P, T and A connections in G 1/4, the clamp-in valve with inlet filtering and the additional filter element in the A-channel.

P is the inlet and A is the outlet of the valve. T is the tank connection and must be discharged to the tank separately or in a common line.

Application:

The pressure regulating valve is normally open.

With changing, higher input pressure, it maintains the output pressure largely constant. As soon as the set pressure is reached at the consumer, the valve closes and is leak-proof.

If the pressure between the valve output and the consumer rises above the set overload value, the excess pressure is reduced over the third connection (T-connection).

The valve can be used in front of a directional control valve in the P-channel or behind a directional control valve in the A and/or B-channel.

Features:

The controlled pressure and overload pressure are set simultaneously with an adjusting screw. The overload pressure is always about 10 bar above the regulation pressure. Protection against outside force and puncturing of the valve. The valve flow regulates P to A. The inlet P and outlet A are each protected against coarse contamination by a filter element with the nominal filter mesh of 100 µm.

The pressure regulating function is avoided in the opposite direction (from A to P).

Pressure is adjusted with an adjusting screw.

To set and read the pressure, a pressure display device must be installed at the valve outlet. The pressure setting can be sealed.

Note:

Observe mounting instructions.

Order no.	Designation	Filteration [µm]	Weight [g]
326678	Filter cartridge	100	14

No. 6917F

Pressure control seat valve

for O-ring joint,

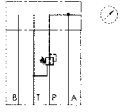

Order no.	Article no.	Nominal flow [l/min]	Min. operating pressure [bar]	Max. operating pressure [bar]	Weight [g]
326504	6917F-3-130	6	8	130	2100
326785	6917F-3-380	12	30	380	2100

Design:

Leak-oil-free 3-way pressure regulating valve as flange valve in seat design, directly actuated. With additional oversteer compensation (integrated pressure-limitation function). The valve mainly consists of three parts: the spacer plate with the standard hole pattern of NG 6, CETOP 3, the reversing plate and the clamp-in valve. The clamp-in valve is seated in the reversing plate in the P-channel. The oil flow is redirected from the valve inlet P1 to the valve outlet P2 in the reversing plate from P2 to A. The channels P, T and A must always be present on the opposite flange surface. The dimensions are recorded in the standards DIN 24340-Form A, CETOP R 35 H and ISO 4401.

Application:

The pressure regulating valve is normally open. With changing, higher input pressure, it maintains the output pressure largely constant. As soon as the set pressure is reached at the consumer, the valve closes and is sealed leak-proof. If the pressure between the valve output and the consumer rises above the set overload value, the excess pressure is reduced over the third connection (T-connection).

The valve can be used in front of a directional control valve in the P-channel or behind a directional control valve in the A and/or B-channel.

Features:

The controlled pressure and overload pressure are set simultaneously with an adjusting screw. The overload pressure is always about 10 bar above the regulation pressure.

Protection against outside force and puncturing of the valve.

The valve flow regulates P1 to P2.

The inlet P1 is protected against coarse contamination by a filter element with the nominal filter mesh of 100 µm.

In the opposite direction (from P2 to P1), the valve can be flowed through freely. To set and read the pressure, a pressure display device must be installed at the valve outlet.

Pressure is adjusted with an adjusting screw.

The pressure setting can be sealed.

Note:

Observe mounting instructions.

Replacement seal:

8 O-rings 9.25 x 1.78 – PU 90 Shore A, ident no. 493478

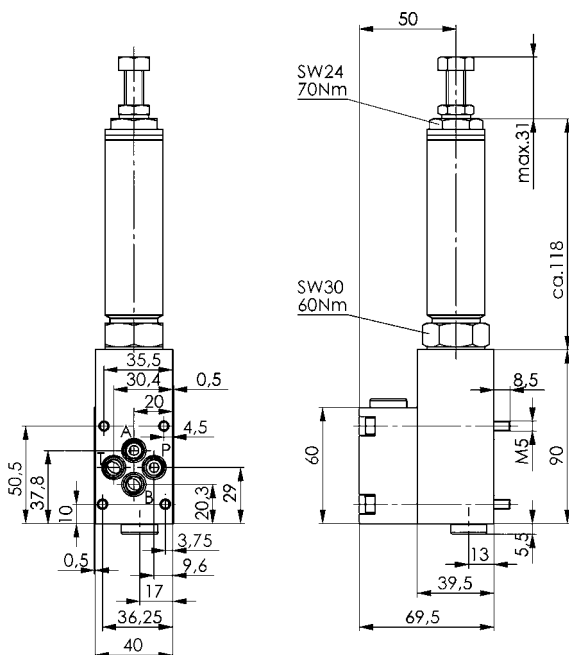

No. 6917E

Pressure control seat valve

for installation

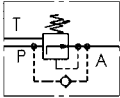

Order no.	Article no.	Nominal flow [l/min]	Min. operating pressure [bar]	Max. operating pressure [bar]	Weight [g]
492330	6917E-2-130	6	8	130	752
326462	6917E-3-130	6	8	130	780
326686	6917E-2-380	12	30	380	752
326488	6917E-3-380	12	30	380	780

Design:

Leak-oil-free 3-way pressure regulating valve as clamp-in valve in seat design, directly actuated. For the 3-way valve, with additional oversteer compensation (integrated pressure-limitation function). Screw-in thread M24 x 1.5.

Application:

The pressure regulating valve is normally open. With changing, higher input pressure, it maintains the output pressure largely constant. As soon as the set pressure is reached at the consumer, the valve closes and is sealed leak-proof. If the pressure between the valve output and the consumer rises above the set overload value, the excess pressure is reduced over the third connection (T-connection).

The valve can be used in front of a directional control valve in the P-channel or behind a directional control valve in the A and/or B-channel. The additional tank connection for the 3-way valve must always be planned.

Features:

For the 3-way valve, the controlled pressure and overload pressure are set simultaneously with an adjusting screw. The overload pressure is always about 10 bar above the regulation pressure. Protection against outside force and puncturing of the valve.

The valve flow regulates P to A.

The inlet P is protected against coarse contamination by a filter element with the nominal filter mesh of 100 µm.

In the opposite direction at the valve (from A to P), the valve can be flowed through freely.

To set and read the pressure, a pressure display device must be installed at the valve outlet.

Pressure is adjusted with an adjusting screw.

The pressure setting can be sealed.

Note:

Observe mounting instructions.

No. 6917E-2

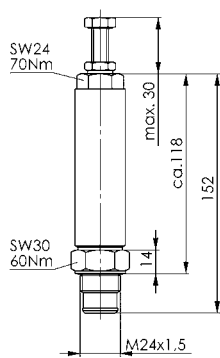
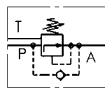

Mounting hole

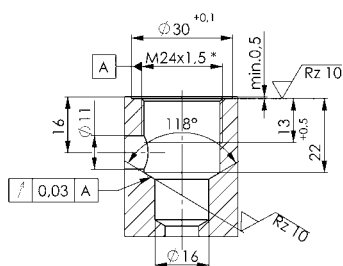

* Threaded countersink max. dia. 24

X (2 : 1)

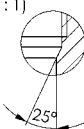

No. 6917E-3

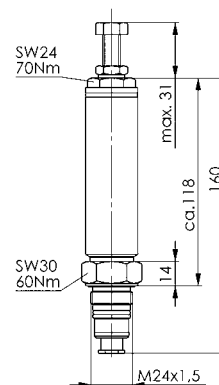
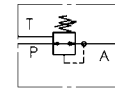

Mounting hole

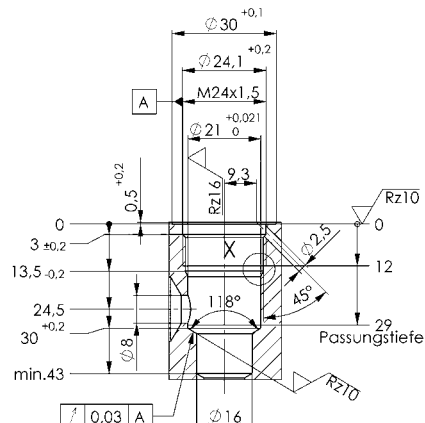

No. 6918 Sequence Valve

6918-6 for pipe fitting G1/4,
6918-11 for pipe fitting G1/4,
6918-2 for pipe fitting G1/4,
6918-3 for O-ring joint,
6918-4 fitting combination (pipe),
6918-5 fitting combination (pipe).



Order no.	Article no.	Min. operating pressure [bar]	Max. operating pressure [bar]	Nominal flow [l/min]	Viscosity [cSt]	Ambient temp. [°C]	Direction of flow	Possible statically overload	Weight [g]
325068	6918-6	8	80	40	10-500	-40 - +80	P-A	~1,5xp max.	750
326306	6918-11	16	160	40	10-500	-40 - +80	P-A	~1,5xp max.	750
60517	6918-2	50	500	40	10-500	-40 - +80	P-A	~1,5xp max.	750
66100	6918-3	50	500	40	10-500	-40 - +80	P-A	~1,5xp max.	750
320135	6918-4	50	500	40	10-500	-40 - +80	P-A	~1,5xp max.	750
320143	6918-5	50	500	40	10-500	-40 - +80	P-A	~1,5xp max.	750

Design:

Steel housing, nitrided. Sealing nut galvanized. All functional components hardened and ground. Balls out of roller bearing steel.

Application:

The pressure sequence valve is used where another hydraulic system or another consumer should be activated after achieving a specified pressure. If a circuit is designed with several sequence valves, it must be observed that the pressure in this circuit is always adjusted in the last respective pressure stage. The switching pressure for this type, irrespective of the pressure on the output side (consumer side) remains largely constant.

Note:

For disassembly of the pressure valve please release first SW (AF) 24, then SW 22. For assembly please use reverse sequence and observe max. seating torque. The pressure difference between P and A depends on the preload of the adjustment spring.

No. 6918-2 No. 6918-6 No. 6918-11

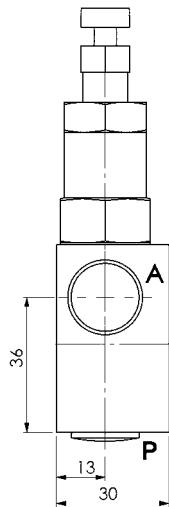
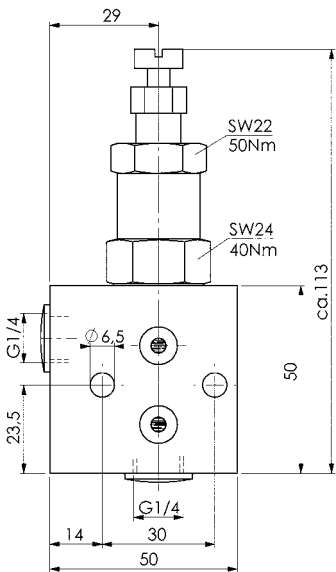
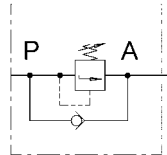

No. 6918-3

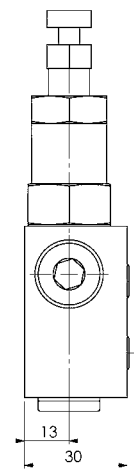
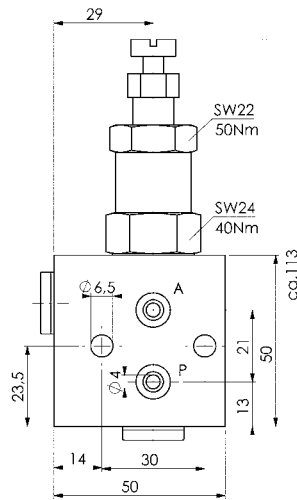
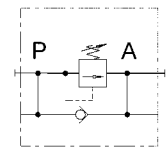

Application example

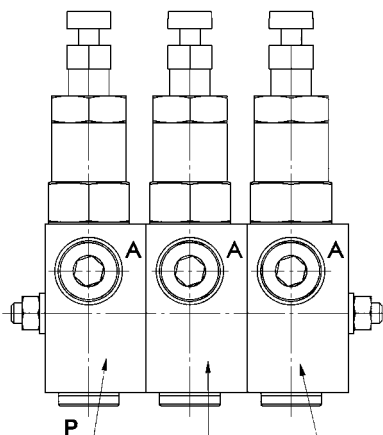

No. 6818-3 No. 6818-4 No. 6818-5
Order No. 66100 Order No. 320135 Order No. 320143

Application examples - Wiring diagram

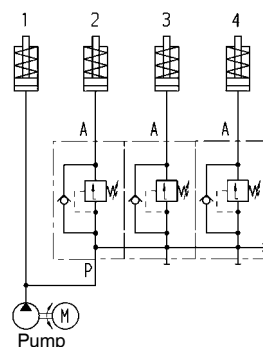

No. 6918

Sequence Valve

for installation



Order no.	Article no.	Min. operating pressure [bar]	Max. operating pressure [bar]	Nominal flow [l/min]	Viscosity [cSt]	Ambient temp. [°C]	Direction of flow	Possible statically overload	Weight [g]
320366	6918-2-02-02	50	500	40	10-500	-40 - +80	P-A	~1,5xp max.	150
408401	6918-2-02-03	8	80	40	10-500	-40 - +80	P-A	~1,5xp max.	150
325118	6918-2-02-04	16	160	40	10-500	-40 - +80	P-A	~1,5xp max.	150

Design:

Steel housing, nitrided. Sealing nut galvanized. All functional components hardened and ground. Balls out of roller bearing steel.

Application:

The pressure sequence valve is used where another hydraulic system or another consumer should be activated after achieving a specified pressure. If a circuit is designed with several sequence valves, it must be observed that the pressure in this circuit is always adhisted in the last respective pressure stage. The switching pressure for this type, irrespective of the pressure on the output side (consumer side) remains largely constant.

Note:

For disassembly of the pressure valve please release first SW (AF) 24, then SW 22. For assembly please use reverse sequence and observe max. seating torque. The pressure difference between P and A depends on the preload of the adjustment spring.

Mounting hole

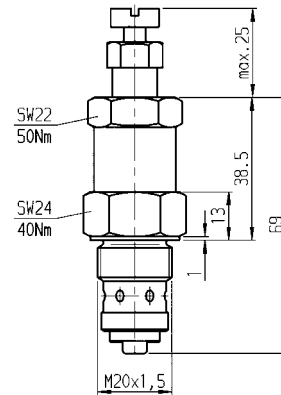
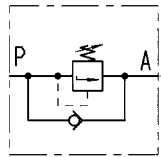
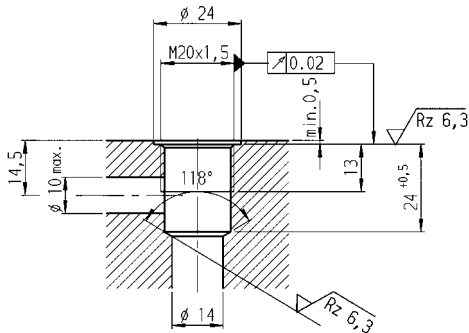

No. 6918-10

Pressure Relief Valve

for pipeline installation

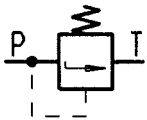

Order no.	Article no.	Min. operating pressure [bar]	Max. operating pressure [bar]	max. pressure in T [bar]	Nominal flow [l/min]	Ambient temp. [°C]	Viscosity [cSt]	Weight [g]
65375	6918-10	100	500	500	20	-40 - +80	10-500	200
288225	6918-10-001	30	160	20	20	-40 - +80	10-500	200

Design:

Nodular grey cast iron, body galvanized (6918-10-001) steel parts. Sealing of spindle is possible to ensure the set pressure.

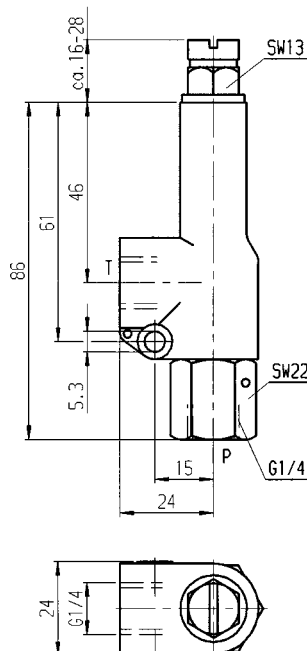
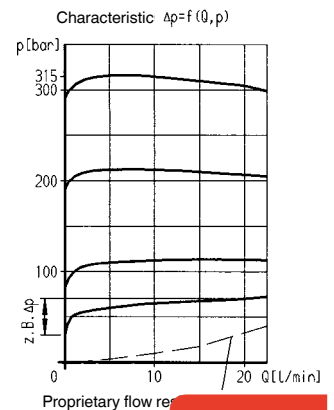

Diagram:



No. 6918

Sequence valve

for O-ring joint,
Pressure-time-delayed
max. operating pressure 250 bar.



Order no.	Article no.	Min. operating pressure [bar]	Max. operating pressure [bar]	Nominal flow [l/min]	Delay setting range [s]	Direction of flow	Weight [g]
326280	6918-80-10	30	250	8	1-10	P-A	1500

Design:

Flange valve with NG 6. Hole pattern not standard.
The valve mainly consists of the housing, hydraulic piston, opening valve, throttle screw for coarse adjustment and the throttle screw for fine adjustment.
Oil supply takes place through drilled channels in the clamping device.

Application:

With this sequence valve with timer, pressure-independent switching sequences with a defined adjustable delay within a circuit can be achieved.
Parallel connection or series connection of several „sequence valves with timer“ is possible.

Features:

The compact shape makes it easier to mount on the clamping device. The hydraulic piston actuates the opening valve. Setting depends on the viscosity of the hydraulic oil. Viscosity depends on the pressure and temperature. The setting is valid for an operating mode. Pay attention to the pressure drop when the valve is opened.

Note:

Observe mounting instructions with design notes for the fixture manufacturer.

Replacement seal:

2 O-rings 7x1.5 NBR – 88 Shore A, ID no. 161810

Symbol

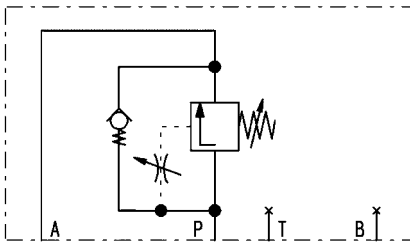

Application example

The workpiece is to be positioned in the fixture and clamped with hydraulic clamping cylinders

Clamping procedure

1. Cylinder 1 presses workpiece against stop a.
2. Valve opens A-line after the set time 1-10 sec.
3. Cylinder 2 and 3 run out with a time delay and press workpiece against stops b and c.

Wiring diagram

Sequential control as parallel circuit

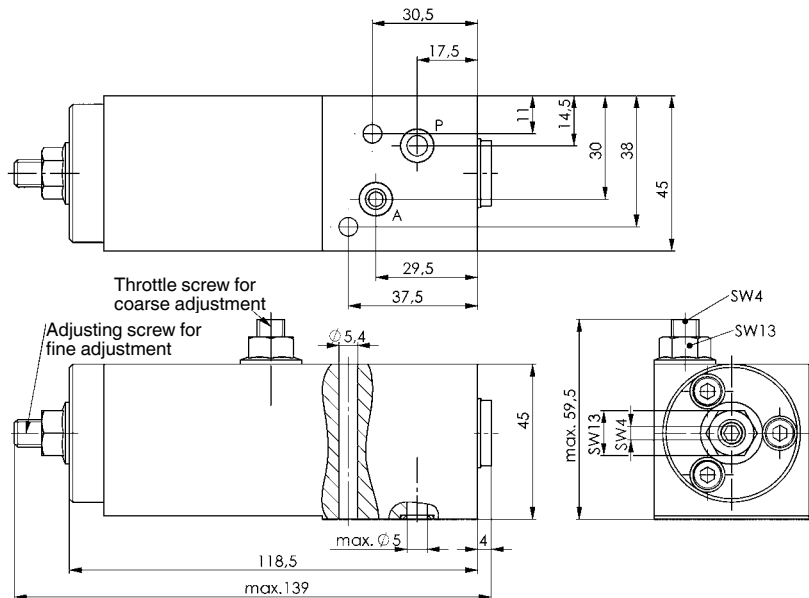
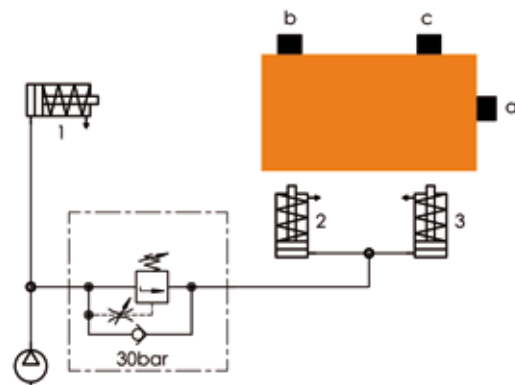

Wiring diagram

Sequential control as series circuit of 5 single-acting clamping cylinders

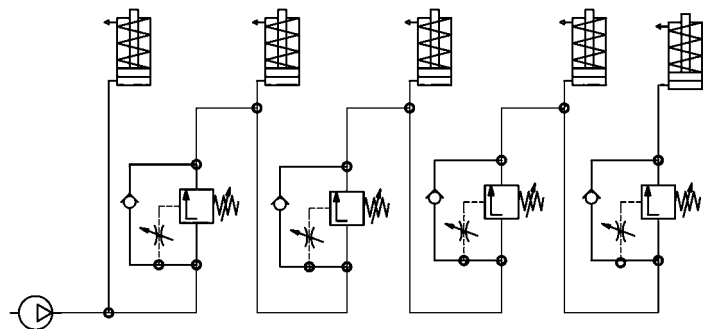

No. 6910-10/11

Manual Seat Valve, 2/2-Way and 3/2-Way

min. operating pressure 10 bar.



No. 6910-10

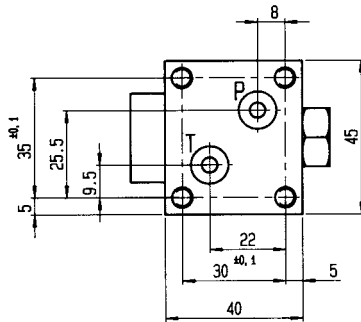

No. 6910-11

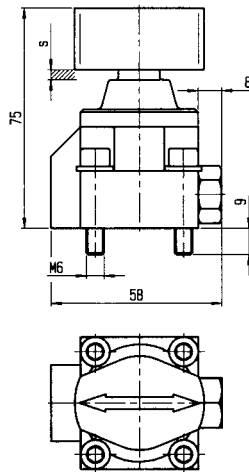
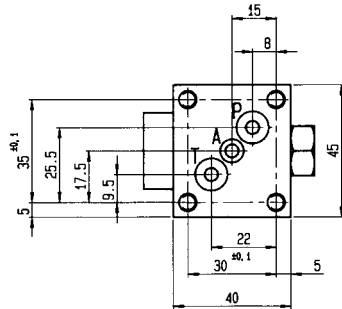

Order no.	Article no.	NG	Type	Connection	Max. operating pressure [bar]	Nominal flow [l/min]	Weight [g]
181214	6910-10	5	Seat valve	plate installation	500	12	400
114298	6910-11	5	Seat valve	Plate installation	500	12	400

Application:

By means of the 2/2 manual way seat valve an oil channel can be closed or opened. The 3/2 manual way seat valve allows to determine the direction of oil flow.

Features:

Hermetic sealing by ball seats. Sealing of the oil channels of the valve base with O-rings. The seat valve has completely hydraulic pressure compensation and negative switching.

Note:

The direction of flow has to be the direction of the arrow according to the symbol. The position of installation is optional. Hydraulic oil HLP or HLPD according to DIN 51524 Part 2.

Dimensions

Order no.	Article no.	Viscosity [cSt]	Ambient temp. [°C]	Actuation type	Switching torque [N cm]	Switching stroke [mm]	Switching angle
181214	6910-10	10-500	-40 - +80	Control knob	63	3,5	90°
114298	6910-11	10-500	-40 - +80	Control knob	63	3,5	90°

Symbol for: No. 6910-10

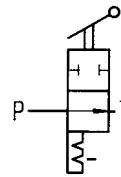

No. 6910-11

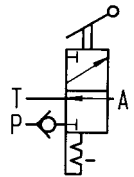

Diagram

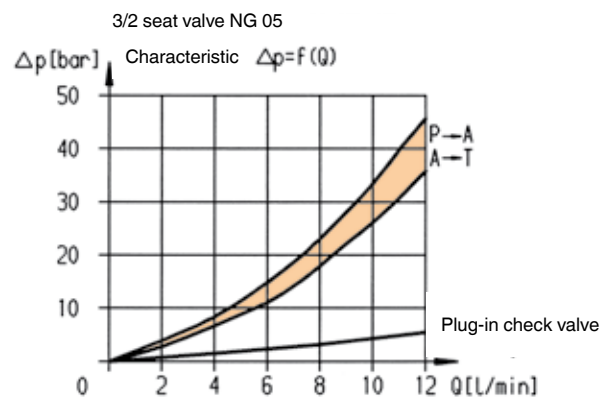

No. 6910A-05

Connection Plate

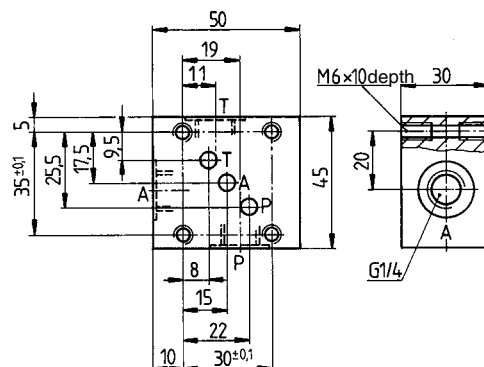

Order no.	Article no.	L x W x H	Connection	Weight [g]
60335	6910A-05	50x45x30	3 x G1/4	450

Design:

Tempering steel, TEM deburred and phosphatized.

Application:

For pipe connection in combination with
 - 3/2-way seat valve no. 6910-06-01
 - 2/2-way manual seat valve no. 6910-10
 - 3/2-way manual seat valve no. 6910-11.

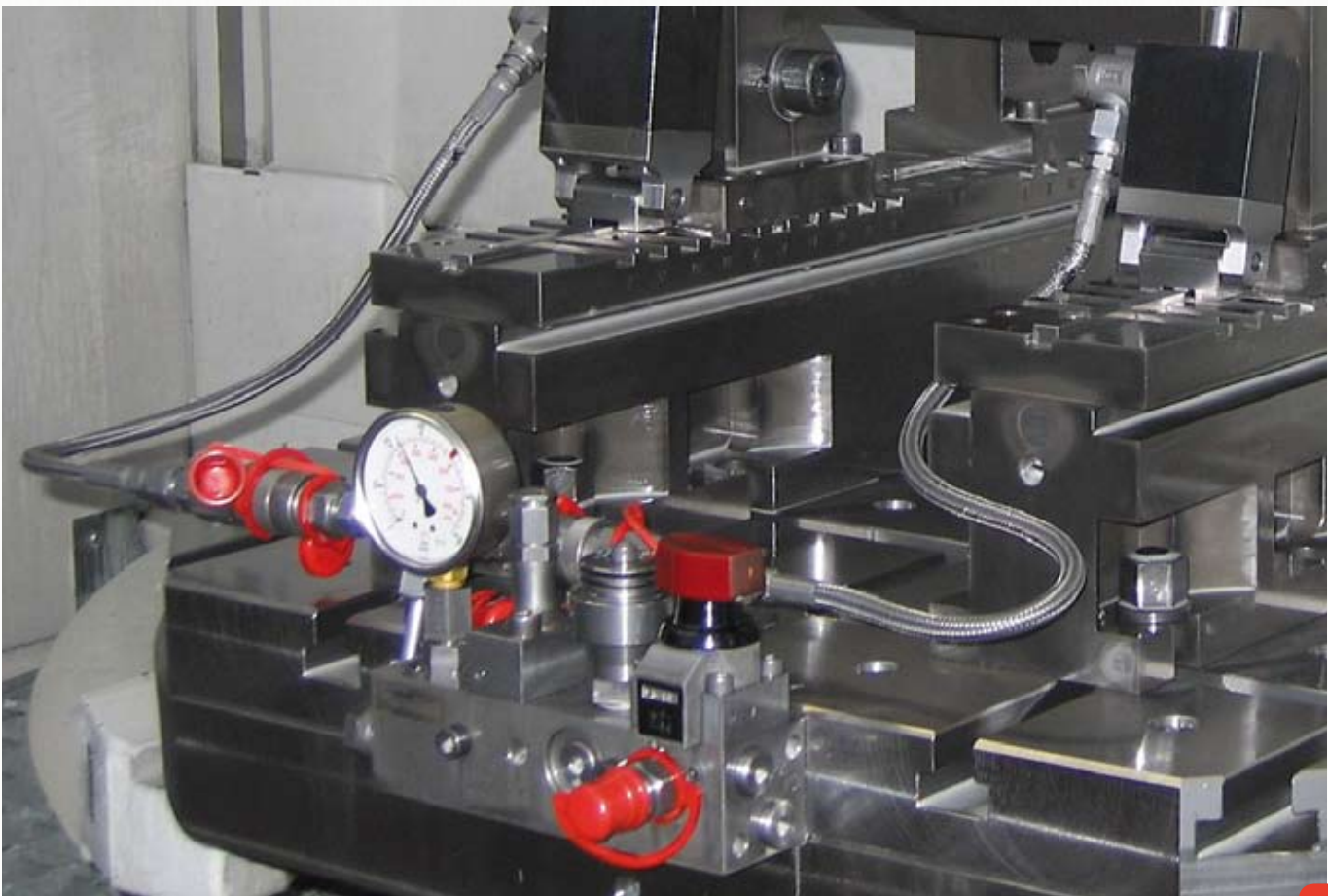

Subject to technical alterations.

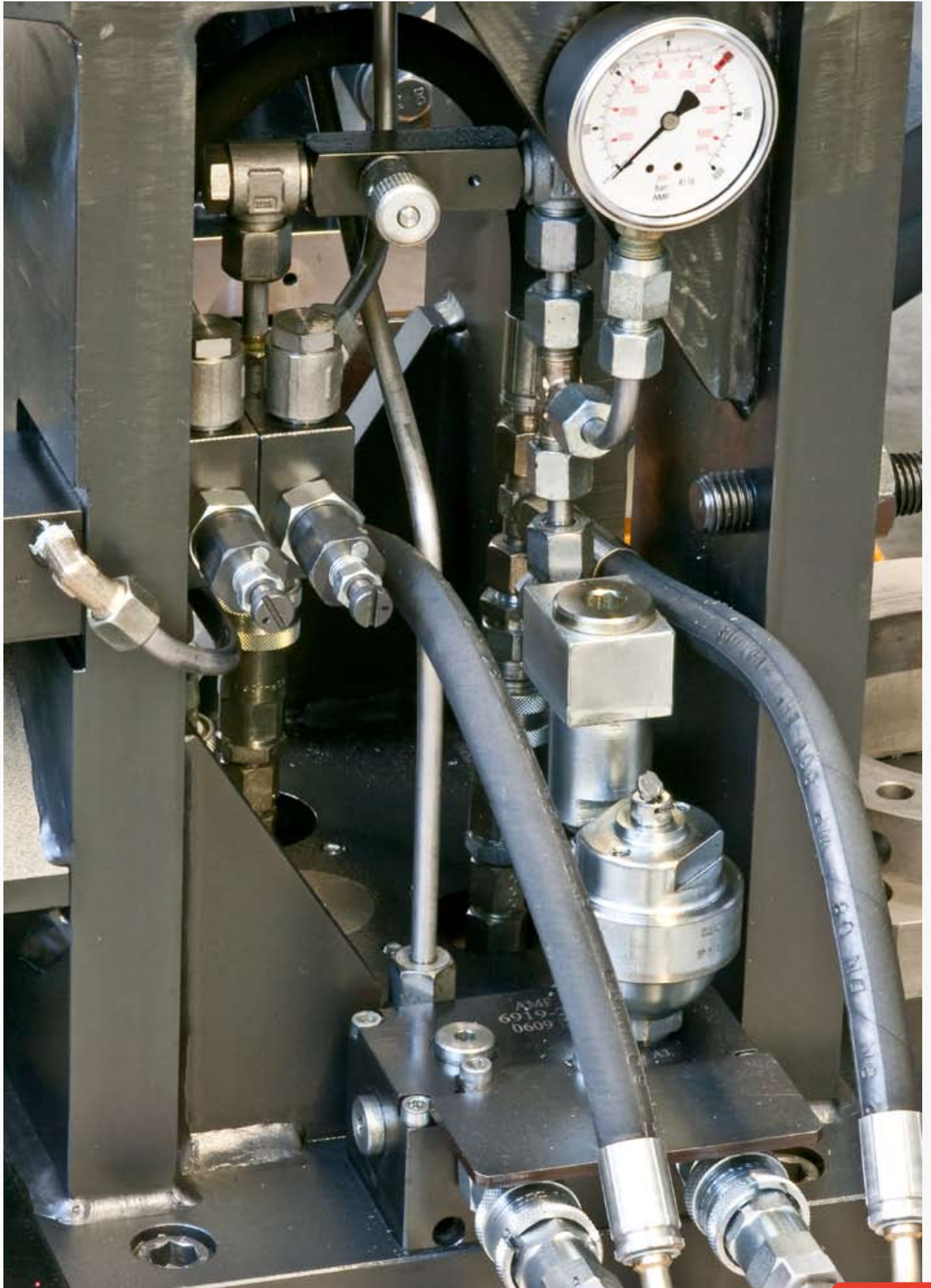

No. 6910-06-01/02

Seat Valve, 3/2-Way

max. operating pressure 500 bar,
min. operating pressure 10 bar.

Order no.	Article no.	NG	Type	Connection	Max. operating pressure [bar]	Nominal flow [l/min]	Viscosity [cSt]	Weight [g]
259168	6910-06-01	5	Seat valve	plate installation	500	12	10-500	710
259226	6910-06-02	5	Seat valve	plate installation	500	12	10-500	710

Design:

The ball, being the essential control element, is pressed either by a solenoid or a spring onto the hardened ball seats. The blocked flow direction is thus hermetically shut off. The solenoids work with or without a shift lever and are designed and checked to VDE 0580. The seat valve has a manual emergency actuator. A check valve is incorporated in channel P.

Application:

The 3/2-way seat valve is used to determine the direction of oil flow. These valves are mainly used for direct control of single-acting cylinders.

Features:

Hermetic sealing by ball seats. Sealing of the oil channels of the valve base with O-rings. The seat valve has completely hydraulic pressure compensation and negative switching.

Note:

The direction of flow must be the direction of the arrow according to the symbol. The position of installation is optional. Hydraulic oil HLP or HLPD according to DIN 51524 Part 2.

On request:

Seat valves with control voltage $U_{st} = 230 V\sim$ on request.

Dimensions

Order no.	Article no.	Ambient temp. [°C]	U _{st} [VA]	P [VA]	Switching time [ms]	Ed [%]	Switching frequency per hour	Code class
259168	6910-06-01	-40 - +80	24 =	20	100 on 50 off	100 (to 35°C)	2000	IP 54
259226	6910-06-02	-40 - +80	24 =	20	100 on 50 off	100 (to 35°C)	2000	IP 54

Symbol für

No. 6910-06-01

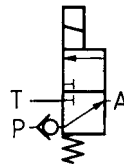

No. 6910-06-02

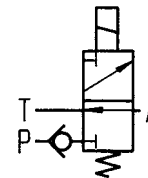

Diagram

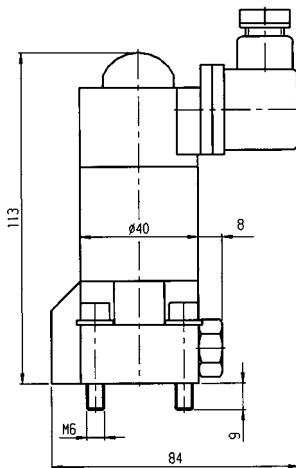
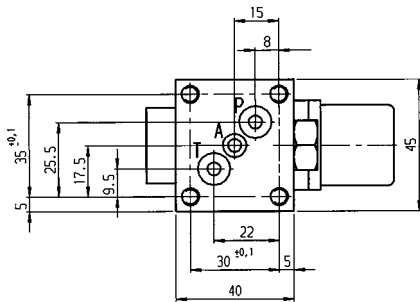
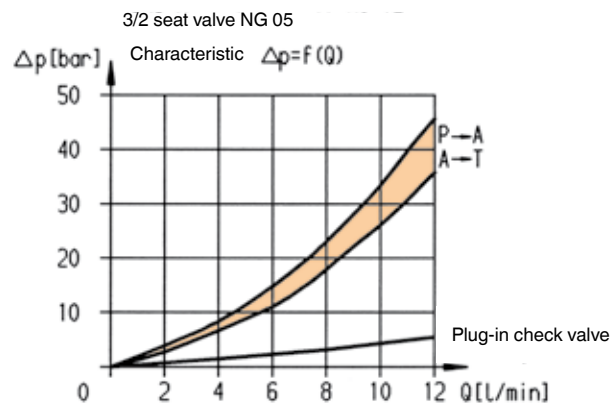

Dimensions apply to both sizes

No. 6910-06-04/05

Seat Valve, 3/2-Way

max. operating pressure 450 bar,
min. operating pressure 10 bar.

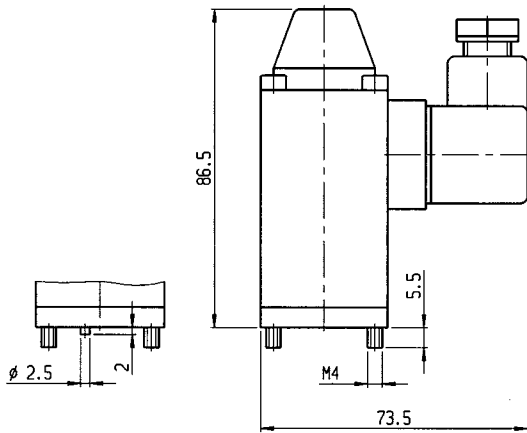
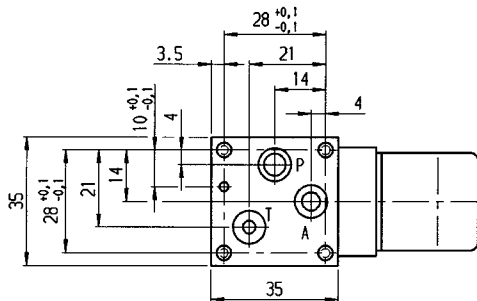

Dimensions apply to both sizes

Order no.	Article no.	NG	Type	Connection	Max. operating pressure [bar]	Nominal flow [l/min]	Viscosity [cSt]	Weight [g]
276824	6910-06-04	4	Seat valve	plate installation	450	8	10-200	600
65391	6910-06-05	4	Seat valve	plate installation	450	8	10-200	600

Design:

The ball, being the essential control element, is pressed either by a magnet or a spring onto the hardened ball seats. The blocked flow direction is thus hermetically shut off. The magnets work with or without a shift lever and are designed and checked to VDE 0580. The seat valve has a manual emergency actuator. A check valve is incorporated in channel P.

Application:

The 3/2-way seat valve is used to determine the direction of oil flow. These valves are mainly used for direct control of single-acting cylinders.

Features:

Hermetic sealing by ball seats. Sealing of the oil channels of the valve base with O-rings. The seat valve has completely hydraulic pressure compensation and negative switching.

Note:

The direction of flow must be the direction of the arrow according to the symbol. The position of installation is optional. Hydraulic oil HLP or HLPD according to DIN 51524 Part 2.

On request:

Seat valves with control voltage $U_{st} = 230\text{ V}\sim$ on request.

Dimensions

Order no.	Article no.	Ambient temp. [°C]	U_{st} [VA]	P [VA]	Switching time [ms]	Ed [%]	Switching frequency per hour	Code class
276824	6910-06-04	-40 - +80	24 =	24	70 on 50 off	100 (to 40°C)	2000	IP 65
65391	6910-06-05	-40 - +80	24 =	24	70 on 50 off	100 (to 40°C)	2000	IP 65

Symbol for

No. 6910-06-04

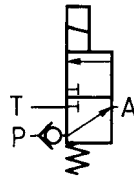

No. 6910-06-05

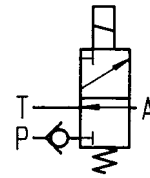

Diagram

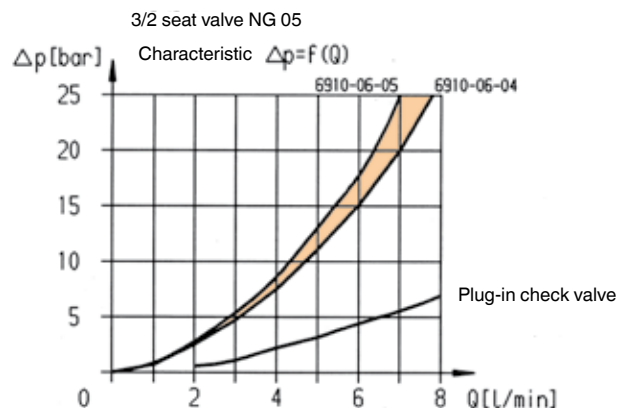

No. 6910A-07-02

Seat valve 3/3

max. operating pressure 400 bar,
min. operating pressure 10 bar.

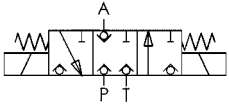

No. 6911A-07-01

Seat valve 4/3

max. operating pressure 400 bar,
min. operating pressure 10 bar.

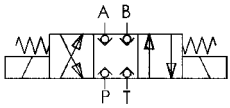

Order no.	Article no.	NG	Type	Connection	max. operating pressure [bar]	Nominal flow [l/min]	Viscosity [cSt]	Weight [g]
322073	6910A-07-02	6	Seat valve	plate installation.	400	20	10-500	2356

Order no.	Article no.	Ambient temp. [°C]	Ust [VA]	P [VA]	Switching time [ms]	Ed [%]	Switching frequency per hour	Code class
322073	6910A-07-02	-40 - +80	24V =	27,6	100 on, 50 off	100 (-35°C)	2000	IP67

Order no.	Article no.	NG	Type	Connection	max. operating pressure [bar]	Nominal flow [l/min]	Viscosity [cSt]	Weight [g]
322065	6911A-07-01	6	Seat valve	plate installation.	400	20	10-500	2356

Order no.	Article no.	Ambient temp. [°C]	Ust [VA]	P [VA]	Switching time [ms]	Ed [%]	Switching frequency per hour	Code class
322065	6911A-07-01	-40 - +80	24V =	27,6	100 on, 50 off	100 (-35°C)	2000	IP67

Design:

Oil-leak-free, sealed directional seat valves with standard mounting face NG 6. The hole pattern is standardised at the national, European and international levels. The dimensions are recorded in the standards DIN 24340-Form A, CETOP R 35 H and ISO 4401. The valves are actuated electromagnetically. The device socket as per DIN / EN 175301-803 is included in the scope of delivery.

Application:

The 3/3 and 4/3 directional seat valves determine the direction of oil flow. These valves are mainly used for direct control of single-acting and double-acting consumers. Suitable for pump units no. 6906.

Features:

With electrically current-free magnets, the valves take the closed neutral position. All connections are hermetically sealed due to the seat design. If both magnets are energised simultaneously, this creates a fourth switch position in which all connections are connected to the tank line and are thus pressure-free. In this switch position, the consumer lines can be easily coupled. A ball check valve is also inserted in the P-channel. This check valve prevents an undesired pressure compensation in the case of circuit overlaps. The seal between the valves and the counter-flange surfaces is made with O rings.

Note:

The valves can be supplied with 230 V AC 50/60 Hz control voltage on request.

Replacement seal:

4 O-rings 9.25x1.78 – PU 93 Shore A, order no. 493478

Replacement part:

Insert check valve, order no. 402156

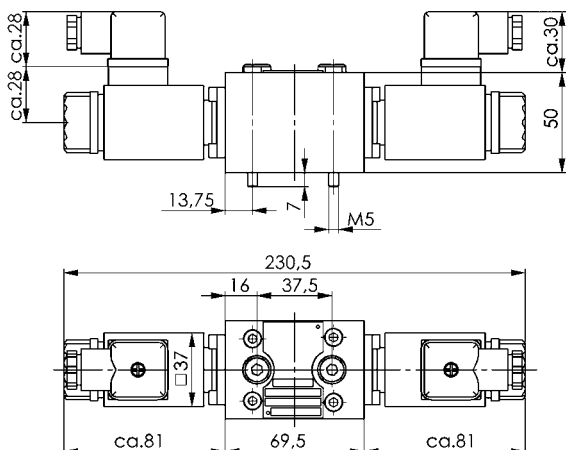
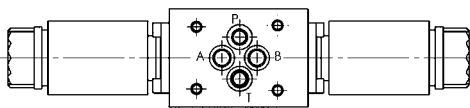

Hole pattern shape A nominal size 6 according to DIN 24 340

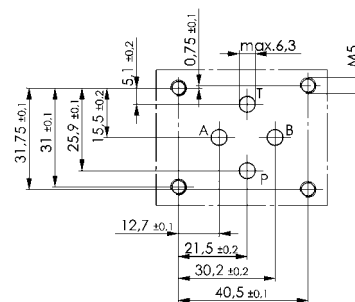

As seen in direction of the plate.

Nr. 6982E
Electronic pressure switch

Order no.	Article no.	Measurement range [bar]	Switch-point [bar]	Hysteresis [bar]	Operating temperature	Tightening torque [Nm]	Switching cycles	Weight [g]
326447	6982E-01	0-600	9-600	3-594	-25 - +80	20	≥100 millions	120

Design:

Compact electronic pressure switch with integrated 4-digit digital display for pressure measurement in the high-pressure range. Stainless steel measuring cell with thin-film strain gauge. Screw-in thread G $\frac{1}{4}$ A – DIN 3852-E, 2 switch outputs.

With 4-pin round connector M12 x 1 including supply line with free line end.

Application:

For the electronic-hydraulic pressure monitoring in pump units and in circuits of hydraulic clamping devices.

Features:

Display rotatable in two axes. As a result, the device can be oriented optimally in almost every mounting position. The four-digit digital display can depict the pressure in bar, psi or MPa. The switching direction is preset to opener function (off). The measured hydraulic actual pressure = upper switchpoint + takeover hysteresis is taken over with the mode button on the electronic pressure switch. The takeover hysteresis is 4% above the upper switching point. The back switchpoint 1 is determined through hysteresis 1 and is 8% below the upper switchpoint. The back switchpoint 2 is determined through hysteresis 2 and is 5% below back switchpoint 1. Back switchpoint 2 serves a warning function. All hysteresis values are permanently programmed. At the upper switchpoint, the signal for switching off the pump unit is preset to a delay of 1 second.

On request:

Available with 5-pin round connector on request. Analogue output signal 4-20 mA or 0-10 V available on request. The cable at the plug must then be shielded.

Dimensions

Order no.	Article no.	Power supply voltage [V]	PNP-output switching current [A]	Reaction time [ms]	Reproducibility [%]	Accuracy as per DIN 16086 [%]	Signal [V]	Code class
326447	6982E-01	18-35	1,2	10	±0,25 FS max.	±0,5 FS typ.	0-10	IP65

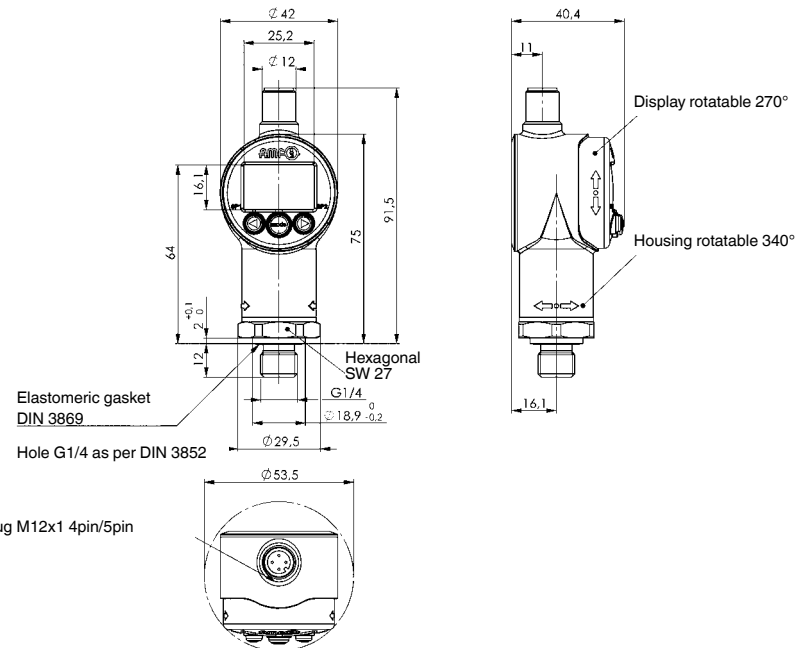

Device plug M12x1 4pin/5pin

Nr. 6982E-01-L
Round connector

Order no.	Article no.	Thread	Number of poles	Line length [m]
498709	6982E-01-L	M12x1	4	1,5

No. 6982-02

Piston Pressure Switch

electric-hydraulic

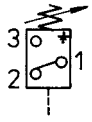

Order no.	Article no.	Operating pressure [bar]	Temp. [°C]	Mounting position	Code class	Weight [g]
176040	6982-04	10-100	-20 - +80	any	IP65	330
176214	6982-02	40-450	-20 - +80	any	IP 65	330

Application:

For electric-hydraulic pressure monitoring of a clamping circuit. The piston pressure switch can be mounted onto an adapter plate for tube connection.

Note:

Spare O-ring 4.47 x 1.78

Dimensions

Order no.	Article no.	Switch type	Switching frequency [1/min]	Voltage	Type
176040	6982-04	microswitch	100	30V - 250V = 5A	spring-loaded piston
176214	6982-02	microswitch	100		

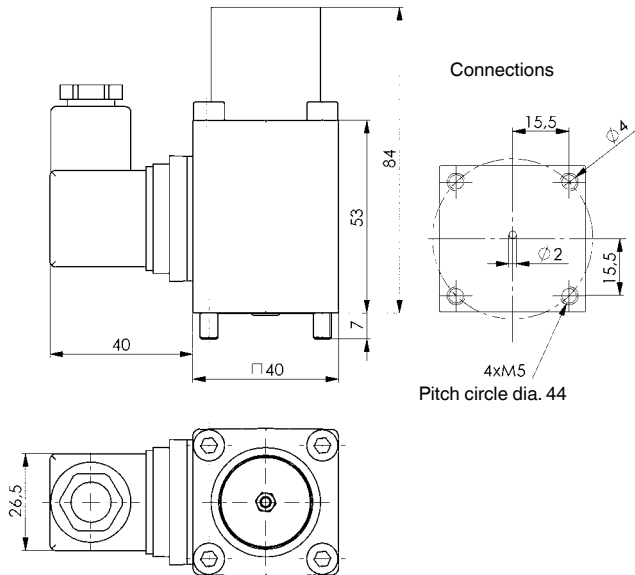

No. 6982-02-01

Connection Plate

for piston pressure switch No. 6982-02 and -04.

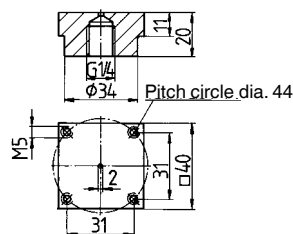

Order no.	Article no.	Weight [g]
60780	6982-02-01	185

Application:

For connecting pressure switch No. 6982-02.

No. 6982-**

Piston Pressure Switch

electric-hydraulic

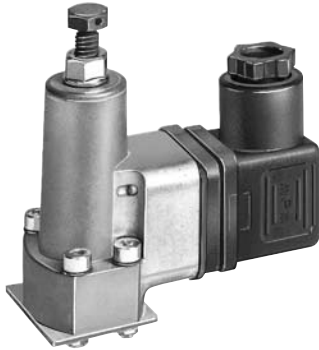
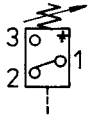

Order no.	Article no.	Operating pressure [bar]	Temp. [°C]	Mounting position	Code class	Weight [g]
492256	6982-07	12-170	-20 - +80	any	IP65	300
136291	6982-06	20-210	-20 - +80	any	IP 65	300
402610	6982-08	100-400	-20 - +80	any	IP 65	300
276881	6982-05	200-630	-20 - +80	any	IP 65	300

Application:

For electric-hydraulic pressure monitoring of a clamping circuit. The piston pressure switch can be mounted onto an adapter plate for tube connection.

Note:

Spare O-rings can be ordered with the order No. 161802 for item number 6982-05 and under order No. 161810 for item number 6982-06, -07 and -08.

Dimensions

Order no.	Article no.	Switch type	Switching frequency [1/min]	Voltage	Type
492256	6982-07	microswitch	30	4A at 230V, 4A at 12V	spring-loaded piston
136291	6982-06	microswitch	30	4A at 230V, 4A at 12V	
402610	6982-08	microswitch	30	4A at 230V, 4A at 12V	
276881	6982-05	microswitch	30	4A at 230V, 4A at 12V	

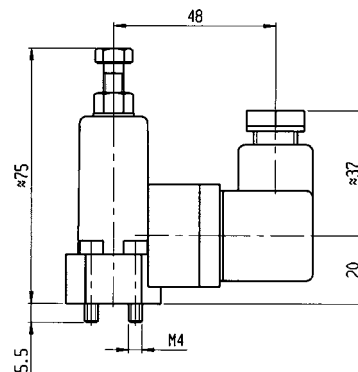
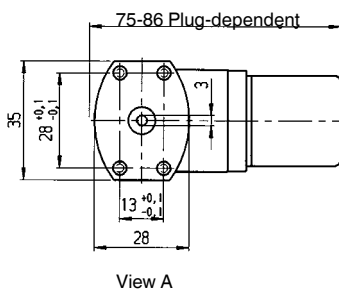

No. 6982-05-01

Flange with pipe socket

for piston pressure switch No. 6982-05, -06, -07 and -08.

Order no.	Article no.	Weight [g]
497636	6982-05-01	36

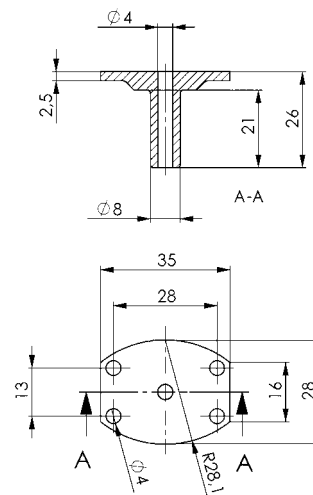

No. 6916-04 Line Check Valve

max. operating pressure 630 bar

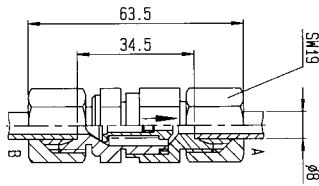
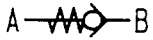

Order no.	Article no.	Pressure max. [bar]	Flow [l/min]	Differenz p at flow [bar]	Ambient temp. [°C]	Aperture pressure [bar]	Weight [g]
62885	6916-04	630	12	3	-20 - +90	1	110

Design:

Housing made of steel, surface galvanized. Sealing cone spring loaded with O-ring sealing. Seals made of Perbunan.

Note:

The direction of flow is indicated on the hex nut housing by means of an arrow. The pipe connection is sealed by means of a cutting ring.

No. 6916-05/06 Threaded Check Valve

max. operating pressure 630 bar

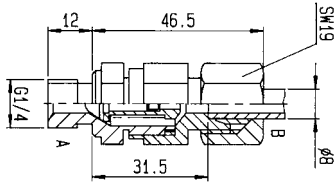

Order no.	Article no.	Pressure max. [bar]	Direction of flow	Flow [l/min]	Differenz p at flow [bar]	Ambient temp. [°C]	Aperture pressure [bar]	Weight [g]
62901	6916-05	630	A - B	12	3	-20 - +90	1	95
62968	6916-06	630	B - A	12	3	-20 - +90	1	95

Design:

Housing made of steel, surface galvanized. Sealing cone spring loaded with O-ring sealing. Sealings made of Perbunan.

Note:

The direction of flow is indicated on the hex nut housing by means of an arrow. On the threaded side sealing is done by means of a sealing edge and on the pipe side the valve is sealed by means of a cutting ring.

No. 6916-07 Shuttle Valve

max. operating pressure 630 bar

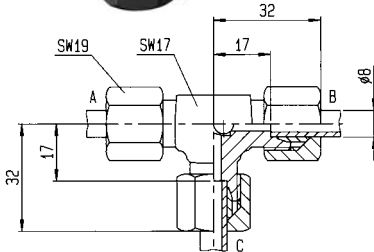
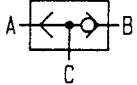

Order no.	Article no.	Pressure max. [bar]	Direction of flow	Flow [l/min]	Differenz p at flow [bar]	Ambient temp. [°C]	Weight [g]
62984	6916-07	630	A-C or B-C	18	12	-20 - +100	160

Design:

Housing made of steel, surface galvanized. Ball seat valve type.

Application:

By means of two input connections which can be shut and an output connection the alternating valve connects A or B with C according to the present pressurized line; the other connection is closed by means of a ball.

Note:

Attention: The hydraulic line empties itself when not under pressure. The pipe connection is sealed by means of a cutting ring.

No. 6916-08 Check valve, hydraulically pilot operated

max. operating pressure 700 bar

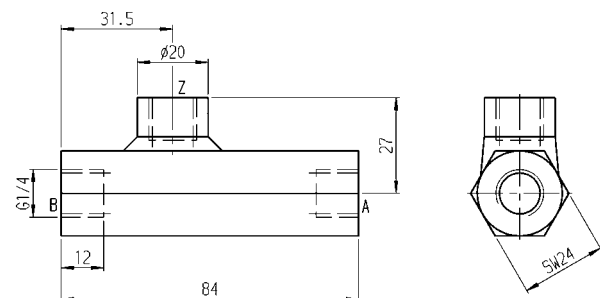
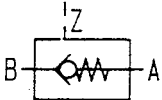

Order no.	Article no.	Pressure max. [bar]	Flow [l/min]	Differenz p at flow [bar]	Releasing ratio PA(B) / PZ	Ambient temp. [°C]	Aperture pressure [bar]	Weight [g]
60491	6916-08	700	15	8	2,7	-30 - +80	0,2 - 0,3	400

Design:

Housing made of steel, surface galvanized. Spring-loaded ball acting as a valve element. The control connection is damped by a throttle.

Diagram:

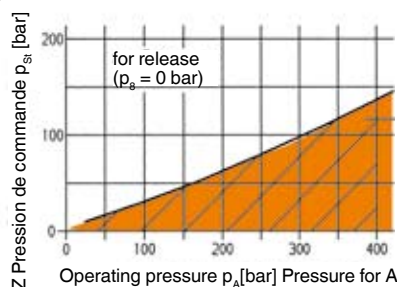

No. 6916-09
Throttle/Check Valve

max. operating pressure 400 bar.

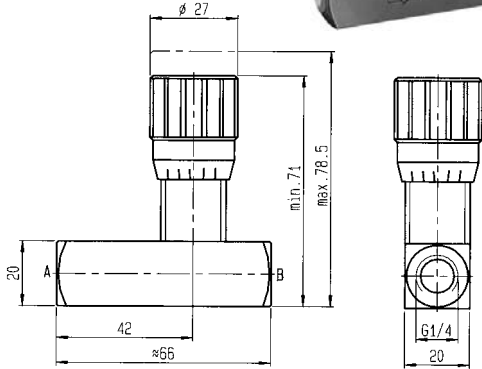
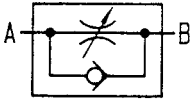

Order no.	Article no.	Pressure max. [bar]	Throttle direction	Flow [l/min]	Ambient temp. [°C]	Aperture pressure [bar]	Weight [g]
62992	6916-09	400	A - B	15	-20 - +80	0,35	250

Design:

Housing made of steel, galvanized. Adjusting knob made of AL, ribbed. Needle throttle.

Note:

Easy setting by scaled spindle and adjusting knob.

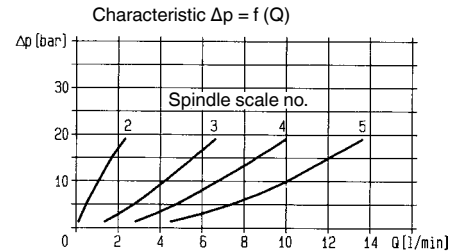
Diagram:

No. 6916-10
Throttle/Check Valve

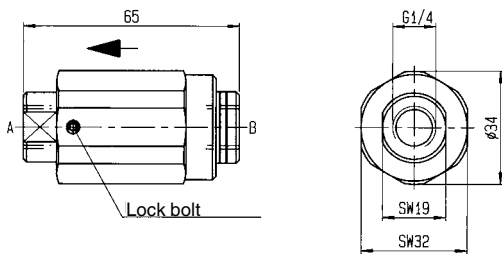
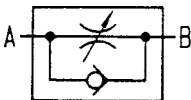
max. operating pressure 400 bar.



Order no.	Article no.	Pressure max. [bar]	Throttle direction	Flow [l/min]	Ambient temp. [°C]	Aperture pressure [bar]	Weight [g]
63008	6916-10	400	A - B	18	-30 - +80	3	290

Design:

Housing made of steel, blued. Blued throttle socket.

Note:

A constant flow is achieved by means of the new oil dosing curves as from 0.04 l/min. The valve can be easily adjusted under high pressure.

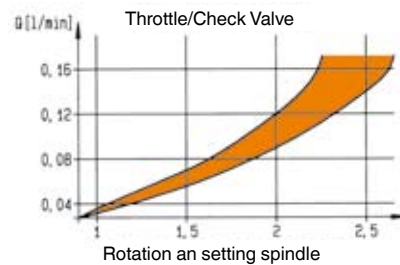
Diagram:

No. 6916-11
Ball-Valve

max. operating pressure 500 bar.



Order no.	Article no.	Pressure max. [bar]	Oilflow bore DN (dia.)	Ambient temp. [°C]	Weight [g]
65326	6916-11	500	Ø 6	-20 - +100	350

Design:

Housing and functioning components made of steel. Seal of shaft made of NBR.

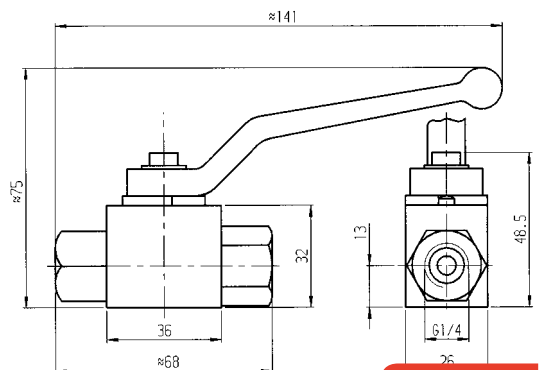

No. 6989M

Screw-in Coupling Mechanism

max. operating pressure 400 bar.

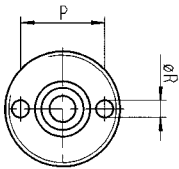
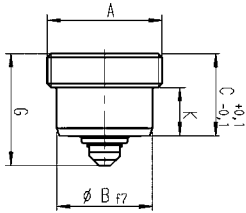

Installation geometry

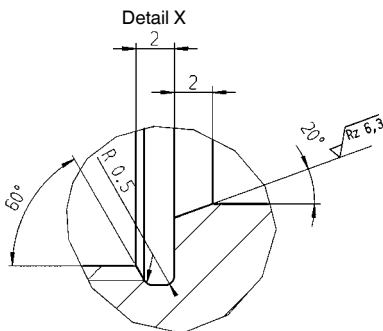
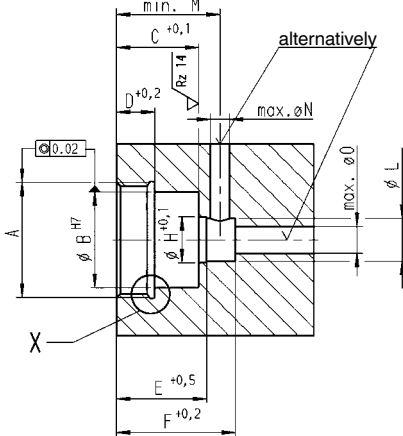

Order no.	Article no.	For coupling under pressure	For pressure-free coupling	Thread [A]	Nominal bore [NW]	Weight [g]
324491	6989M-05-001	✓	-	M20x1,5	3	40
324517	6989M-06-002	-	✓	M20x1,5	3	40
164970	6989M-10-001	✓	-	M24x1,5	5	72
164996	6989M-20-002	-	✓	M24x1,5	5	72

Design:

Cylinder body and internal parts made of stainless steel. Seals from NBR, Viton, POM and PU.

Application:

Couplings are used for the leakage-free connection of hydraulic oil supplies. The coupling elements are installed in a body. The sealing between coupling mechanism and nipple is axial, and installed in the coupling mechanism. If the seal is worn, it can be replaced. The coupling mechanism must always be used in combination with a nipple of the same system. Depending on the version, the couplings can be connected and disconnected at the maximum working pressure. When installed in a tank line, a coupling nipple with pressure relief must be selected. This limits the pressure that can be built up in the uncoupled state (for example due to internal leakage of the clamping elements) to approx 5 bar. When the two parts of the coupling are engaged, the pressure relief is no longer active.

Features:

For connection, the coupling mechanism and nipple must be axially aligned. The bodies of the two parts must be guided when the axial sealing surfaces are ca. 2-3 mm apart. The radial position tolerance must not be exceeded. The separating force due to hydraulic pressure is given by the formula NW3: $F [N] = 9,4 \times p [\text{bar}]$, NW5: $F [N] = 15,4 \times p [\text{bar}]$. This separating force must be countered by some external, mechanical means. The coupling mechanism must seal at the bottom of the hole in which it is installed. The mounting hole must be machined to the specified accuracy and surface finish.

Note:

The axial sealing surfaces must be protected from dirt. Because the coupling halves have smooth, uninterrupted sealing surfaces, the danger of them collecting dirt is reduced, and the ease with which the user can clean them before the joint is made is increased. Good results can be achieved by washing them off and blowing clean with compressed air. Positioning tolerance in axial direction for all coupling elements: +0.5 mm. Positioning tolerance in radial direction for coupling nipple: +/- 0.2 mm.

On request:

Other sizes available on request.

Dimensions

Order no.	Article no.	B	C	D	E	F	G	H	K	L	M	N	O	P	R
324491	6989M-05-001	18	21,5	10	23,5	31	29	12	12,5	11,2	28	5	7	15,5	2 x 2,6
324517	6989M-06-002	18	21,5	10	23,5	31	29	12	12,5	11,2	28	5	7	15,5	2 x 2,6
164970	6989M-10-001	22	21,5	10	23,5	31	29	12	12,5	11,2	28	5	7	18,5	4 x 2,8
164996	6989M-20-002	22	21,5	10	23,5	31	29	12	12,5	11,2	28	5	7	18,5	4 x 2,8

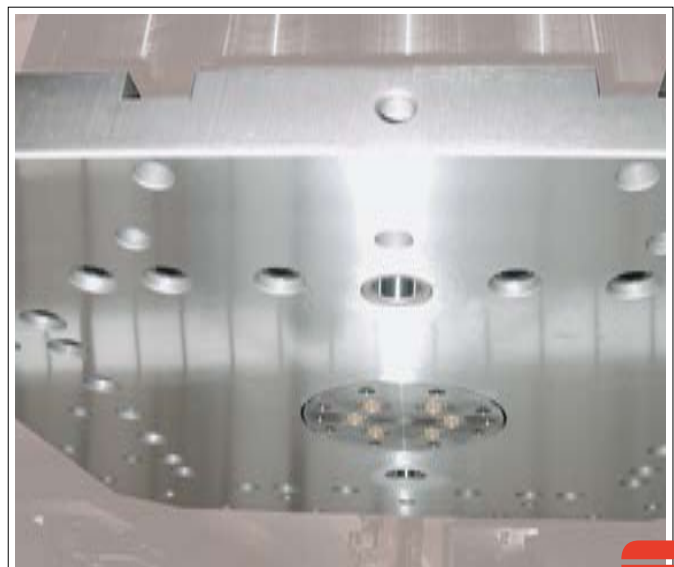

Subject to technical alterations.

No. 6989N

Screw-In Coupling Nipple

max. operating pressure 400 bar.

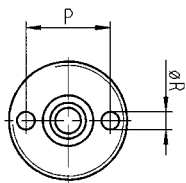
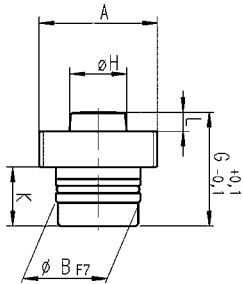

Installation geometry

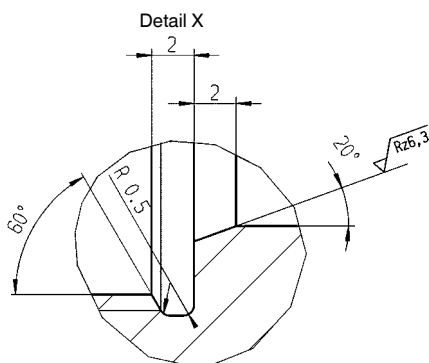
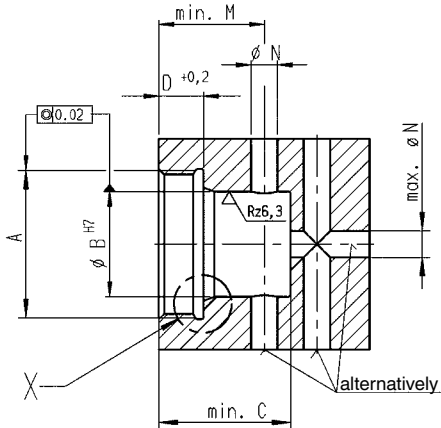

Order no.	Article no.	For coupling under pressure	For pressure-free coupling	With pressure relief	Thread [A]	Nominal bore [NW]	Weight [g]
324509	6989N-05-001	✓	-	-	M20x1,5	3	30
324525	6989N-06-002	-	✓	-	M20x1,5	3	30
164962	6989N-10-001	✓	-	-	M24x1,5	5	56
164988	6989N-20-002	-	✓	-	M24x1,5	5	56

Design:

Cylinder body and internal parts made of stainless steel. Seals from NBR, Viton, POM and PU.

Application:

Couplings are used for the leakage-free connection of hydraulic oil supplies. The coupling elements are installed in a body. The sealing between coupling mechanism and nipple is axial, and installed in the coupling mechanism. If the seal is worn, it can be replaced. The coupling mechanism must always be used in combination with a nipple of the same system. Depending on the version, the couplings can be connected and disconnected at the maximum working pressure. When installed in a tank line, a coupling nipple with pressure relief must be selected. This limits the pressure that can be built up in the uncoupled state (for example due to internal leakage of the clamping elements) to approx 5 bar. When the two parts of the coupling are engaged, the pressure relief is no longer active.

Features:

For connection, the coupling mechanism and nipple must be axially aligned. The bodies of the two parts must be guided when the axial sealing surfaces are ca. 2-3 mm apart. The radial position tolerance must not be exceeded. The separating force due to hydraulic pressure is given by the formula NW3: $F [N] = 9,4 \times p [\text{bar}]$, NW5: $F [N] = 15,4 \times p [\text{bar}]$. This separating force must be countered by some external, mechanical means. The mounting hole must be machined to the specified accuracy and surface finish.

Note:

The axial sealing surfaces must be protected from dirt. Because the coupling halves have smooth, uninterrupted sealing surfaces, the danger of them collecting dirt is reduced, and the ease with which the user can clean them before the joint is made is increased. Good results can be achieved by washing them off and blowing clean with compressed air.

Positioning tolerance in axial direction for all coupling elements: +0.5 mm.

Positioning tolerance in radial direction for coupling nipple: +/- 0.2 mm.

On request:

Other sizes available on request.

Dimensions

Order no.	Article no.	B	C	D	G	H	K	L	M	N	P	R
324509	6989N-05-001	16	23	8,4	25,9	9,8	13	4,5	22	3	15,0	2 x 2,6
324525	6989N-06-002	16	23	8,4	25,9	9,8	13	4,5	22	3	15,0	2 x 2,6
164962	6989N-10-001	20	25	8,5	27,0	13,5	14	4,5	20	5	18,5	4 x 2,8
164988	6989N-20-002	20	25	8,5	27,0	13,5	14	4,5	20	5	18,5	4 x 2,8

Diagram:

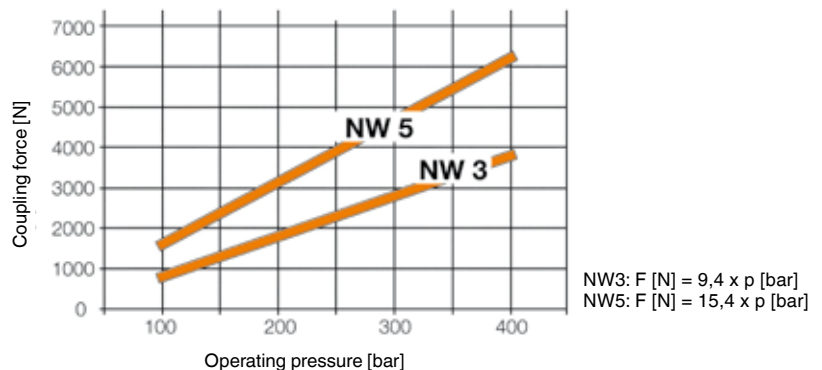

No. 6991-02

Angle Swivel Joint, 90° single passage

max. operating pressure 400 bar.

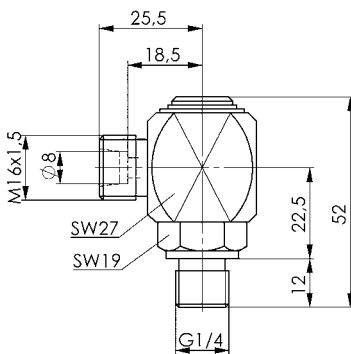

Order no.	Article no.	NG	Max. operating pressure [bar]	max. torque [Nm]	max. r.p.m. [1/min]	Permissible torque of G1/4 [Nm]	Ambient temp. [°C]	Weight [g]
69104	6991-02	4	400	0,5	25	40	-30 - +80	180

Design:

Steel galvanized. With union nut and cutting ring.

Application:

Rotary couplings are used to supply hydraulic oil to systems which can be rotated and swivelled.

Note:

Please observe max. operating pressure and max. rpm. Thread G1/4 is sealed by means of a sealing edge according to DIN 3852 Part 2, form B.

No. 6991-01

Axial Swivel Joint, single passage

max. operating pressure 400 bar.

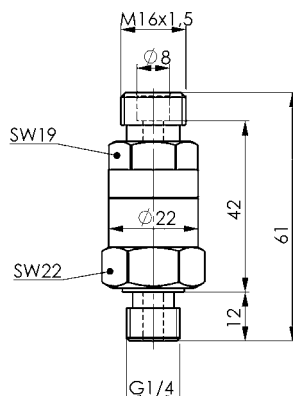

Order no.	Article no.	NG	Max. operating pressure [bar]	max. torque [Nm]	max. r.p.m. [1/min]	Permissible torque of G1/4 [Nm]	Ambient temp. [°C]	Weight [g]
69088	6991-01	4	400	0,5	25	40	-30 - +80	140

Design:

Steel galvanized and yellow passivated. With union nut and cutting ring.

Application:

Rotary couplings are used to supply hydraulic oil to systems which can be rotated and swivelled.

Note:

Please observe max. operating pressure and max. rpm. Thread G1/4 is sealed by means of a sealing edge according to DIN 3852 Part 2, form B.

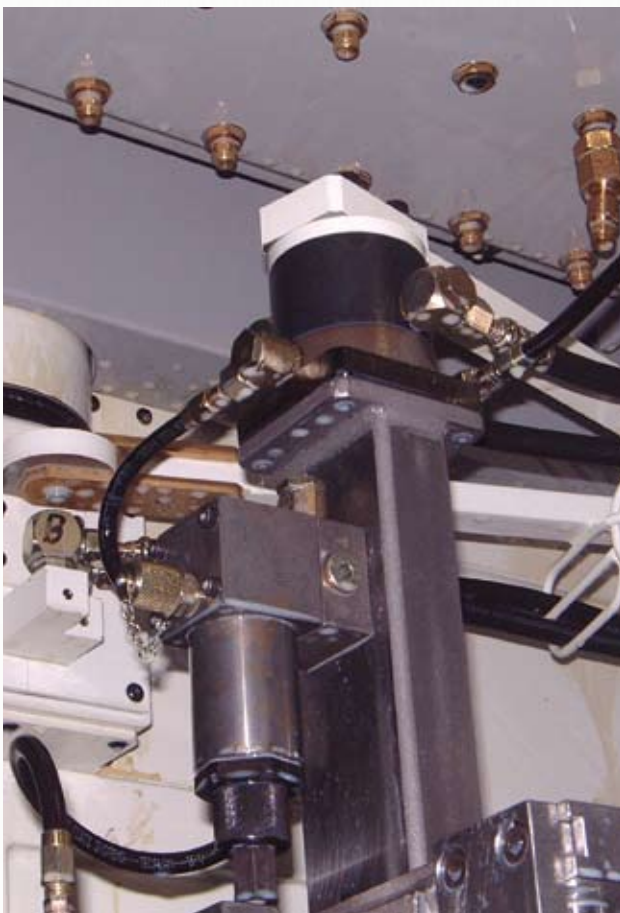
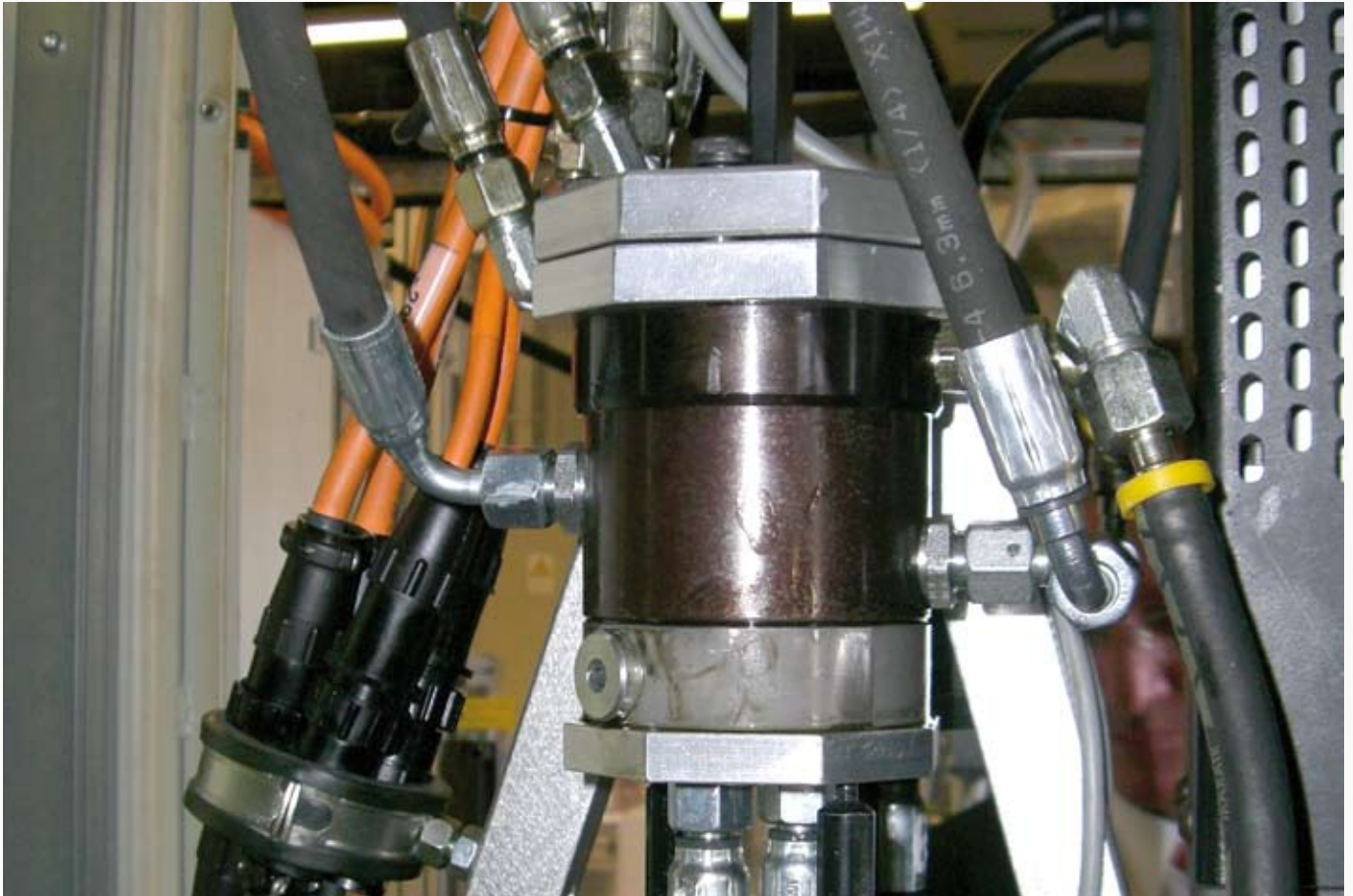

No. 6991-x0 Rotary coupling

overflow oil connection not included,
max. operating pressure 350 bar



Order no.	Article no.	Con-nections inputs	Con-nections outputs	Ambient temp. [°C]	max. torque [Nm]	max. r.p.m. [1/min]	NG	Weight [Kg]
334185	6991-20	2	2	-10 - +60	5,0	85	5	2,2
323451	6991-40	4	4	-10 - +60	7,5	48	5	3,8
323477	6991-60	6	6	-10 - +60	14,0	40	5	5,8

Design:

Rotary coupling housing of ductile cast iron with radial G1/4 oil connections. Rotary pistons of nitrided tempered steel with radial and axial G1/4 oil connections. The counter-sinks in the axial connections can be used as O-ring connections. Required O-ring 16x2 (order no. 136069).

Application:

Rotary couplings transmit flows of hydraulic oil from a stationary machine component to a rotating one. They are located in the rotary axis of a rotating system. The rotary couplings are generally designed for hydraulic systems. To transmit air flows, they have to be filtered, oiled, and free of water. Single-acting and double-acting cylinders can be connected. Each cylinder channel requires a separate connection on the housing and on the rotor.

Features:

Because of the high-grade seal packages it is possible to operate at high pressures. Multistrand rotary oil couplings. Long service life. Compact design.

Note:

Max. pressure and max. rpm must not occur together. See diagrams.
The rotary couplings must be operated without bending forces. We recommend that you screw the rotating housing with the connections to the clamping fixtures and secure the rotary piston only against twisting. Do not introduce any bearing loads! The line connections to the rotary piston must always be made with hoses.
The frictional resistance on the seals is pressure-dependent. This must be taken into account when calculating the drive torque for the rotary table. The rotary couplings are fundamentally designed for intermittent operation.
Special versions available on request. See diagrams for minimum and maximum load data.

Diagrams:

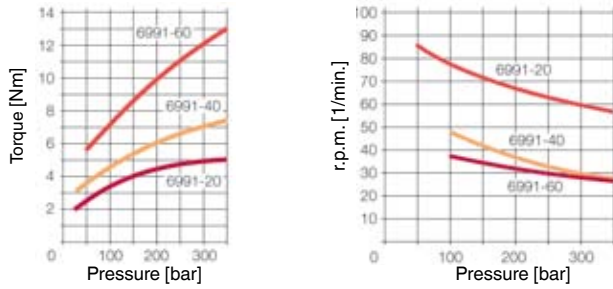

No. 6991-20

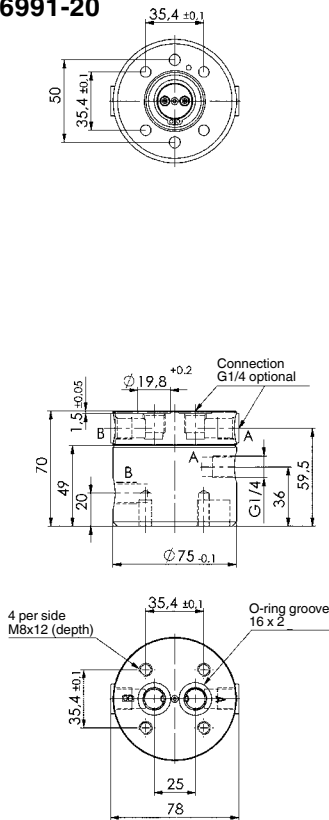

No. 6991-40

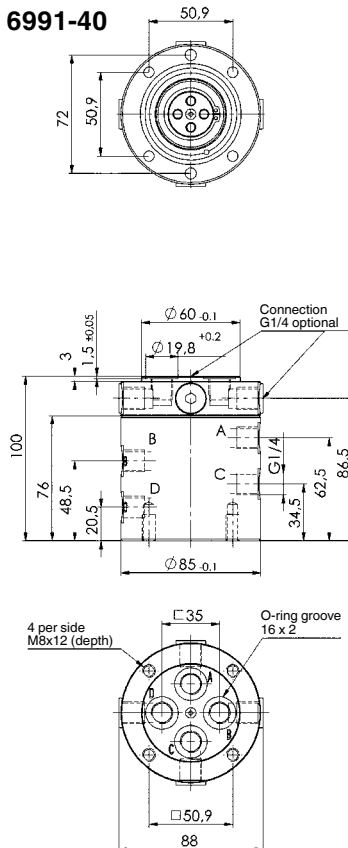

No. 6991-60

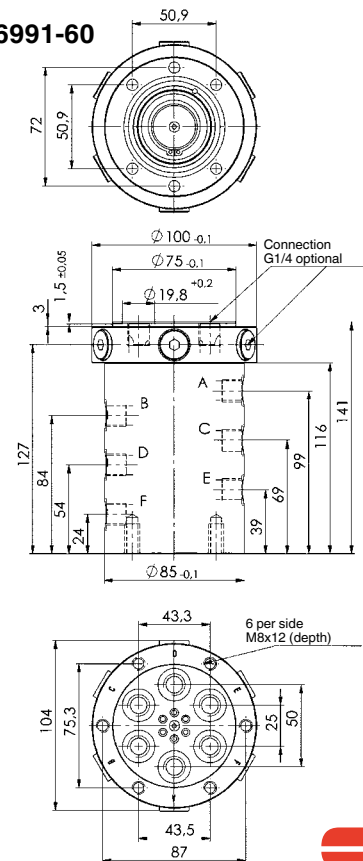

Subject to technical alterations.

No. 6991-x1

Rotary coupling

with overflow oil connection,
max. operating pressure 350 bar



Order no.	Article no.	Con-nections inputs	Con-nections outputs	Ambient temp. [°C]	max. torque [Nm]	max. r.p.m. [1/min]	NG	Weight [Kg]
445536	6991-21	2	2	-10 - +60	5,0	85	5	2,5
323493	6991-41	4	4	-10 - +60	7,5	48	5	4,2
323519	6991-61	6	6	-10 - +60	14,0	40	5	6,2

Design:

Rotary coupling housing of ductile cast iron with radial G1/4 oil connections. Rotary pistons of nitrided tempered steel with radial and axial G1/4 oil connections. The counter-sinks in the axial connections can be used as O-ring connections. Required O-ring 16x2 (order no. 136069). Cover of tempered steel with radial G1/8 oil connection for removing overflow oil.

Application:

Rotary couplings transmit flows of hydraulic oil from a stationary machine component to a rotating one. They are located in the rotary axis of a rotating system. The rotary couplings are generally designed for hydraulic systems. To transmit air flows, they have to be filtered, oiled, and free of water. Single-acting and double-acting cylinders can be connected. Each cylinder channel requires a separate connection on the housing and on the rotor.

Features:

Because of the high-grade seal packages it is possible to operate at high pressures. Multistrand rotary oil couplings. Long service life. Compact design.

Note:

Max. pressure and max. rpm must not occur together. See diagrams. The rotary couplings must be operated without bending forces. We recommend that you screw the rotating housing with the connections to the clamping fixtures and secure the rotary piston only against twisting. Do not introduce any bearing loads! The line connections to the rotary piston must always be made with hoses. The frictional resistance on the seals is pressure-dependent. This must be taken into account when calculating the drive torque for the rotary table. The rotary couplings are fundamentally designed for intermittent operation. Special versions available on request. See diagrams for minimum and maximum load data.

Diagrams:

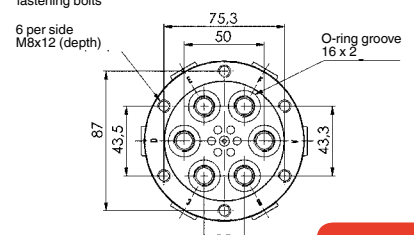
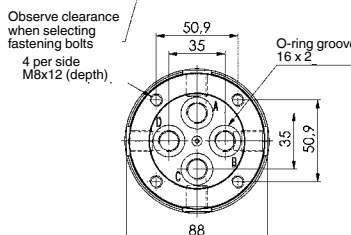
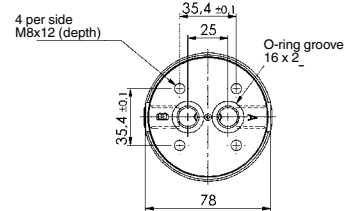
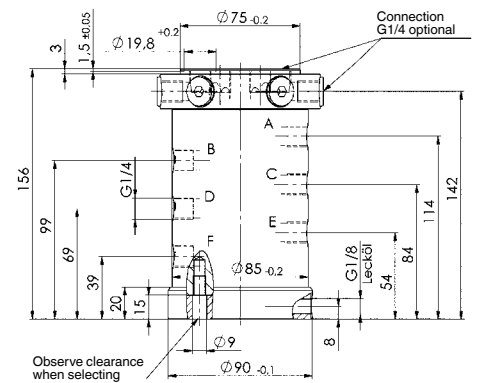
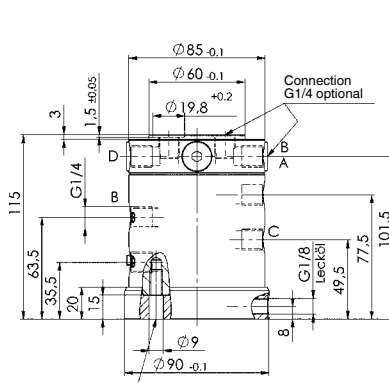
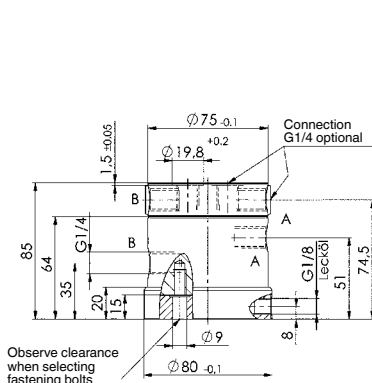
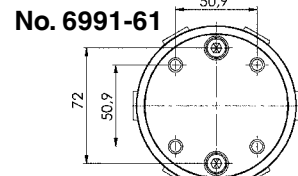
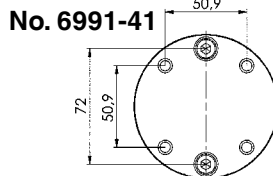
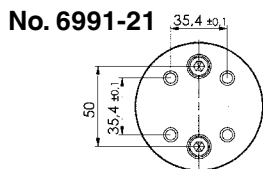
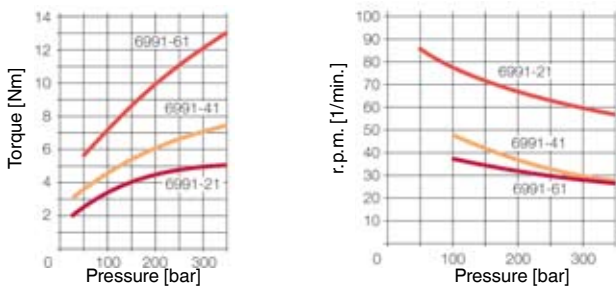

No. 6992H-11

Rotary coupling

controlled, single-acting.
One loading and unloading station,
max. operating pressure 350 bar

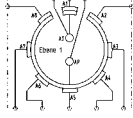

Order no.	Article no.	Connections				Ambient temp. [°C]	max. oil flow rate [Nm]	NG	Weight [Kg]
		inputs loading	inputs processing	utputs loading	outputs processing				
324533	6992H-11-06	1	1	1	5	-10 - +60	8	5	3,6
324541	6992H-11-08	1	1	1	7	-10 - +60	8	5	3,5
324558	6992H-11-10	1	1	1	9	-10 - +60	8	5	3,5

Design:

Rotary coupling housing of ductile cast iron with radial G1/4 oil connections. Rotary pistons of nitrided tempered steel with radial and axial G1/4 oil connections. The countersinks in the axial connections can be used as O-ring connections. Required O-ring 16x2 (order no. 136069).

Application:

Rotary couplings transmit flows of hydraulic oil from a stationary machine component to a rotating one. They are located in the rotary axis of a rotating system. The controlled rotary couplings may only be operated with hydraulic oil. Types 6992H-11 are designed for single-acting cylinders. One loading/unloading station and 5, 7 or 9 processing stations can be connected.

Features:

Rotary vane construction. Multiple hydraulic cylinders are supplied with hydraulic oil simultaneously. At the same time, a loading and/or unloading station can be controlled via directional valves for clamping and/or unclamping. High operating pressures due to high-quality components and seals. Compact design. Long service life.

Note:

The controlled rotary couplings can only be used for cyclic operation or at very low rpms. The rotary couplings must be operated without bending forces. We recommend that you screw the rotating housing with the connections to the clamping fixtures, and to secure the rotary pistons only against twisting. Do not introduce any bearing loads! The connections to the rotary pistons must always be via hoses. At operating pressures above 200 bar oil losses occur when the loading and unloading station are unloaded; this can be compensated for using an accumulator. The accumulator that is selected must have the appropriate safety equipment and comply with the safety regulation of the country concerned. We recommend the use of directional seat valves for controlling the rotary couplings.

No. 6992H-11-06

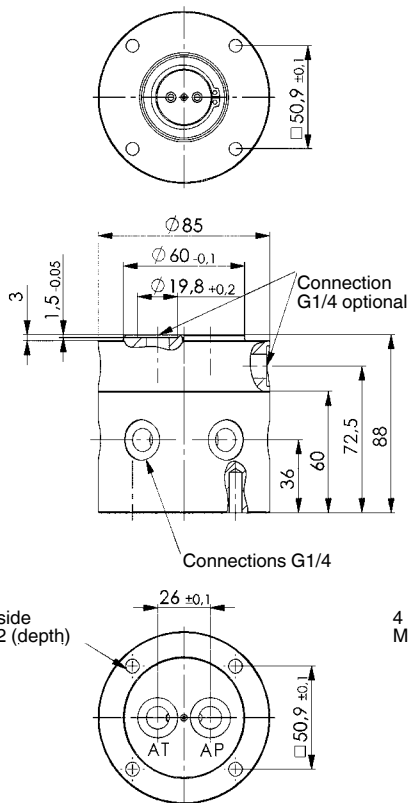

No. 6992H-11-08

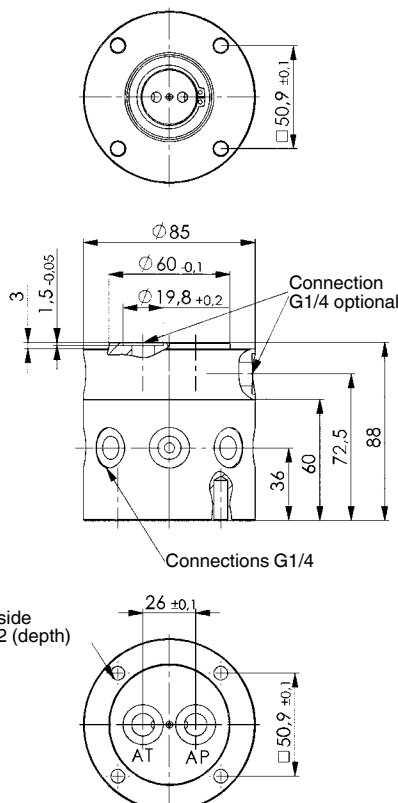

No. 6992H-11-10

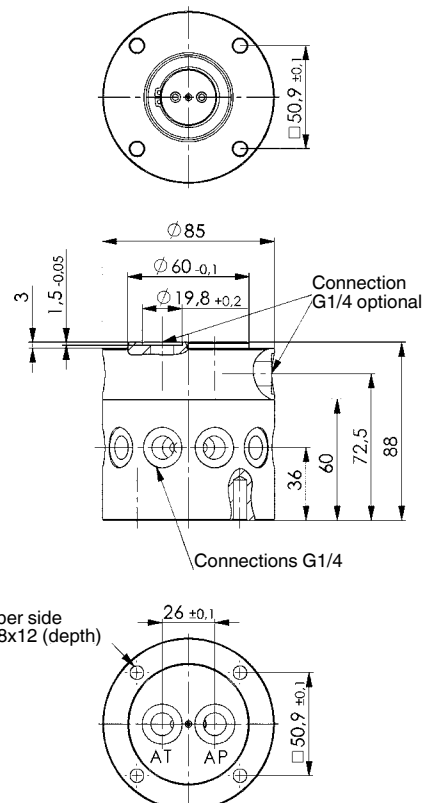

Application example:

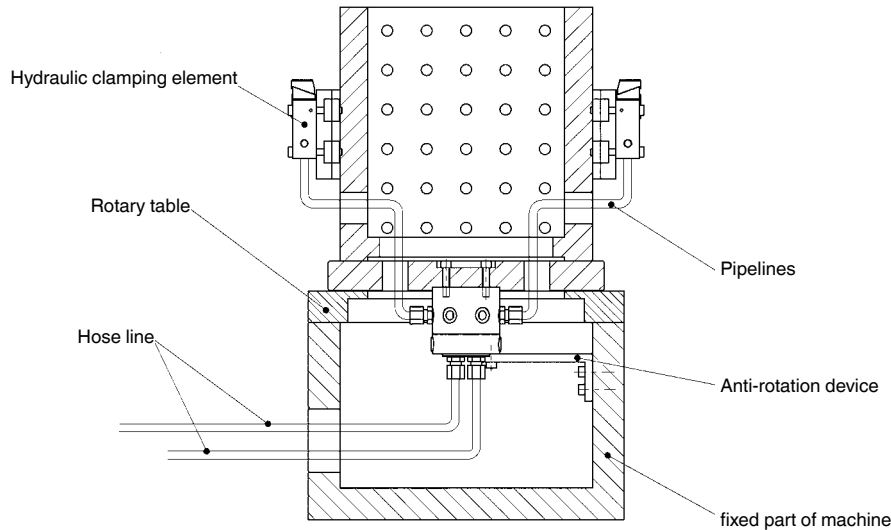

Hydraulic diagram - example:

Example of schematic:

Rotary union, ew', controlled, 1 x loading, 7 x machining

The loading and unloading station is controlled by a 3/2 way valve.

The machining stations are directly controlled by the pump.

The separation of loading and unloading station and machining stations by the rotary union is not leakage-free.

Leakage increases with pressure.

A pressure accumulator can be used for leakage compensation.

The next cycle must only be performed when the loading or unloading station is clamped.

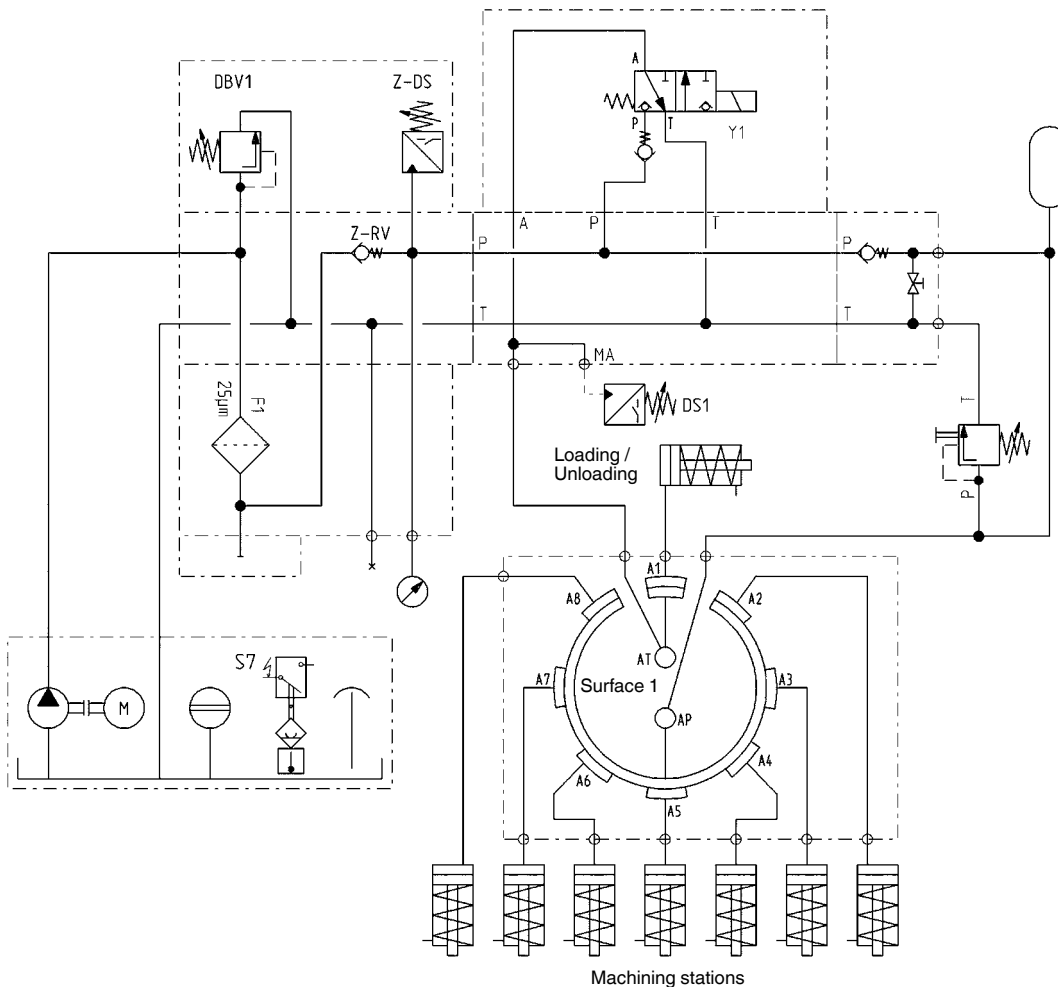

No. 6992H-21

Rotary coupling

controlled, double-acting.
One loading and unloading station,
max. operating pressure 350 bar

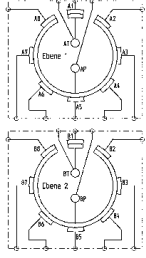

Order no.	Article no.	Connections				Ambient temp. [°C]	max. oil flow rate [Nm]	NG	Weight [Kg]
		inputs loading	inputs processing	outputs loading	outputs processing				
324566	6992H-21-06	2	2	2	10	-10 - +60	8	5	4,1
324574	6992H-21-08	2	2	2	14	-10 - +60	8	5	4,0
324582	6992H-21-10	2	2	2	18	-10 - +60	8	5	3,9

Design:

Rotary coupling housing of ductile cast iron with radial G1/4 oil connections. Rotary pistons of nitrided tempered steel with radial and axial G1/4 oil connections. The countersinks in the axial connections can be used as O-ring connections. Required O-ring 16x2 (order no. 136069).

Application:

Rotary couplings transmit flows of hydraulic oil from a stationary machine component to a rotating one. They are located in the rotary axis of a rotating system. The controlled rotary couplings may only be operated with hydraulic oil. Types 6992H-21 are designed for double-acting cylinders. One double-acting loading/unloading station and 5, 7 or 9 double-acting processing stations can be connected.

Features:

Rotary vane construction. Multiple hydraulic cylinders are supplied with hydraulic oil simultaneously. At the same time, a loading and/or unloading station can be controlled via directional valves for clamping and/or unclamping. High operating pressures due to high-quality components and seals. Compact design. Long service life.

Note:

The controlled rotary couplings can only be used for cyclic operation or at very low rpms. The rotary couplings must be operated without bending forces. In contrast to the uncontrolled versions, we recommend that you screw the rotating housing with the connections to the clamping fixtures, and to secure the rotary pistons only against twisting. Do not introduce any bearing loads! The connections to the rotary pistons must always be via hoses. At operating pressures above 200 bar oil losses occur when the loading and unloading station are unloaded; this can be compensated for using an accumulator. The accumulator that is selected must have the appropriate safety equipment and comply with the safety regulation of the country concerned. We recommend the use of directional seat valves for controlling the rotary couplings.

No. 6992H-21-06

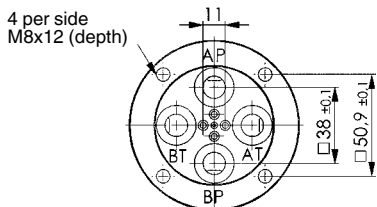
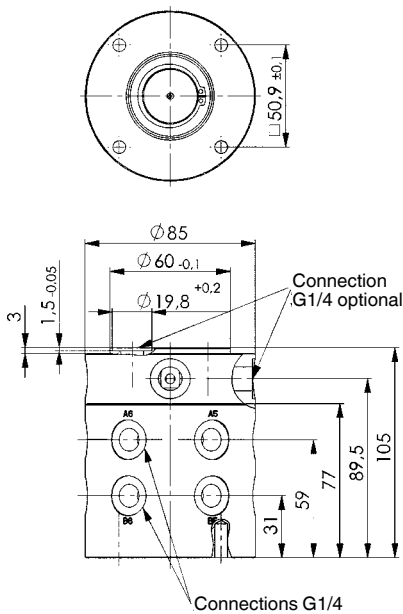

No. 6992H-21-08

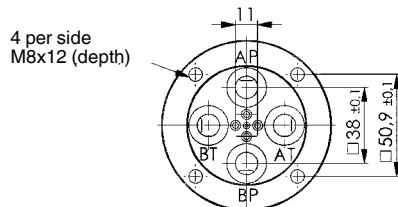
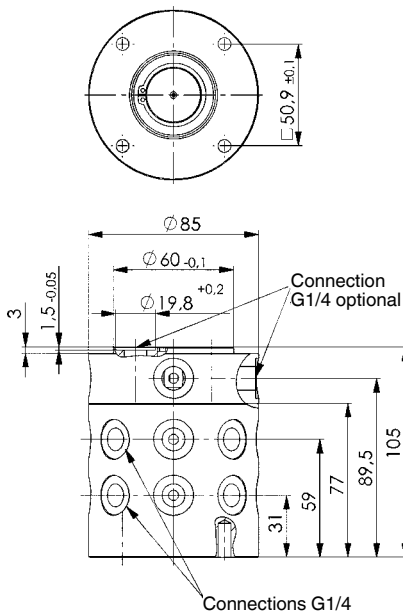

No. 6992H-21-10

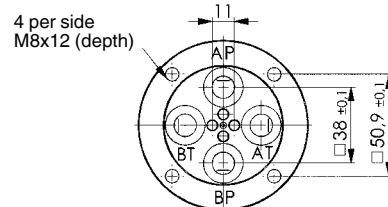
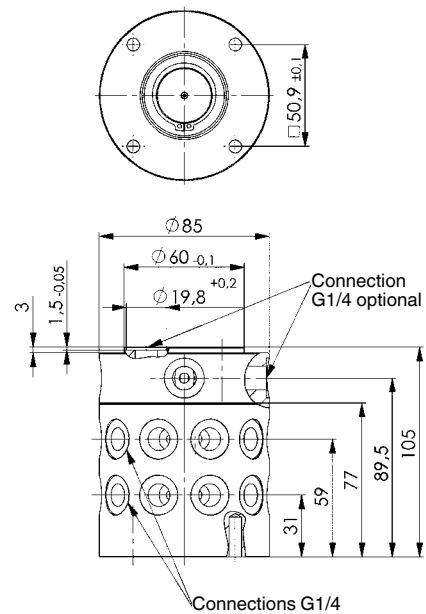

Subject to technical alterations.

Application example:

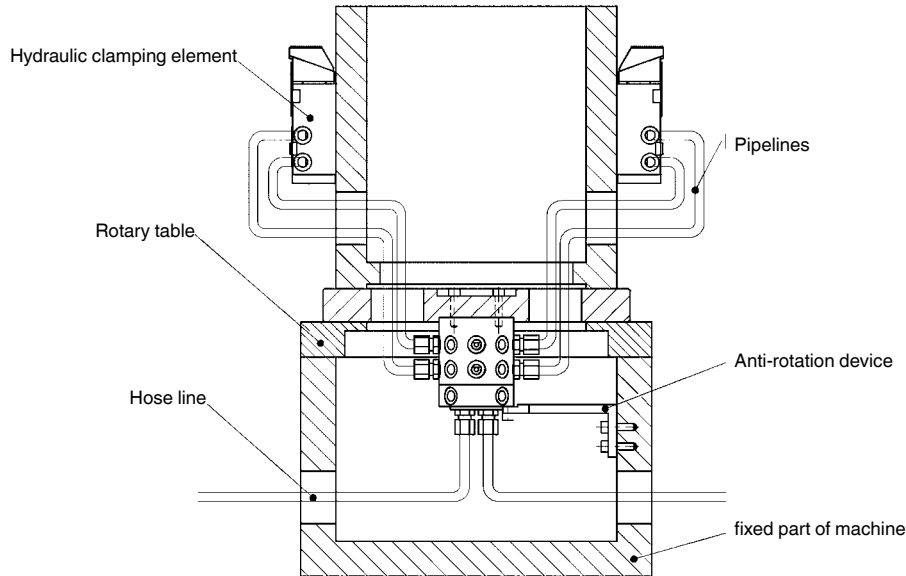

Hydraulic diagram - example:

Example of schematic:

Rotary union, dw', controlled, 1 x loading, 7 x machining

The loading and unloading station is controlled by a 4/3 way valve.

The machining stations are directly controlled by the pump.

The separation of loading and unloading station and machining stations by the rotary union is not leakage-free.

Leakage increases with pressure.

A pressure accumulator can be used for leakage compensation.

The next cycle must only be performed when the loading or unloading station is clamped.

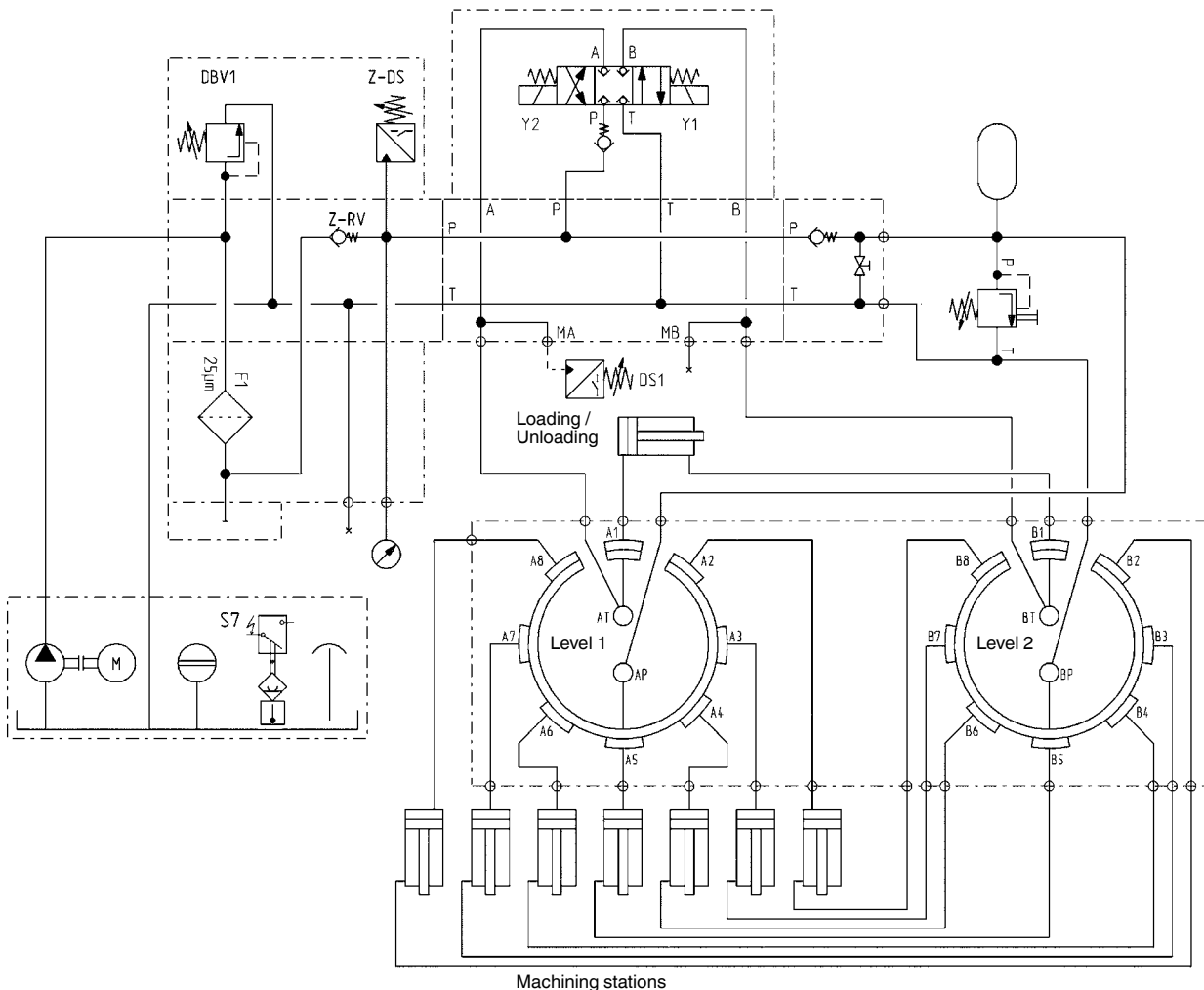

No. 6919-2

Pallet Decoupler Block

for single acting cylinders,
max. operating pressure 400 bar.

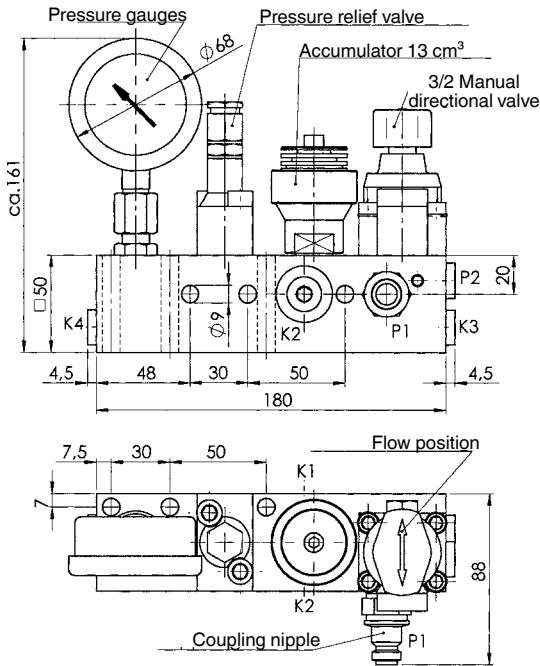

Wiring diagram:

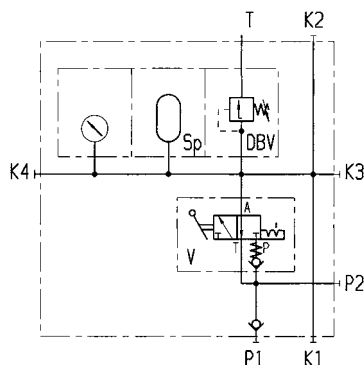

Order no.	Article no.	Set gas preload p0 [bar]	Reservoir volume [cm ³]	NG	Flow max. [l/min]	Connections inputs P1+P2	Connections outputs K1 to K4	Weight [g]
61168	6919-2	80*	13	4	7,5	G1/4	G1/4	4400

* Adjustable between 20 and 250 bar at works (on request).

Design:

- Distributor made of phosphatized steel
- 3/2-way manual seat valve
- Accumulator
- Pressure-relief valve set to 400 bar
- Pressure gauge (600 bar; nom. size 63; with glycerin damping)
- Coupling connector No. 6990 G1/4 S and fittings

Application:

The main application for the pallet decoupler block is to maintain pressure at fixtures which are disconnected from the pump unit during the machining process. For example on flexible machining centers with pallet changing systems. With tight hydraulic elements a loss in pressure shall be limited to 2 bar/h (see diagram). The integrated accumulator can compensate for a leakage-oil quantity of approx. 6 cm³ in the range from 150 to 400 bar. The pressure input is connected to P1 or P2 and absorbed by the pressure gauge.

1. Couple pump unit with pallet decoupler block.
2. Switch manual seat valve to flow.
3. Remove workpiece or insert a new.
4. Operate pump unit (clamp).
5. Once pressure has been built up (check at pressure gauge), the seat valve must be set to close.
6. Operate pump unit (unclamp).
7. The pump unit is uncoupled from the pallet decoupler block.

Features:

After disconnecting the pump unit the clamping fixture cannot be depressurized even by operating the seat valve. Compact design. Load outputs (K1 to K4).

Note:

1. If the seat valve is opened in the uncoupled condition, it cannot be coupled again. The seat valve must then be switched to close. Loosen the coupling connector SW (AF) to depressurize 22 and then tighten again.
2. The clamping point can also have pressure applied when the seat valve is set to close.

Diagram:

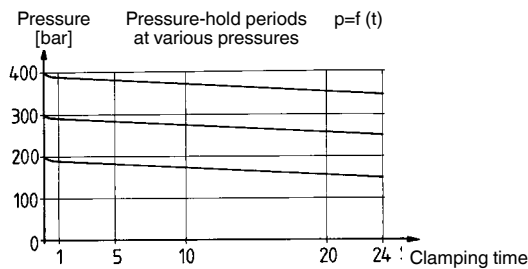

Wiring diagram symbols:

- = Pressure gauges, Order no. 161414
- SP = Accumulator, Order no. 67645
- DBV = Pressure relief valve, Order no. 181222
- V = Manual seat valve 3/2, Order no. 114298
- K1-K4 = Pressure outputs (plug), Order no. 69419
- P1 = Pressure input (coupling connector), Order no. 69039
- P2 = Pressure input (plug), Order no. 69419
- T = Release opening DBV

No. 6919S Accumulator



No. 6919S-013

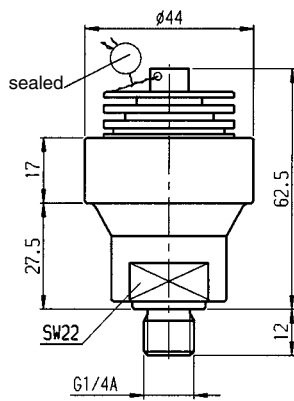

No. 6919S-040

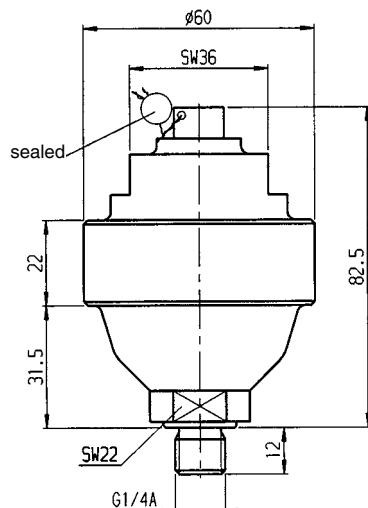

Order no.	Article no.	Reservoir volume [cm ³]	Gas preload p ₀ max. [bar]	Set gas preload p ₀ [bar]	max. perm. overpressure [bar]	Max. permissible operating pressure ratios p ₂ max : p ₁ max	Ambient temp. [°C]	Weight [g]
67645	6919S-013	13	250	80	500	4 : 1 3 : 1	-20 - +60	300
67637	6919S-040	40	250	80	400	4 : 1 3 : 1	-20 - +60	650

Design:

- Hydro diaphragm reservoir
- Filling gas = nitrogen, class 4.0
- Pressure fluid: hydraulic oil acc. to DIN 51524 Part 1 and 2; viscosity ISO VG 10 to ISO VG 68 acc. DIN 51519.
- Thread G1/4 A, DIN ISO 228/1 with sealing edge.

Application:

- For short-term compensation of oil losses in stand-by operation;
- to support during switching procedures in hydraulic circuits;
- to compensate for pressure peaks when switching valves;
- for compensation of volume changes of closed circuits in case of temperature changes.

Note:

The reservoirs are manufactured, checked and marked according the technical rules for pressure containers (TRB).

Diagram:

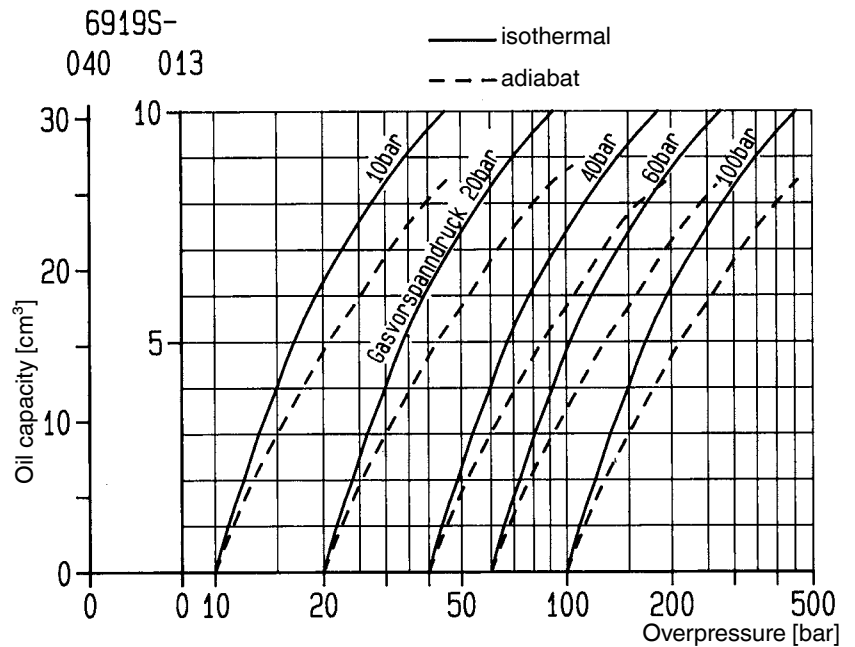

No. 6919-20

Pallet Decoupler Block

for double acting cylinders,
max. operating pressure 400 bar.

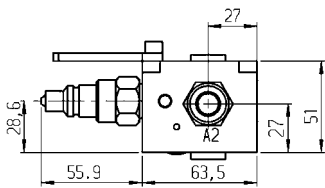
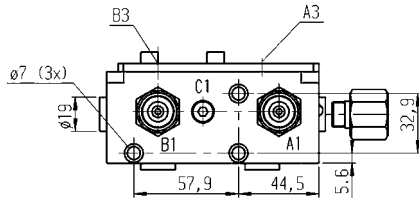
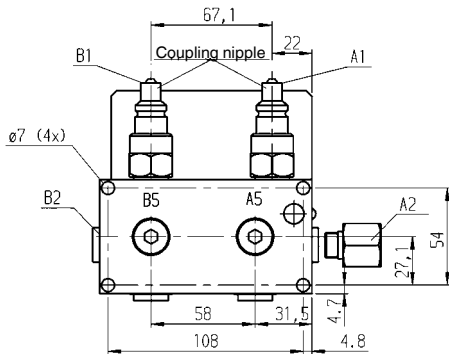
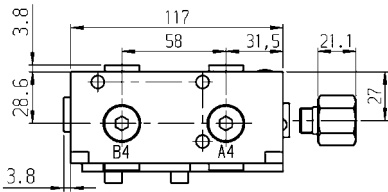

Order no.	Article no.	Flow [l/min]	Outputs clamp A2 to A5	Outputs unclamp B2 to B5	Weight [g]
320002	6919-20	7,5	G1/4	G1/4	2572

Design:

Manifold made of steel, blued. Integrated, fixed set pressure relief valve. 4 connections for consumers, pressure tank and manometer. Including coupling connector No. 6919-20S. Order no. 320010 and G1/4 adapter for connection A2. A filter is integrated in the forward and return line.

Application:

The main application for the pallet decoupler block is to maintain hydraulic pressure at fixtures which are disconnected from the pressure generator during the machining process. For example on flexible machining centers with pallet changing system. Possible small oil leakage are compensated in a particular pressure range by the attached accumulator. Please see technical details of the used accumulator (No. 6919-13 or No. 6919-40). During coupling clamping circuit and return drive circuit must be without pressure.

Note:

The use of an accumulator no. 6919S-013/040 in the clamping circuit is necessary. For visual pressure observation, a pressure gauge no. 6983-1 shall be attached.

Wiring diagram:

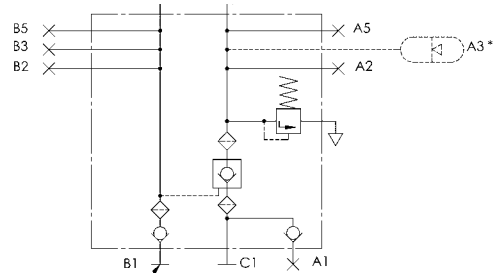

The pressure for unclamping must be at least 20% of the clamping pressure

A3* Pressure accumulator necessary for functioning.

Wiring diagram:

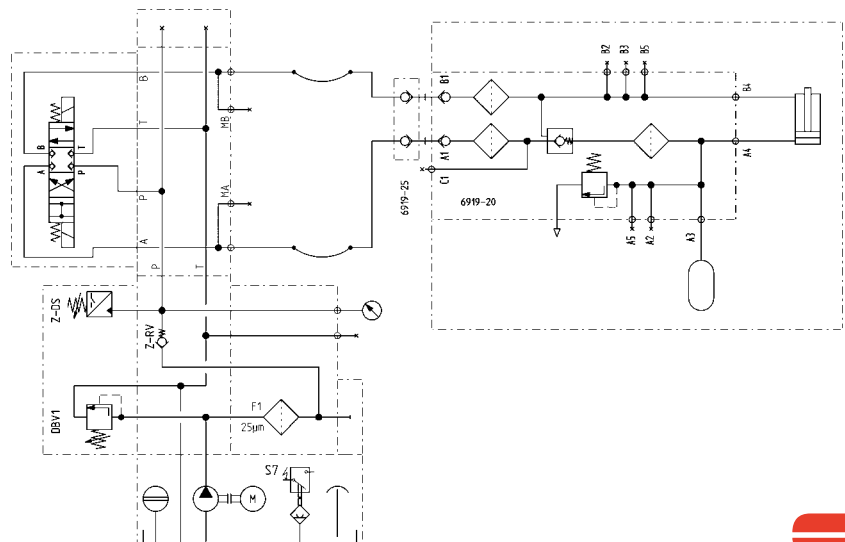

No. 6919-25

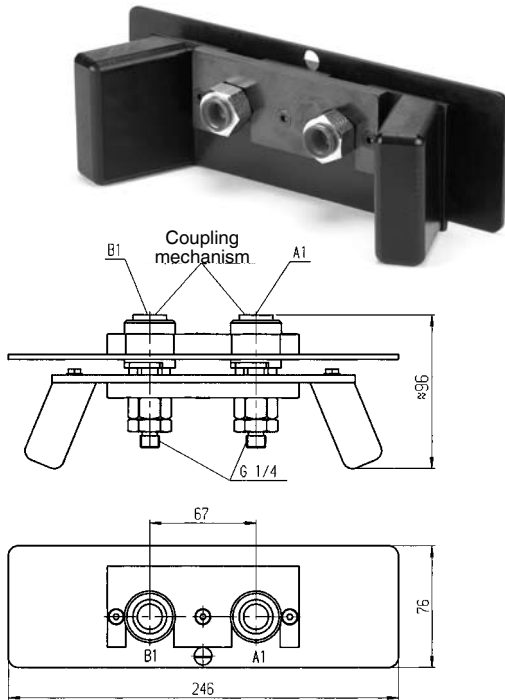

Order no.	Article no.	Flow [l/min]	Weight [g]
320028	6919-25	7,5	2200

Design:

The coupling unit consists out of two coupling mechanism for clamping and unclamping circuit. The coupling elements are mounted to an adapter with handle and disengaging mechanism.

Application:

The coupling unit is used to connect the oil supply with the pallet decoupler block No. 6919-20.

Features:

Simple handling due two hand operation. Interchanging of connections is impossible.

No. 6919-30

Store Station for Coupling Unit

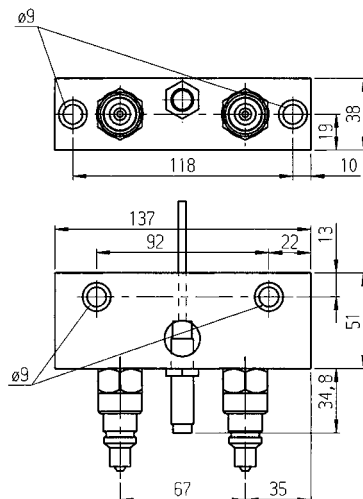

Order no.	Article no.	Weight [g]
320044	6919-30	1837

Design:

Safety sensor switch integrated.

Application:

The store station is used as holder for the coupling unit after decoupling from the pressure tank switch unit.

Features:

If used with your machine control, the signal of the safety sensor switch, can ensure that the fixture pallet cannot be moved before the coupling unit is disconnected and removed correctly from the pallet decoupler block.



No. 6981-xx-G1/4

Filter

max. operating pressure 400 bar

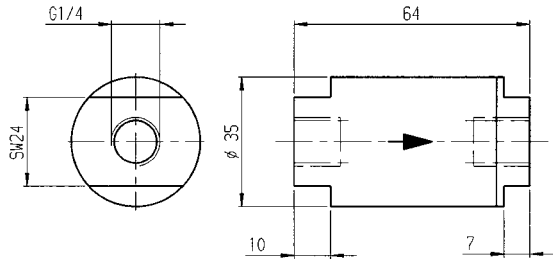
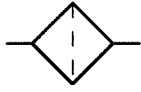

Order no.	Article no.	Filtration [µm]	Weight [g]
63966	6981-10-G1/4	10	380
320051	6981-25-G1/4	25	380
320069	6981-40-G1/4	40	380

Design:

Housing out of steel, zinc plated. Filter insert out of stainless steel, with o-ring. Pre-filtration by filter disc. Filter insert out of wire web.

Application:

The Filters are used as an additional safety in order to protect the hydraulic components in the oil circuit. The filter can be located direct in pipes, in front of distributors or in fittings.

For example:

- 10 µm input Intensifier
- 25 µm input valves
- 40 µm input pump units or hydraulic cylinder

Note:

The smaller the filtration is chosen, as bigger the flow resistance will be. The degree of pollution shall be checked. Due to the design of the housing the exchange of the filter insert is simple. The direction of oil flow has to be considered. Any built in position possible.

Threaded filter set spare parts

Order no.	Designation	Filtration [µm]	Weight [g]
320077	Filter cartridge	10	12,5
320085	Filter cartridge	25	12,5
320093	Filter cartridge	40	12,5

No. 6981E-xx-G1/4

Filter

max. operating pressure 400 bar.

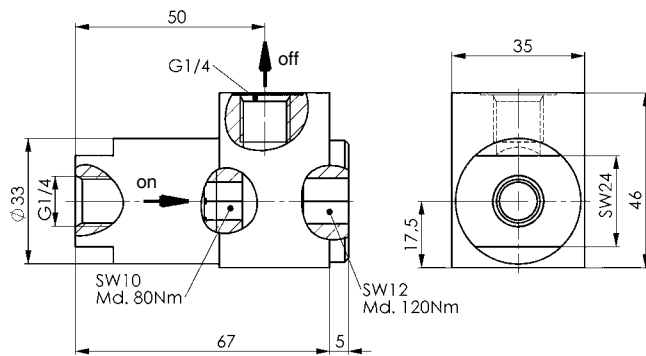
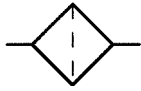

Order no.	Article no.	Filtration [µm]	Weight [g]
323626	6981E-10-G1/4	10	540
323642	6981E-25-G1/4	25	540
323667	6981E-40-G1/4	40	540

Design:

Body made of steel, zinc-plated. Filter insert of aluminium. Filter material of pleated metal fibre felt.

Application:

The Filters are used as an additional safety in order to protect the hydraulic components in the oil circuit. The filter can be located direct in pipes, in front of distributors or in fittings.

For example:

- 10 µm input Intensifier
- 25 µm input valves
- 40 µm input pump units or hydraulic cylinder.

Note:

The smaller the filtration is chosen, as bigger the flow resistance will be. The degree of pollution shall be checked. Due to the design of the housing the exchange of the filter insert is simple. The direction of oil flow has to be considered. Any built in position possible.

Threaded filter set spare parts

Order no.	Designation	Filtration [µm]	Weight [g]
323683	Filter cartridge	10	12,5
323709	Filter cartridge	25	12,5
323725	Filter cartridge	40	12,5

Flow diagram

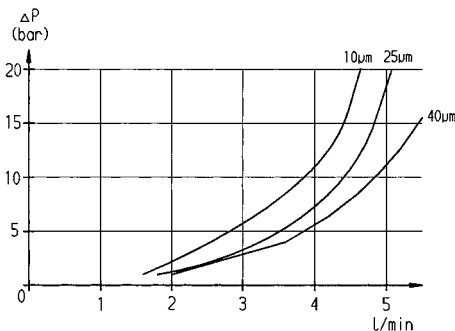

Application example

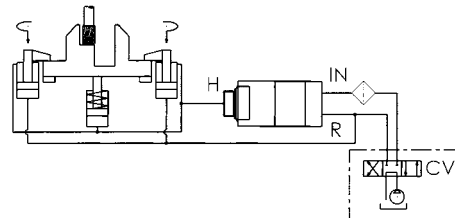

Subject to technical alterations.

No. 6981G-xx-G1/4

Filter with rectifier circuit

max. operating pressure 400 bar.

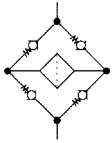

Order no.	Article no.	Filtration [µm]	Weight [g]
321901	6981G-10-G1/4	10	1510
321927	6981G-25-G1/4	25	1510
321968	6981G-40-G1/4	40	1510

Design:

Body from zinc-plated steel. Filter insert from aluminium. Filter material from pleated metal fibre.

Application:

The filters are employed as additional and safety filters for protecting hydraulic components in the oil circuit. They can be used as a pipeline or mounted element with O-ring connection. The flow through these filters is always from outside to inside, regardless of whether they are in the flow or return circuit. This prevents the whirl-up of dirt particles on the filter element.

Note:

The finer the filter, the greater the flow resistance. The degree of clogging must be checked and the filter elements replaced at regular intervals. The large threaded plug on the side must be removed to replace the filter element. The filter element can then be removed. The overall unit can be installed in any position!

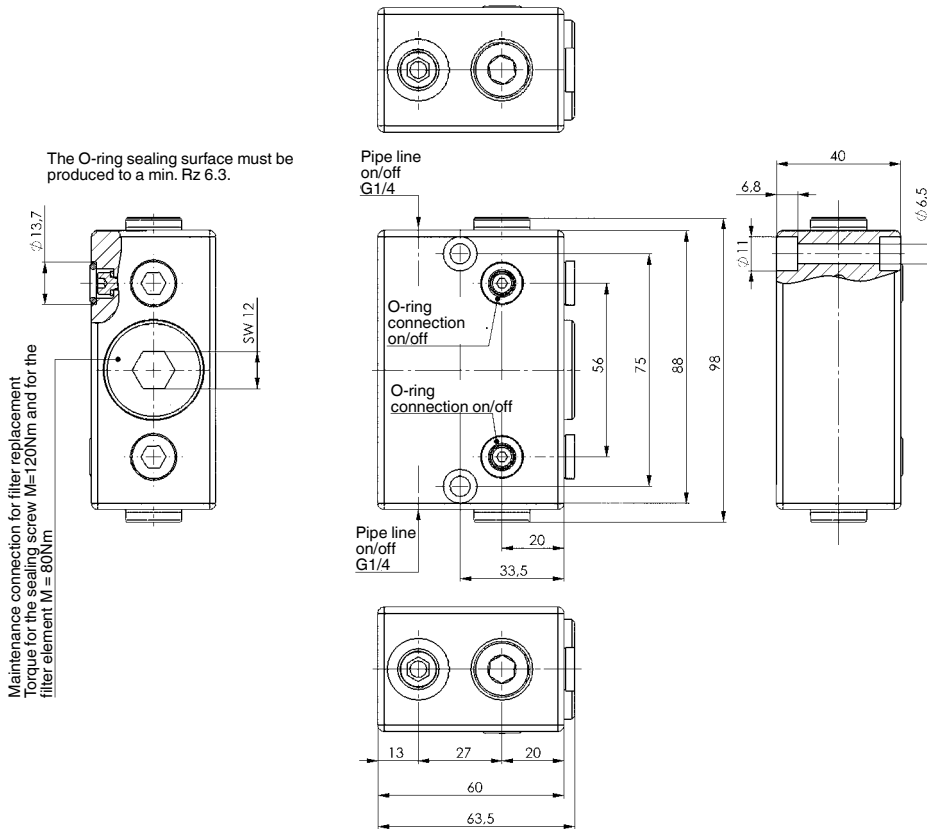

Threaded filter set spare parts

Order no.	Designation	Filtration [µm]	Weight [g]
323683	Filter cartridge	10	12,5
323709	Filter cartridge	25	12,5
323725	Filter cartridge	40	12,5

Hydraulic diagram:

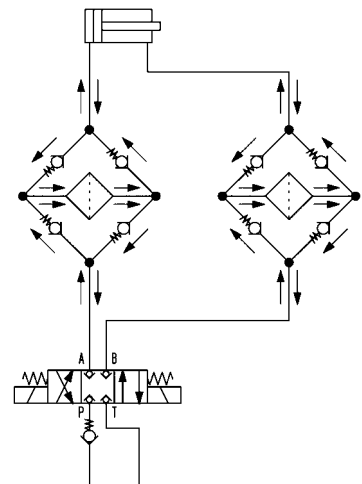

No. 6984-30

Support control, pneumatic

max. operating pressure 10 bar.

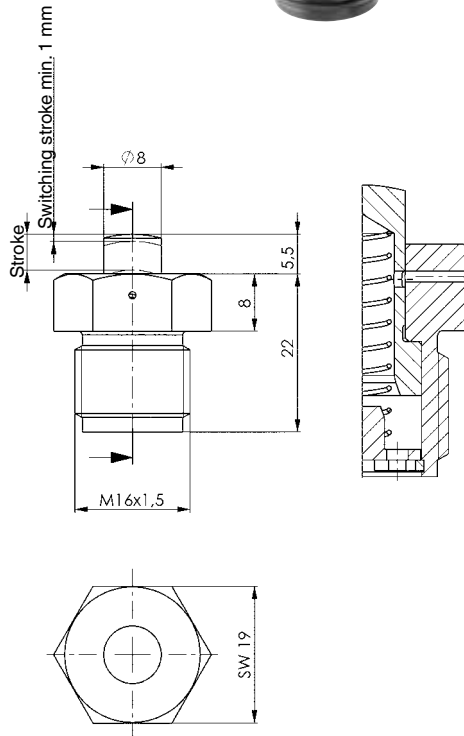
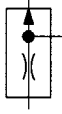

Order no.	Article no.	Stroke max. [mm]	Spring force min. [N]	Spring force max. [N]	Weight [g]
325217	6984-30	5	1,9	2,6	36

Design:

Housing from hardened and burnished steel. Pistons are tempered, nitrided and ground. Compression spring from stainless steel.

Application:

The support control is used in fixtures where a signal indicating a correctly supported workpiece is required to enable machining. Lightweight workpieces should be clamped before being pressurised with compressed air.

Features:

The support control works like a pneumatic back-pressure nozzle. The position is extended from its initial position by a pressure spring. Once applied, the air jet flows through the hollow piston and the radial discharge hole on the support control housing to outside. The discharge hole is sealed as soon as a workpiece is mounted and the piston is pushed downwards by min. 1 mm. The air flow backs up, the internal air pressure rises. The pressure value must be transferred to the control by an appropriate pressure signal converter. The system is relatively insensitive to fine chips.

Note:

The pressure signal converter is not included in the supply scope.

Effective piston surface with closed nozzle = 0.95 cm²

Piston force = piston surface x air pressure + spring force

Installation drawing:

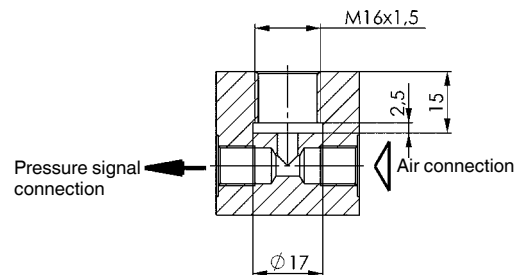

No. 6985 High Pressure Hose

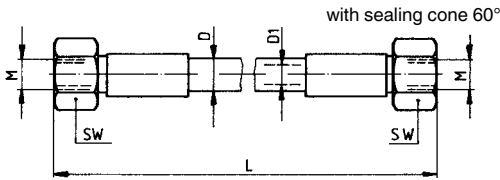

Synthetic internal rubber
2 woven steel-wire inserts



Order no.	Article no.	Test pressure [bar]	Operating pressure [bar]	dia. D [mm]	dia. D1 [mm]	L [mm]	M	SW [mm]	Weight [g]
174177	6985-300	1000	400	15	6	300	M12x1,5	17	100
68510	6985-500	1000	400	15	6	500	M12x1,5	17	300
68528	6985-800	1000	400	15	6	800	M12x1,5	17	405
68536	6895-1250	1000	400	15	6	1250	M12x1,5	17	570
68544	6985-2000	1000	400	15	6	2000	M12x1,5	17	855

Bending radius = min. 100 mm

Design:

Steel fittings, galvanized and passivated.

Note:

This high pressure hose is especially selected for clamping on machine tools. It contains two steelwire reinforcements which guarantee that there is no loss of oil even if the external rubber is damaged. The period of use of a hydraulic hose, including any storage period should not exceed six years. The serviceability must be assessed to fixed inspection criteria. See DIN 20066, Part 5 for further details.

No. 6985K High Pressure Hose with steel-wire interlace

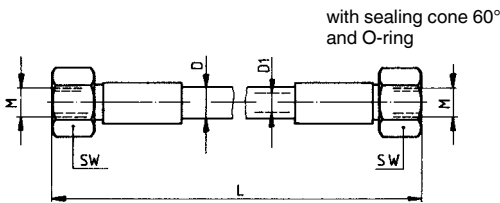

Polyamide
Polyester mesh

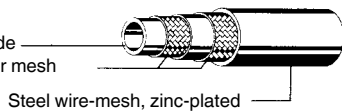

Order no.	Article no.	Test pressure [bar]	Operating pressure dynamic at +50 °C [bar]	dia. D [mm]	dia. D1 [mm]	L [mm]	M	SW [mm]	Weight [g]
68551	6985K-300	960	400	9,4	4	300	M16x1,5	19	100
68569	6985K-500	960	400	9,4	4	500	M16x1,5	19	300
68577	6985K-800	960	400	9,4	4	800	M16x1,5	19	400
68585	6985K-1250	960	400	9,4	4	1250	M16x1,5	19	570
68593	6985K-2000	960	400	9,4	4	2000	M16x1,5	19	850
68601	6985K-3000	960	400	9,4	4	3000	M16x1,5	19	1200

Bending radius = min. 40 mm

Design:

Steel fittings, galvanized and passivated. Hose of synthetic material with steel-wire braid galvanized.

Application:

Insert hose and tighten with 1/4 turn maximum.

Note:

We recommend to use the 3 m long high pressure hose only for double-acting elements. Suits to pipe connections No. 6994. The period of use of a hydraulic hose, including any storage period should not exceed six years. The serviceability must be assessed to fixed inspection criteria. See DIN 20066, Part 5 for further details.

No. 6985R High Pressure Hose

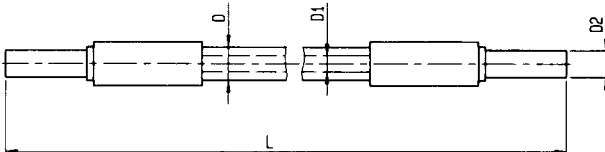

Polyamide

ST wire, brass

Polyurethan

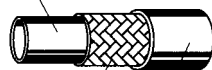

Order no.	Article no.	Test pressure [bar]	Operating pressure dynamic at +50 °C [bar]	dia. D [mm]	dia. D1 [mm]	dia. D2 [mm]	L [mm]	Weight [g]
63198	6985R-300	750	375	9,8	4,8	8	300	65
63206	6985R-500	750	375	9,8	4,8	8	500	90
63214	6985R-800	750	375	9,8	4,8	8	800	120
63222	6985R-1250	750	375	9,8	4,8	8	1250	180
63230	6985R-2000	750	375	9,8	4,8	8	2000	265
63248	6985R-3000	750	375	9,8	4,8	8	3000	380

Bending radius = min. 30 mm

Design:

Steel fitting, galvanized and passivated. Hose of synthetic material with high tensile brass steel-wire braid.

Application:

Insert hose and tighten with 1/4 turn maximum.

Note:

We recommend to use the high pressure hose of 3 m long only for double-acting elements. The period of use of a hydraulic hose, including any storage period should not exceed six years. The serviceability must be assessed to fixed inspection criteria. See DIN 20066, Part 5 for further details.

Hose Fittings

max. operating pressure 400 bar.

Sealing:

Acc. DIN 3852 form D by means of sealing ring
DIN 7603 Form A and 60° sealing cone.

Order no.	Article no.	R	L	L1	E	M	D	SW	D1	Weight [g]
69302	6993-M12x1,5-G1/8	G1/8	24	8	-	-	-	14	-	15
69328	6993-M12x1,5-G1/4	G1/4	30	12	-	-	-	19	-	30
69344	6993-M12x1,5	Dimensions see drawing								15
69609	6996-G1/4-M12x1,5	G1/4	26	12	12	M12x1,5	4	19	-	30
69625	6996-G1/4-G1/8	G1/4	31	8	17	G1/8	3	19	-	38
69641	6996-G1/4-G1/4-35	G1/4	35	12	17	G1/4	4	19	-	44
160093	6996-G1/4-G1/4-59	G1/4	59	12	13	G1/4	4	19	-	100
153288	6996-M16/M12x1,5	M16x1,5	41	11	11	M12x1,5	4	22	-	85
69666	6997-G1/4-1/4NPT	Dimensions see drawing								38
69393	908-G1/8	G1/8	8	3	-	-	14	5	-	6
69419	908-G1/4	G1/4	12	3	-	-	18	6	-	13
176701	908-G3/8*	G3/8	12	5	-	-	24	8	-	22
179952	908-M16x1,5*	M16x1,5	12	5	-	-	22	8	-	24
176693	908G-G1/8*	G1/8	8	4	-	-	14	5	-	7
176719	908G-G1/4*	G1/4	12	5	-	-	19	6	-	17
326389	908S-G1/8*	G1/8	8	4	-	-	14	5	-	6
343632	908S-G1/4*	G1/4	12	5	-	-	19	6	-	17
69815	7603-Form A-G1/8	-	1,0	-	-	-	13,5	-	10,0	0,5
69823	7603-Form A-G1/4	-	1,5	-	-	-	18,0	-	13,5	1,0

* With integrated rubber sealing

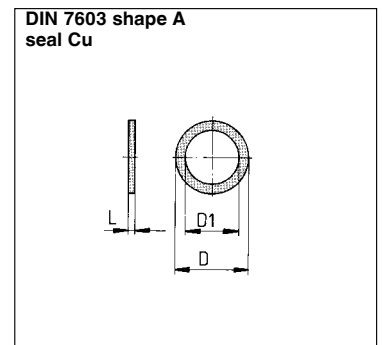
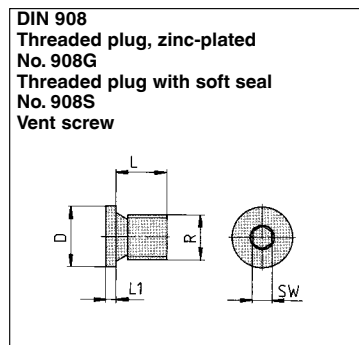
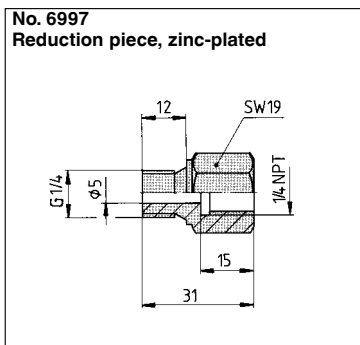
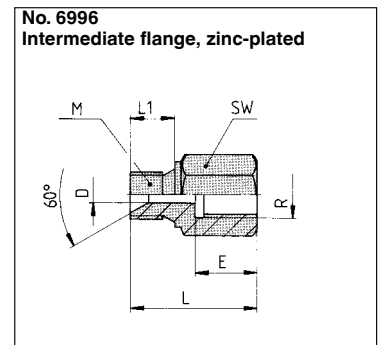
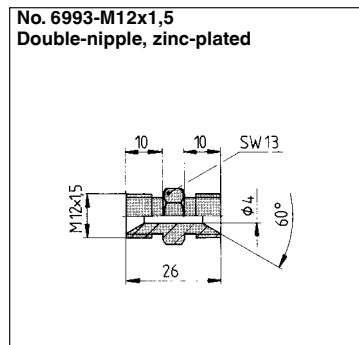
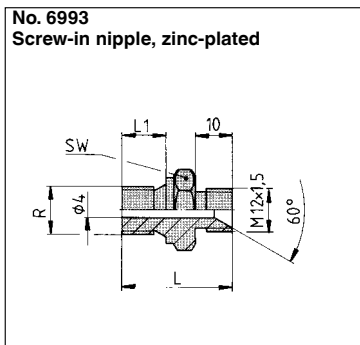

Example of assembly:

- 1) Hollow-rod cylinder no. 6920
- 2) Seal DIN 7603A
- 3) Screw-in nipple no. 6993
- 4) High-pressure hose no. 6985
- 5) Connector no. 6990-G1/4S
- 6) Sleeve no. 6990-G1/4M



No. 6994

Tube Fittings, heavy-duty

for steel tubes with outer diameter 8 mm and internal diameter 4 mm, with olive ring, max. operating pressure 630 bar.

No. 6994-01
Straight screw-in flange

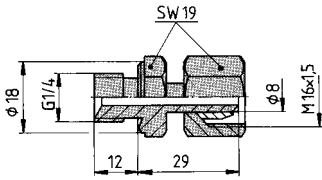

No. 6994-02
Straight screw-on fitting

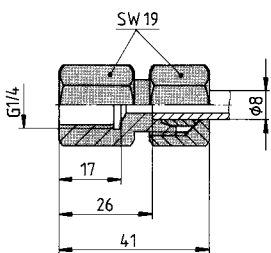

No. 6994-06
Angular fitting

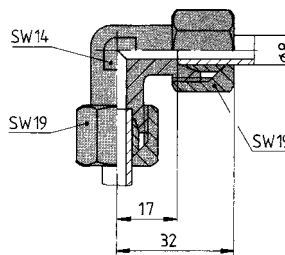

No. 6994-03 und Nr. 6994-12
Angular swivelling screw fitting

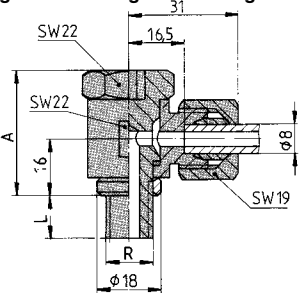

No. 6994-07
Adjustable angular fitting

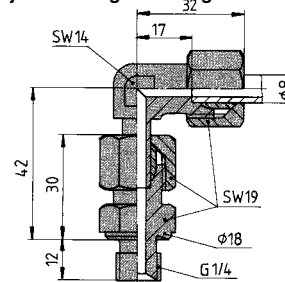

No. 6994-10
Adjustable T-bolt fitting

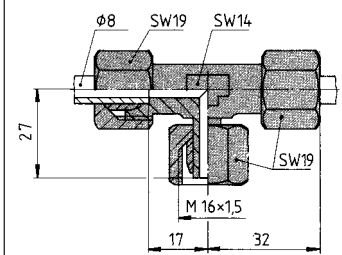

No. 6994-04 und Nr. 6994-13
T-swivelling bolt fitting

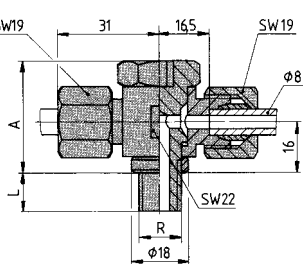

No. 6994-08
T-bolt fitting

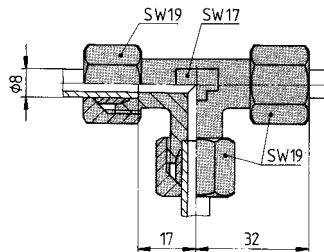

No. 6994-14
Straight wall fitting

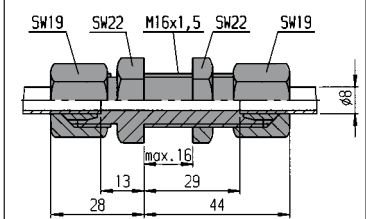

No. 6994-05 und Nr. 6994-11
Straight screw-in fitting

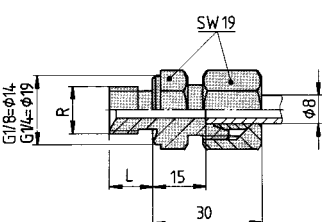

No. 6994-09
Cross-pattern bolting

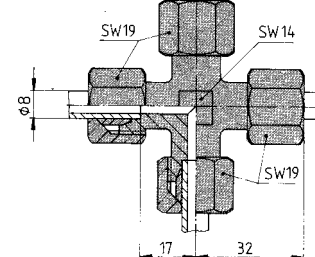

No. 6994-17
Union nut with cutting ring

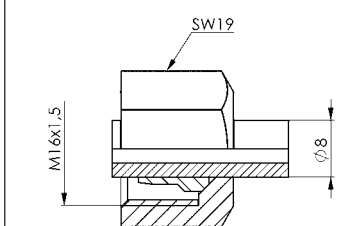

Order no.	Article no.	A	L	R	Weight [g]
160184	6994-01	Dimensions see drawing			50
160192	6994-02	Dimensions see drawing			60
160358	6994-03	34,5	12	G1/4	125
170266	6994-04	34,5	12	G1/4	150
175323	6994-05	-	12	G1/4	55
160366	6994-06	Dimensions see drawing			110
160200	6994-07	Dimensions see drawing			125
170258	6994-08	Dimensions see drawing			155
170308	6994-09	Dimensions see drawing			150
170316	6994-10	Dimensions see drawing			120
112714	6994-11*	-	8	G1/8	55
112961	6994-12*	32,5	8	G1/8	125
116418	6994-13*	32,5	8	G1/8	150
131631	6994-14	Dimensions see drawing			130
184150	6994-17	Dimensions see drawing			23
122903	6994-30	Hydraulic tube, length 2,0 m			600

* max. operating pressure 400 bar; max. permissible torque M = 40 Nm

Sealing:

According to DIN 3852 Form B by means of sealing edge or sealing edge ring and cutting ring. Attention: Do not use teflon tape!

Note to no. 6994-30:

Seamless hydraulic tube, phosphatized and oiled, diameter 8x2 mm, made of steel, according to DIN 2391 C normalized, annealed seamless cold-drawn. For clamping elements with operating pressure of 500 bar this tube quality is recommended only.

No. 6994

Tube fittings, light duty

for steel tubes with outer diameter 6 mm and internal diameter 3 mm, with olive ring, max. operating pressure 315 bar.

Order no.	Article no.	A	L	R	Weight [g]
320689	6994-010	Dimensions see drawing			25
320705	6994-030	21	8	G1/8	74
320721	6994-040	21	8	G1/8	85
320747	6994-050	-	8	G1/8	25
320762	6994-060	Dimensions see drawing			51
320788	6994-080	Dimensions see drawing			71
320804	6994-090	Dimensions see drawing			77
320820	6994-140	Dimensions see drawing			67
320846	6994-150	Dimensions see drawing			42
313361	6994-170	Dimensions see drawing			12
320861	6994-25	Hydraulic tube, length 2,0 m			335

Sealing:

In accordance with DIN 3852 shape B by sealing edge or by sealing edge ring and olive ring.
Caution! Do not use teflon tape!

Note to no. 6994-25:

Seamless hydraulic tube, phosphatized and oiled, dia. 6 x 1.5 mm, length 2.0 m, fully killed steel in accordance with DIN 2391 C, normalized, bright-annealed (NBK), cold-drawn. For clamping elements up to 315 bar operating pressure this pipe quality is exclusively recommended.

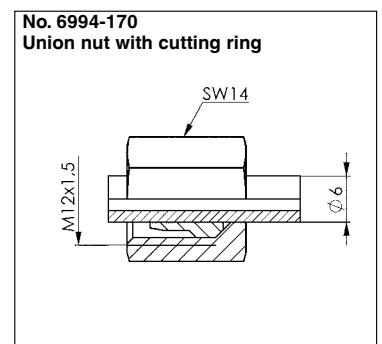
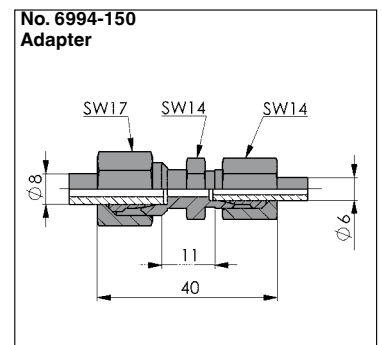
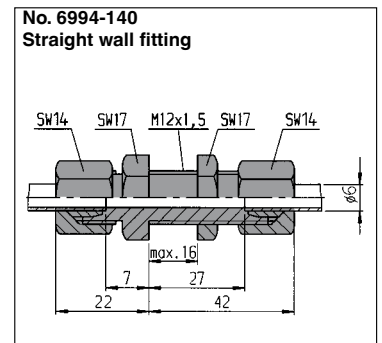
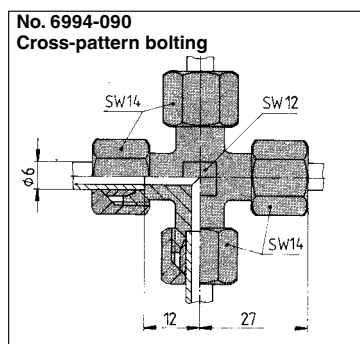
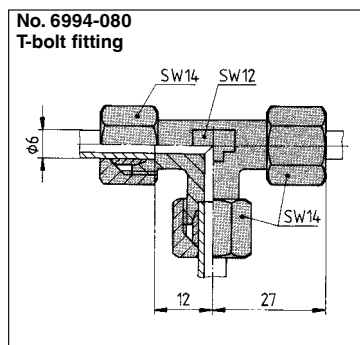
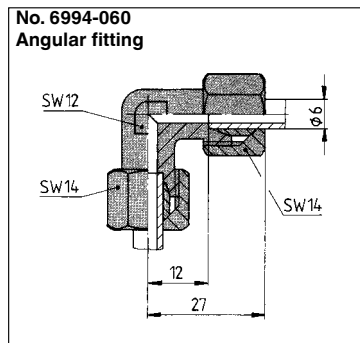
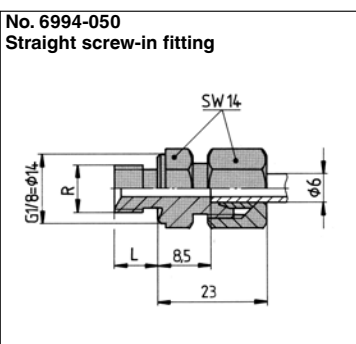
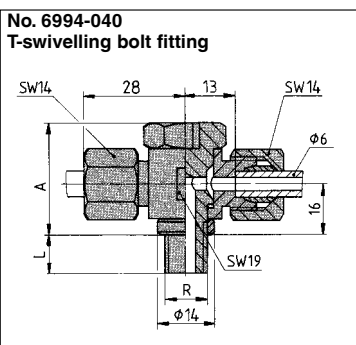
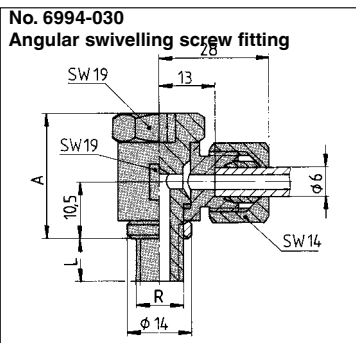
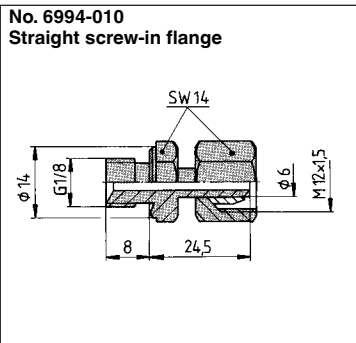

No. 6940

Set screw, ball-shaped

Strength class 10.9

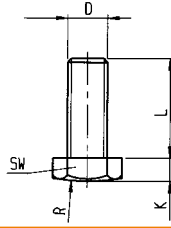

Order no.	Article no.	D x L	K	R	SW	Weight [g]
64014	6940-M5	M5x10	3,5	25	8	2,4
64022	6940-M6	M6x12	4,0	30	10	4,3
64030	6940-M8	M8x16	5,3	40	13	9,9
64048	6940-M10	M10x20	6,4	50	17	21,3
64055	6940-M12	M12x30	7,0	60	19	36,4
64063	6940-M16	M16x40	10,0	75	24	85,8
64071	6940-M20	M20x50	12,5	100	30	168

No. 7110DM-**xM**

Set screw

ball-shaped, brass, with steel nut

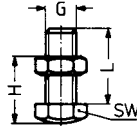

Order no.	Article no.	G x L	H	SW	Weight [g]
77743	7110DM-12xM12	M12x30	16-28	19	50
77750	7110DM-16xM16	M16x40	20-38	24	100

No. 7110DF-**xM**

Set screw

with flat-faced ball, ribbed.

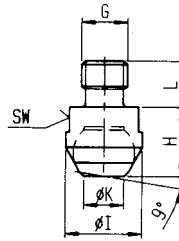

Order no.	Article no.	G x L	H	dia. I	dia. K	SW	Weight [g]
86637	7110DF-12xM12	M12x12	18	20	10,5	17	43
86652	7110DF-16xM16	M16x16	27	30	20,0	27	149
86223	7110DF-20xM20	M20x20	35	50	34,5	41	520

No. 7110DK-**xM**

Set screw

with flat-faced ball

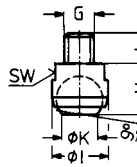

Order no.	Article no.	G x L	H	dia. I	dia. K	SW	Weight [g]
77446	7110DK-12xM12	M12x12	18	20	10,5	17	43
77453	7110DK-16xM16	M16x16	27	30	20,0	27	149
76059	7110DK-20xM20	M20x20	35	50	34,5	41	520

No. 7110DH-**xM**

Set screw

with flat-faced ball, ribbed, adjustable.

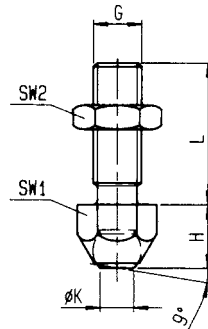

Order no.	Article no.	G x L	H	dia. K	SW1	SW2	Weight [g]
87916	7110DH-10xM10	M10x30	15,7	8,6	17	17	55
87858	7110DH-12xM12	M12x35	15,7	8,6	17	19	55
87874	7110DH-16xM16	M16x40	20,7	10,5	24	24	115
83931	7110DH-20xM20	M20x50	27,3	20,0	30	30	230

No. 7110DI-**xM**

Set screw

with flat-faced ball, adjustable, plain.

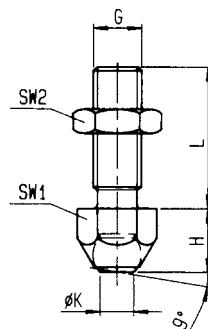

Order no.	Article no.	G x L	H	dia. K	SW1	SW2	Weight [g]
87908	7110DI-8xM8	M8x25	11,6	5,5	13	13	25
87924	7110DI-10xM10	M10x30	15,7	8,6	17	17	55
87866	7110DI-12xM12	M12x35	15,7	8,6	17	19	55
87882	7110DI-16xM16	M16x40	20,7	10,5	24	24	115
83949	7110DI-20xM20	M20x50	27,3	20,0	30	30	230

No. 6383ZUK
Centering tensioner
 with flat-faced ball.
 Repeatability ± 0.025 mm
 Rotational accuracy $\pm 0,025$ mm

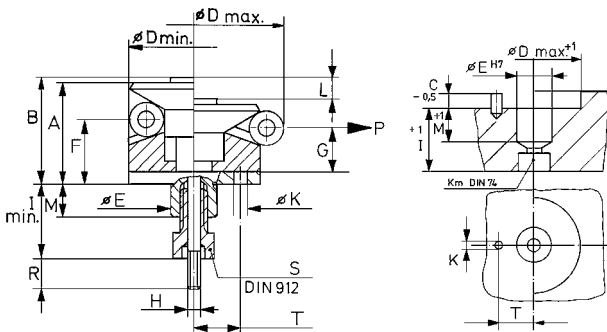

Order no.	D min.	D max.	max. pull force [kN]	S DIN912	P [kN]	Weight [g]
373563	11,7	14,2	2,3	M6x10	2,0	9
373571	14,5	18,5	2,3	M6x10	2,0	22
373589	18,5	22,5	4,0	M8x16	3,5	54
373597	22,5	26,5	6,5	M10x16	6,0	64
373605	26,5	30,5	6,5	M10x16	6,0	98
373613	30,5	38,5	9,0	M12x20	8,5	139
373621	38,5	46,5	9,0	M12x20	8,5	248
373639	46,5	54,5	9,0	M12x20	8,5	338
373647	54,5	70,5	17,0	M16x20	16,0	660
373654	70,5	86,5	17,0	M16x20	16,0	1252
373662	86,5	102,5	17,0	M16x20	16,0	1765

Application:

For central positioning and clamping in blind holes where slight ball impressions are acceptable. Operation from below, automated or manual.

Note:

For deep installation, clearance D max. must be provided. Assembly tools: Hole K for retaining pin for determining the precise position of the balls.

Dimensions

Order no.	A	B	C	E f7	F	G	H	I min.	K	L	M	R	T
373563	11,9	15,0	1,0	8	9,2	8,6	M3	19,5	1,5	1,5	7,5	10	5,2
373571	12,1	17,0	1,5	8	9,1	7,9	M3	19,5	2,0	2,3	7,5	10	6,0
373589	16,1	20,6	1,5	12	11,6	10,4	M4	28,0	2,5	2,3	11,5	16	7,5
373597	20,1	27,1	2,0	15	15,1	13,9	M5	30,0	3,0	2,3	11,5	14	9,4
373605	20,1	27,1	2,0	15	15,1	13,9	M5	30,0	3,0	2,3	11,5	14	10,5
373613	24,2	32,7	2,0	20	15,2	12,8	M6	36,0	4,0	4,6	15,5	16	12,5
373621	27,1	35,6	2,5	20	18,1	15,7	M6	36,0	4,0	4,6	15,5	16	12,5
373639	27,1	35,6	2,5	20	18,1	15,7	M6	36,0	4,0	4,6	15,5	16	12,5
373647	40,7	50,2	2,5	30	23,7	19,0	M8	43,0	5,0	9,3	16,5	16	20,0
373654	45,6	55,1	2,5	40	28,3	23,6	M8	43,0	5,0	9,3	16,5	16	25,0
373662	45,6	55,1	2,5	60	28,3	23,6	M8	43,0	5,0	9,3	16,5	16	36,5

No. 6383ZUS
Centering tensioner
 With protective segments.
 Repeatability ± 0.025 mm
 Rotational accuracy $\pm 0,025$ mm

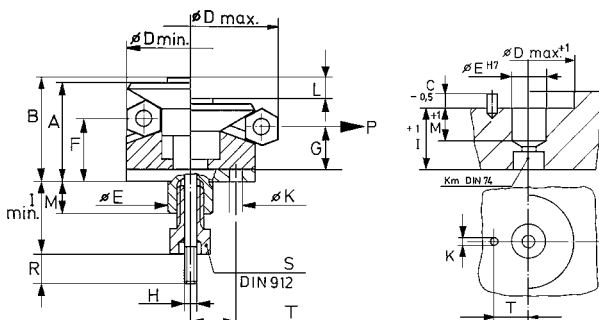

Order no.	D min.	D max.	max. pull force [kN]	S DIN912	P [kN]	Weight [g]
373670	14,5	18,5	2,3	M6x10	2,0	22
373688	18,5	22,5	4,0	M8x16	3,5	54
373696	22,5	26,5	6,5	M10x16	6,0	64
373704	26,5	30,5	6,5	M10x16	6,0	98
373712	30,5	38,5	9,0	M12x20	8,5	139
373720	38,5	46,5	9,0	M12x20	8,5	248
373738	46,5	54,5	9,0	M12x20	8,5	338
373746	54,5	70,5	17,0	M16x20	16,0	660
373753	70,5	86,5	17,0	M16x20	16,0	1252
373761	86,5	102,5	17,0	M16x20	16,0	1765

Application:

For unmarred surfaces with central positioning and clamping in blind holes. Operation from below, automated or manual.

Note:

For deep installation, clearance D max. must be provided. Assembly tools: Hole K for retaining pin for determining the precise position of the segments.

Dimensions

Order no.	A	B	C	E f7	F	G	H	I min.	K	L	M	R	T
373670	14,1	17,0	1,5	8	9,1	7,9	M3	19,5	2,0	2,3	7,5	10	6,0
373688	16,1	20,6	1,5	12	11,6	10,4	M4	28,0	2,5	2,3	11,5	16	7,8
373696	20,1	27,1	2,0	15	15,1	13,9	M5	30,0	3,0	2,3	11,5	14	9,4
373704	20,1	27,1	2,0	15	15,1	13,9	M5	30,0	3,0	2,3	11,5	14	10,5
373712	24,2	32,7	2,0	20	15,2	12,8	M6	36,0	4,0	4,6	15,5	16	12,5
373720	27,1	35,6	2,5	20	18,1	15,7	M6	36,0	4,0	4,6	15,5	16	12,5
373738	27,1	35,6	2,5	20	18,1	15,7	M6	36,0	4,0	4,6	15,5	16	12,5
373746	40,7	50,2	2,5	30	23,7	19,0	M8	43,0	5,0	9,3	16,5	16	20,0
373753	45,6	55,1	2,5	40	28,3	23,6	M8	43,0	5,0	9,3	16,5	16	25,0
373761	45,6	55,1	2,5	60	28,3	23,6	M8	43,0	5,0	9,3	16,5	16	36,5

Subject to technical alterations.

THE FIRST STEP FOR USE AND EMPLOYMENT OF SIDE THRUST PIECES:

- > What is being positioned or clamped?
- > Which side thrust pieces will be used?
- > What size corresponds to the workpiece?
- > What tolerance does the workpiece have?
- > How large is the dimension Y? (Workpiece height)
- > How large is the dimension X? (See table)
- > Should the spring deflection be completely used?
- > How is the coordinate dimension determined?

EXAMPLE: POSITIONING OR CLAMPING A PLATE 100 X 50 X 8 MM

Should the pin diameter be 5, 6 or 8 mm?

- > If nothing may extend over the plate 5 mm
- > If projection would not be a problem 6 or 8 mm
- > If clamping will be done additionally 6 mm
- > If drilling will be performed without additional clamping 8 mm

Length / width of the workpiece?

- > Length = $100 +0/-0,4$ = medium dimensio 99,8 mm
- > Width = $50 +0,2/-0,2$ = medium dimensio 50,0 mm

Workpiece height Y?

The tolerance can be ignored

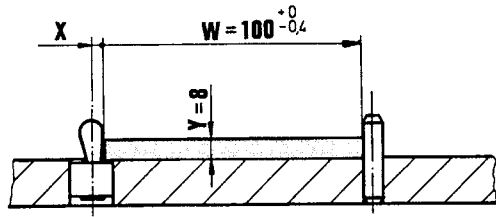

W= workpiece (+/- tolerance)
 -F = pre-tension
 F = (-F) + (+F)

What force should be selected?

- > For positioning tasks 30 - 60 N
- > For clamping forces 90 - 150 N

Dimension X for side thrust pieces with plastic spring?

- > See table or formula below
- Size 05 X = 1,6 mm
- Size 06 X = 1,9 mm
- Size 08 X = 2,7 mm

Dimension X for side thrust pieces with steel spring?

- > See table or formula below
- > Note that F is larger and thus allows greater leeway

Y = workpiece height
 +F = clamping force (spring deflection for tolerance)
 T = tolerance

FORMULAS:

For workpieces that are higher than C minus r, the table values for dimension X or the formula $X = B/2 - (-F)$ apply.

For workpieces that are smaller than C minus r, the table values for dimension X or the formula $X = B/2 - (-F) - [(C - r - Y) \times 0,123]$ apply.

Formula for coordinates:

$$K = W - T/2 + x + S/2$$

The table values are standard values that should ideally be checked using a sample clamping.

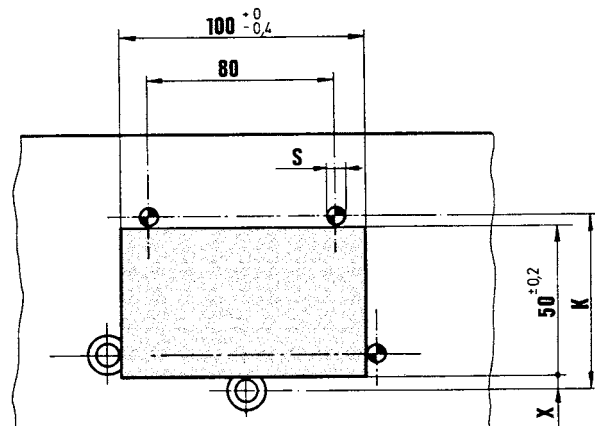
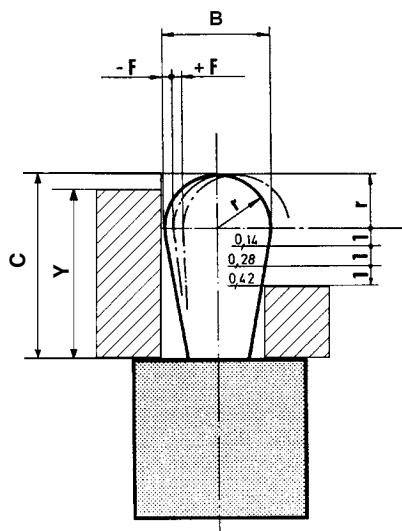

No. 6380

Lateral pressure pad

without seal.
Steel pin for clamping.

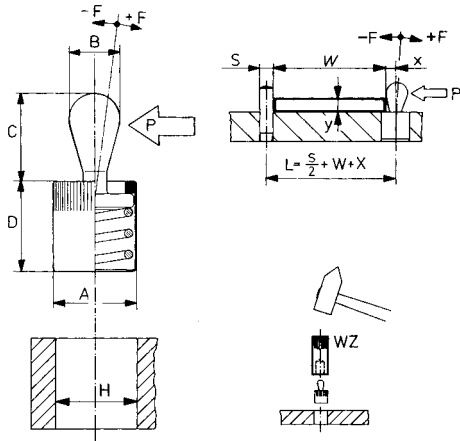

Order no.	A	B	C	D-1	H H8	F	~P [N]	X	Suitable tool	Weight [g]
373001	6	3	4,0	7	6	±0,5	10	0,9	03	0,6
373019	6	3	4,0	7	6	±0,5	20	0,9	03	0,6
373027	6	3	4,0	7	6	±0,5	40	0,9	03	0,7
373035	10	5	6,7	11	10	±0,8	20	1,6	05	2,6
373043	10	5	6,7	11	10	±0,8	50	1,6	05	2,9
373050	10	5	6,7	11	10	±0,8	100	1,6	05	3,1
373068	10	6	10,7	11	10	±1,0	40	1,8	06	3,6
373076	10	6	10,7	11	10	±1,0	75	1,8	06	3,6
373084	10	6	10,7	11	10	±1,0	150	1,8	06	3,9
373092	12	8	13,9	13	12	±1,3	50	2,6	08	7,0
373100	12	8	13,9	13	12	±1,3	100	2,6	08	7,2
373118	12	8	13,9	13	12	±1,3	200	2,6	08	7,4
373126	16	10	16,7	17	16	±1,6	100	3,2	10	15,0
373134	16	10	16,7	17	16	±1,6	200	3,2	10	15,4
373142	16	10	16,7	17	16	±1,6	300	3,2	10	15,8

Note:

Without sealing for operations without dirt, temperature-resistant up to 250°C.
Installation by pressing in.

No. 6380D

Lateral pressure pad

with seal against chips and dirt.
Steel pin for clamping.

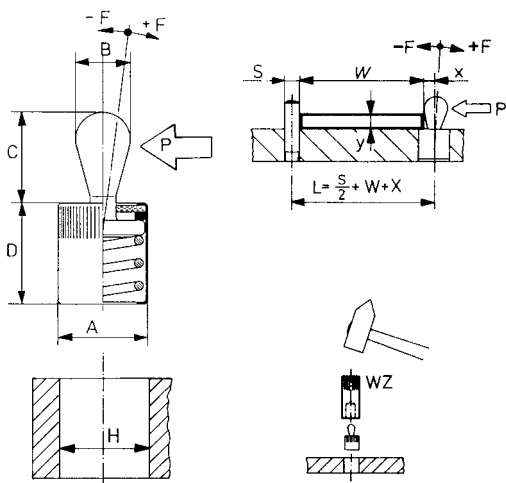

Order no.	A	B	C	D-1	H H8	F	~P [N]	X	Suitable tool	Weight [g]
373159	6	3	4	7	6	±0,5	10	0,9	03	0,6
373167	6	3	4	7	6	±0,5	20	0,9	03	0,6
373175	6	3	4	7	6	±0,5	40	0,9	03	0,7
373183	10	5	6	12	10	±0,8	20	1,6	05	2,7
373191	10	5	6	12	10	±0,8	50	1,6	05	2,9
373209	10	5	6	12	10	±0,8	100	1,6	05	2,9
373217	10	6	10	12	10	±1,0	40	1,8	06	3,1
373225	10	6	10	12	10	±1,0	75	1,8	06	3,6
373233	10	6	10	12	10	±1,0	150	1,8	06	3,7
373241	12	8	13	14	12	±1,3	50	2,6	08	3,9
373258	12	8	13	14	12	±1,3	100	2,6	08	7,1
373266	12	8	13	14	12	±1,3	200	2,6	08	7,3
373274	16	10	16	18	16	±1,6	100	3,2	10	7,6
373282	16	10	16	18	16	±1,6	200	3,2	10	15
373290	16	10	16	18	16	±1,6	300	3,2	10	15,4

Note:

With sealing for chip-producing operations with dirt, temperature-resistant up to 150°C. Sealing: CR, black, 60 Shore. Installation by pressing in.

No. 6380WZ

Tool

for pressing in the lateral pressure pad.



Order no.	Size	Weight [g]
373308	03	15,9
373316	05	18,8
373332	08	64,3
373340	10	105,3

No. 6387

Eccentric clamping bolt

clamp in x-y direction with pull down effect.
Hardened steel (56±1 HRC)



Order no.	A	B	C	D	E	F	G	SW	X	Z	max. holding force [kN]	max. torque [Nm]	Weight [g]
373779	11,0	M4	4,0	12	2,6	4,8	5,5	3	4,0	5,0	0,5	5	5
373787	15,6	M6	5,5	16	5,0	6,7	7,8	5	5,9	7,0	2,5	20	10
373795	19,1	M8	6,5	20	5,8	8,3	9,6	6	7,1	8,6	3,5	30	15
373803	23,7	M10	8,0	24	6,3	9,8	11,8	8	8,5	10,3	5,0	45	20
373811	27,3	M12	9,0	18	8,5	11,7	13,6	10	10,1	12,2	7,0	65	35
373829	27,3	M12	9,0	30	8,5	11,7	13,6	10	10,1	12,2	5,5	50	55
373837	35,4	M16	12,0	24	10,7	15,6	17,7	14	13,2	16,2	11,0	100	90
373845	35,4	M16	12,0	40	10,7	15,6	17,7	14	13,2	16,2	8,5	80	110

Application:

- Clamping above the machining surface
- Clamping below the machining surface
- Clamping in holes

Advantage:

- stepless adjustment with eccentric
- high wear resistance

On request:

The eccentric clamping bolt is also with available with left-hand thread on request.

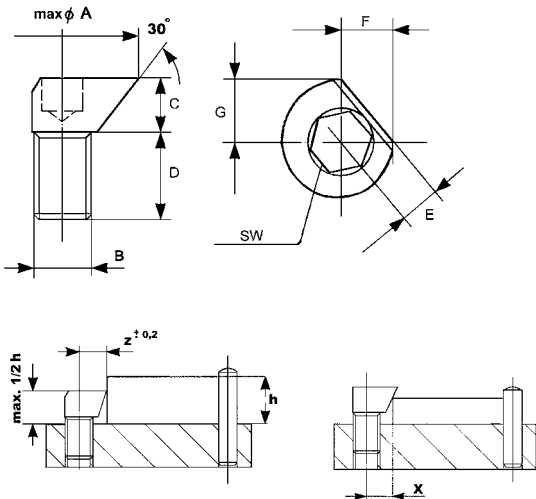

Clamping above the machining surface



Clamping below the machining surface



NO. 6906P

> Pressure generators



NO. 6906PB**

> Pressure-generator accessories



NO. 6945-22-20

> Clamping bars



NO. 6945-22

> Spacer bars



NO. 6945-11-**

> Clamping heads



NO. 6946

> Wedge clamp



NO. 6945-28-**

> Clamping-stud holder



NO. 6945-15-10

> Clamping pistons, complete



NO. 6945-02-04

> Clamping stud



THE FOLLOWING SYSTEM ELEMENTS ARE USED TO MEET THE REQUIREMENTS

- > Fixed clamping bars for press table and piston for the clamping of tools with common clamping edge heights and tool-pallet sizes (fig. 4, right-hand side).
- > Clamping heads, sliding in T-groove, for holding tools for the press table and the piston (fig. 5, right-hand side).
- > Hydraulic clamping devices at stud for the clamping of tools equipped with a clamping pin (fig. 6, right-hand side, and 1).
- > Tool pallets (upon request) for tools
- > Fixed pallets for each tool
- > Interchangeable pallets, i.e. one pallet for several tools.
- > Pump unit with 4 or 5 separate clamping circuits.

SAFETY WHEN USING CLAMPING HYDRAULICS

The pump device is equipped with 4 or 5 separate clamping circuits and additional pressure switches in all circuits. In addition, the oil level is monitored by a float switch (fig. 2). Pressure switch and float switch are connected in series in a terminal housing and are routed to the terminal rail of the device controller. Control and safety functions can be integrated into the machine controller via the 13-pin socket of the device controller. In case of a pressure-drop in one or more clamping circuits, or if the oil level is low, the press is shut down automatically. The hydraulic clamping elements are supplied diagonally at the table and at the piston by two independent and pressure-controlled clamping circuits (fig. 3).

FIGURE 1

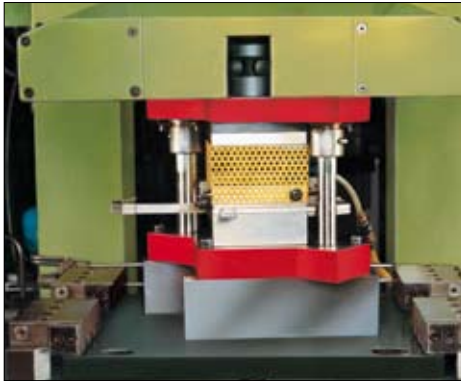

- > Clamping strip on table and stud clamping on plunger

FIGURE 2

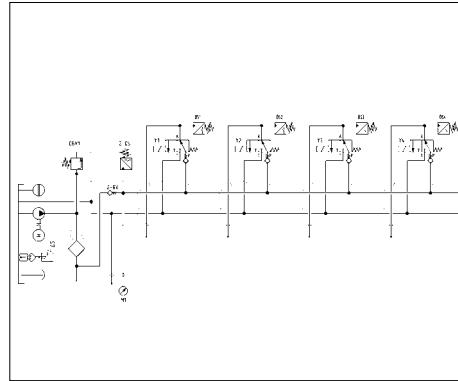

- > Hydraulic diagram pressure generators

FIGURE 3

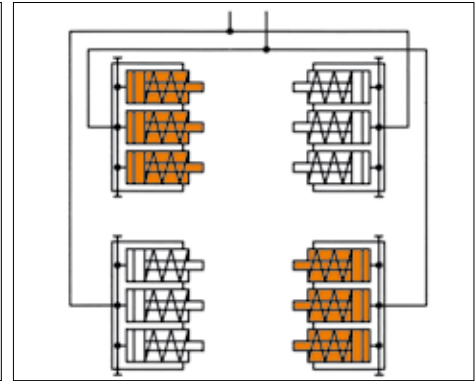

- > Safety circuit

AMF has developed a „Hydraulic tool-clamping system for presses“ which reduces the set-up times of the press to the absolute minimum. The system is designed for „old“ as well as „new“ presses of various manufacturers. This system also takes into account the storage, transport and frequency of use of the tools.

The developments observed in non-cutting operations shows an increasing demand for smaller machining lots, which of course requires a sound economic, cost-effective, basis. Primary machining times and secondary set-up times must be minimized. In several instances, presses have reached their stroke-cycle limits for tools or workpieces. Accordingly, development is now focussed on the minimization of set-up times.

When converting a press to another product, down-times are inevitable for the following reasons:

- > removal of tool
- > installation of new tool
- > adjustment of press to new tool

The set-up of the press is has been reduced to a minimum by CNC control. What remains for optimization is the tool-changing time. This is where you may benefit from our products.

OUR „HYDRAULIC TOOL-CLAMPING SYSTEM FOR PRESSES“ MEETS THE FOLLOWING REQUIREMENTS:

- > Safety is ensured, i.e. tool storage, transport and tool clamping comply with strict requirements.
- > Various press types can be equipped.
- > Solutions are available for already present as well as new press types.
- > Set-up times are significantly reduced.
- > Tool storage is controlled.
- > The removal of tools from the rack, transport and insertion into the press are more efficient, safer and easier for the user.
- > The system can be quickly installed at any press.
- > ... and is suitable for frequently used tools as well as for rarely used tools.

FIGURE 4



> Clamping bar

FIGURE 5



> Clamping head

FIGURE 6



> Clamping-stud holder

No. 6906P

Pump Unit

with 4 separate clamping circuits, single acting
max. operating pressure 400 bar.



Order no.	Article no.	Clamping circuits	Flow rate Q [l/min.]	Valve type	Mode of operation	Weight [Kg]
326702	6906P-64319	4	2,5	4 x 3/2 + DS	remote control	65

Design:

Compact, ready to plug in pump unit, ready for operation electrically and hydraulically. Complete with pressure control unit, electromagnetic valve, manometer, float switch, oil filling. The electrical controller is equipped with main switch, indicator lamps and flange sockets, carrying handle and two-part protective hood. Electrical connection complete with CEKON connector.

Application:

The pump unit is designed to operate hydraulic clamping systems.

Features:

Radial piston pump powered by standard three phase motor with thermal overload protection by means of thermocouples installed in the winding. Each of the 4 clamping circuits is equipped with a 3/2 seat valve. Four pressure switches (DS) are attached externally for the external pressure monitoring. The pressure adjustment is made using a pressure relief valve (DBV). Attention must be paid to the necessary pressure difference of approx. 40 bar between DS and DBV. The pump unit operates intermittently. In the case of a pressure drop, the pump unit is activated automatically by the pressure switch. The clamping pressure is indicated using illuminated push buttons. The installed float switch switches off the pump in the case of low oil level and outputs an optical signal.

Note:

Pay attention to faultless venting during the connection of the elements. Pumping in the case of pressure drop must be made maximum 2x per minute. The unit must not operate continuously. To ensure safe hydraulic tool clamping, clamping at ram and table is carried out in each case by means of a separate clamping circuit. The four pressure switches DS1-DS4 are used to provide external pressure monitoring of the four clamping circuits. The machine is automatically switched off if pressure drops in one clamping circuit or in the case of lack of oil. The electrical connection between press controller and power unit must be performed by the customer.

Hydraulic diagram

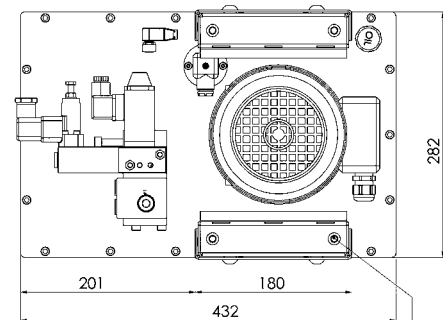
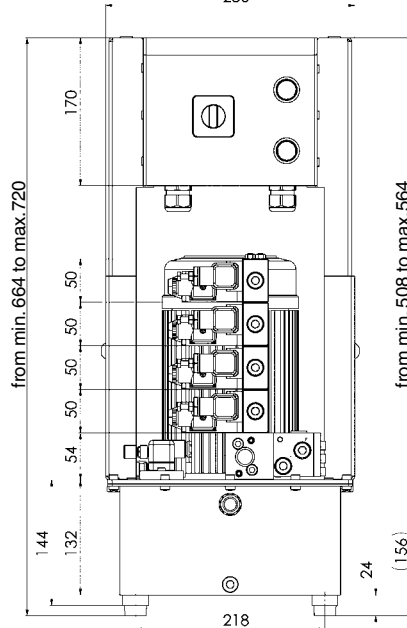
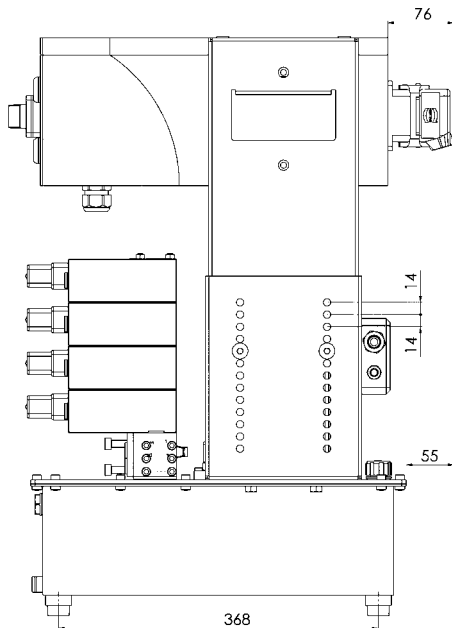
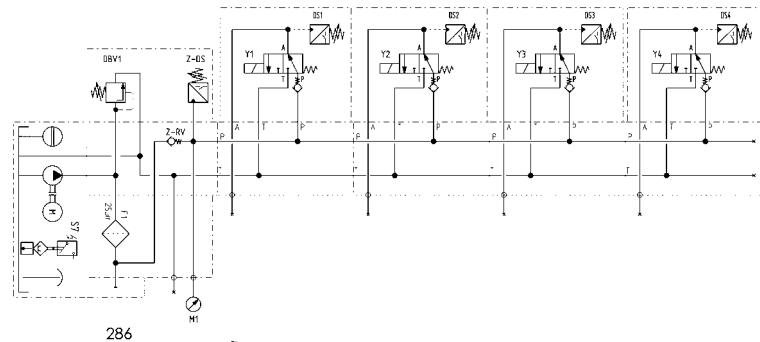

M8 thread for lifting dev

Subject to technical alterations.

Pump Unit No. 6906P

Hydraulic specifications:

Max. operating pressure	400 bar
Min. operating pressure	40 bar
Oil capacity, reservoir	approx. 10 litre
Oil capacity, usable	approx. 4 litre
Oil-flow rate	2,5 l/min.
Valve type	4 x 3/2 seat valve and 4 x Pressure switch for external pressure monitoring
Hydraulic connection	thread G1/4
Noise level	max. 70 dB(A)
Ambient temp. range	-10° C to + 35° C
Position of use	upright
Pump type	Radial-piston pump with 3 pistons
Load cycle	max. 500/h
Hydraulic fluid	Hydraulic oil HLP and HLPD according to DIN 51524 part 2
Oil recommendation	HLP 22 and HLPD 22 or HLP 32 and HLPD 32
Viscosity	ISO VG 22 and 32 DIN 51519

Electric specifications:

Nominal voltage	400 V/50 Hz three-phase
Control voltage	24 V DC
Valve voltage	24 V DC
Motor speed	2900 1/min.
Sense of rotation	any
Motor rating	1,1 kW
Pump motor	Three-phase standard motor
Nominal current	3 A
Fuse, supply line	16 A slow-blow
Fuse, control line	1 A primary, 4 A secondary
Electric connection	Ölflex -100; 5x1,5 mm ² , 3 m long and connector CEE-16 A 6h
Protection class	IP 54
Duty cycle	max. 50% intermittent operation
Operation type	Socket for remote control
Fill-level monitoring	Float switch

Wiring circuit of pump unit with 4 clamping circuits, remote control

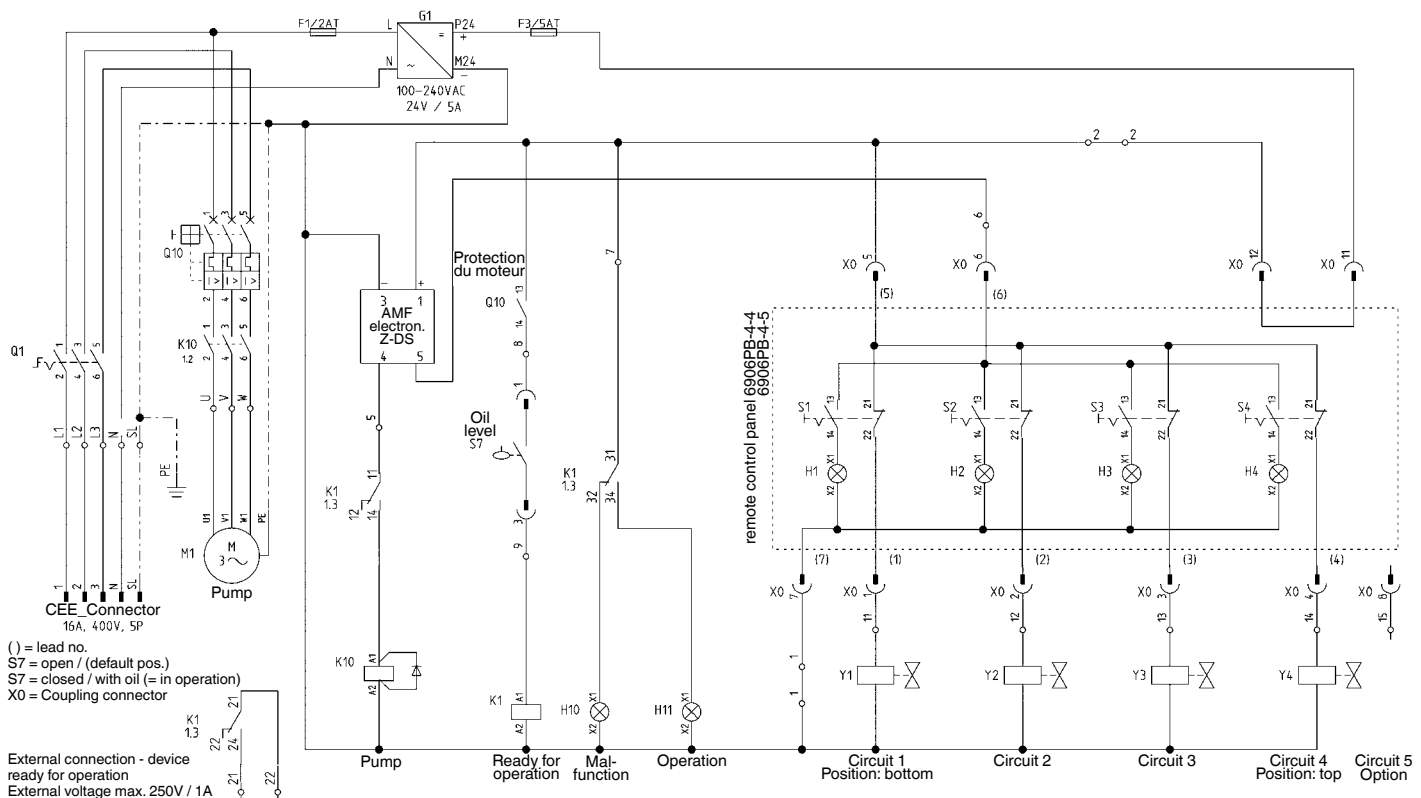

Note: Clamping circuit 1 - 4 = directional seat-valve clamped with power off.

To increase safe handling of the clamped parts, the unit ready for operation and a clamping pressure query should be integrated with the processing machine.

No. 6906P

Pump Unit

with 5 separate clamping circuits, single acting
max. operating pressure 400 bar



Order no.	Article no.	Clamping circuits	Flow rate Q [l/min.]	Valve type	Mode of operation	Weight [Kg]
326728	6906P-65319	5	2,5	4 x 3/2 +DS 1 x 3/2 +SV +DS	remote control	71

Design:

Compact, ready to plug in pump unit, ready for operation electrically and hydraulically. Complete with pressure control unit, electromagnetic valve, manometer, float switch, oil filling. The electrical controller is equipped with main switch, indicator lamps and flange sockets, carrying handle and two-part protective hood. Electrical connection complete with CEKON connector.

Application:

The pump unit is designed to operate hydraulic clamping systems. Clamping circuits 1 to 4 are for tool clamping, circuit 5 is for raising the hydraulic ball-roller strip.

Features:

Radial piston pump powered by standard three phase motor with thermal overload protection by means of thermocouples installed in the winding. Each of the 4 clamping circuits is equipped with a 3/2 seat valve. Four pressure switches (DS) are attached externally for the external pressure monitoring. In the 5th circuit, there are a 3/2-way valve, normally open, a pressure-limiting valve, and a pressure switch. The pressure adjustment is made using a pressure relief valve (DBV). The pressure monitoring of the operating circuit is made using the pressure switch (DS). Attention must be paid to the necessary pressure difference of approx. 40 bar between DS and DBV. The pump unit operates intermittently. In the case of a pressure drop, the pump unit is activated automatically by the pressure switch. The clamping pressure is indicated using illuminated push buttons. The installed float switch switches off the pump in the case of low oil level and outputs an optical signal.

Note:

Pay attention to faultless venting during the connection of the elements. Pumping in the case of pressure drop must be made maximum 2x per minute. The unit must not operate continuously. To ensure safe hydraulic tool clamping, clamping at ram and table is carried out in each case by means of a separate clamping circuit. The four pressure switches DS1-DS4 are used to provide external pressure monitoring of the four clamping circuits. The machine is automatically switched off if pressure drops in one clamping circuit or in the case of lack of oil. The electrical connection between press controller and power unit must be performed by the customer.

Hydraulic diagram:

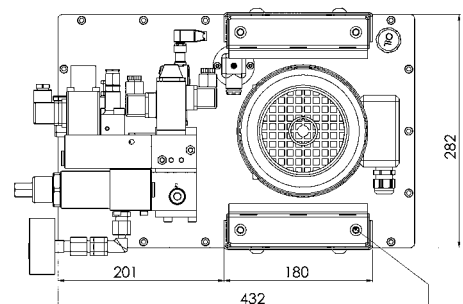
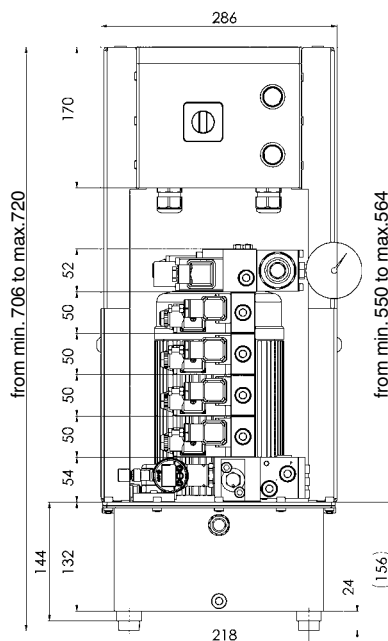
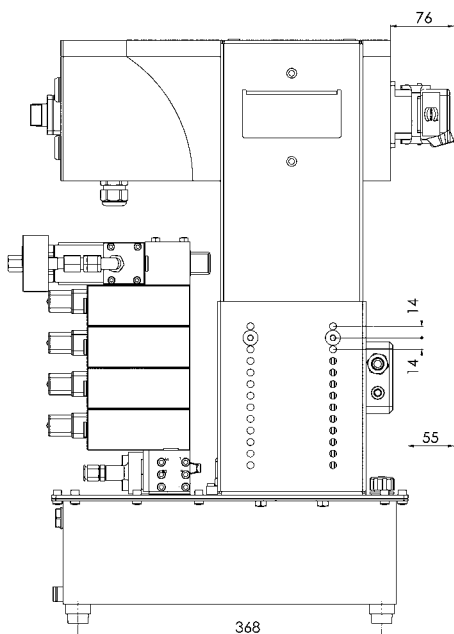
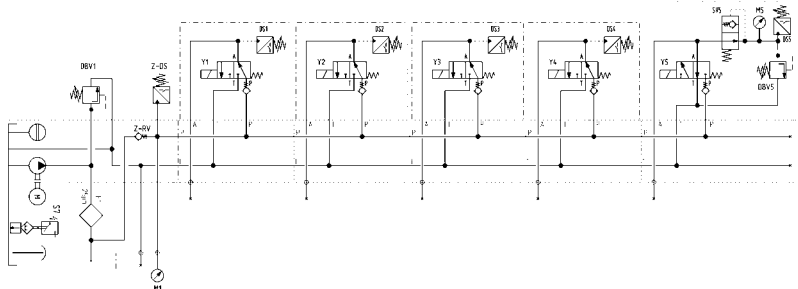

M8 thread for lifting device

Subject to technical alterations.

Pump Unit No. 6906P

Hydraulic specifications:

Max. operating pressure	400 bar
Min. operating pressure	40 bar
Oil capacity, reservoir	approx. 10 litre
Oil capacity, usable	approx. 4 litre
Oil-flow rate	2,5 l/min.
Valve type	
Clamping circuits 1-4	3/2 directional seat valve with external pressure switch for clamping pressure monitoring
Valve type	
Clamping circuit 5	3/2 directional seat valve, unclamped with power off, stop valve, pressure limiting valve and pressure switch for actuating the hydraulic ball-roller strips.
Hydraulic connection	thread G1/4
Noise level	max. 70 dB(A)
Ambient temp. range	-10° C to + 35° C
Position of use	upright
Pump type	Radial-piston pump with 3 pistons
Load cycle	max. 500/h
Hydraulic fluid	Hydraulic oil HLP and HLPD according to DIN 51524 part 2
Oil recommendation	HLP 22 and HLPD 22 or HLP 32 and HLPD 32
Viscosity	ISO VG 22 and 32 DIN 51519

Electric specifications:

Nominal voltage	400 V/50 Hz three-phase
Control voltage	24 V DC
Valve voltage	24 V DC
Motor speed	2900 1/min.
Sense of rotation	any
Motor rating	1,1 kW
Pump motor	Three-phase standard motor
Nominal current	3 A
Fuse, supply line	16 A slow-blow
Fuse, control line	1 A primary, 4 A secondary
Electric connection	Ölflex -100; 5x1,5 mm ² , 3 m long and connector CEE-16 A 6h
Protection class	IP 54
Duty cycle	max. 50% intermittent operation
Operation type	Socket for remote control
Fill-level monitoring	Float switch

Wiring circuit of pump unit with 4 clamping circuits, remote control

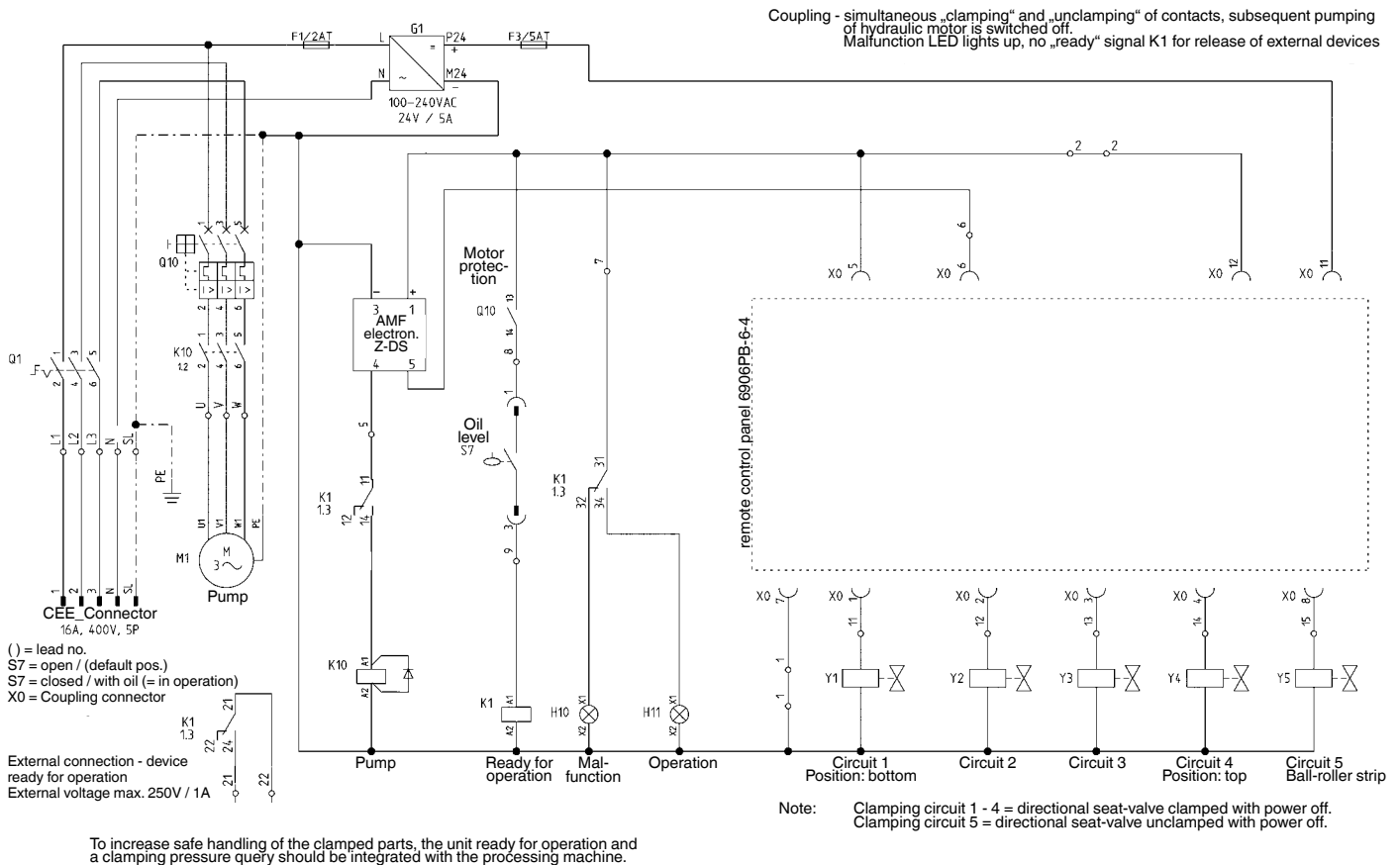

Wiring diagram for 4 clamping circuits

Pump unit with 4 clamping circuits for tool clamping at table and piston.

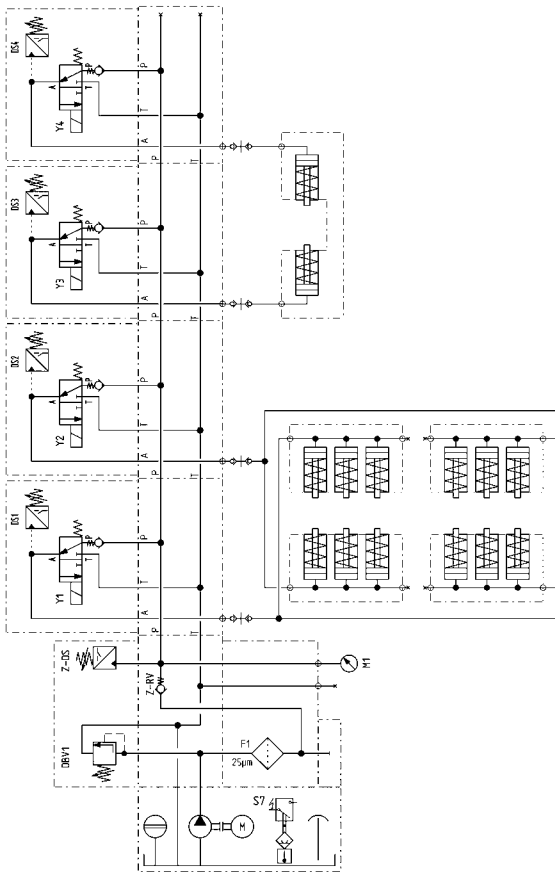

Wiring diagram for 5 clamping circuits

Pump unit with 5 clamping circuits for tool clamping at table and piston as well as additional actuation of the hydraulic ball-type roller bars.

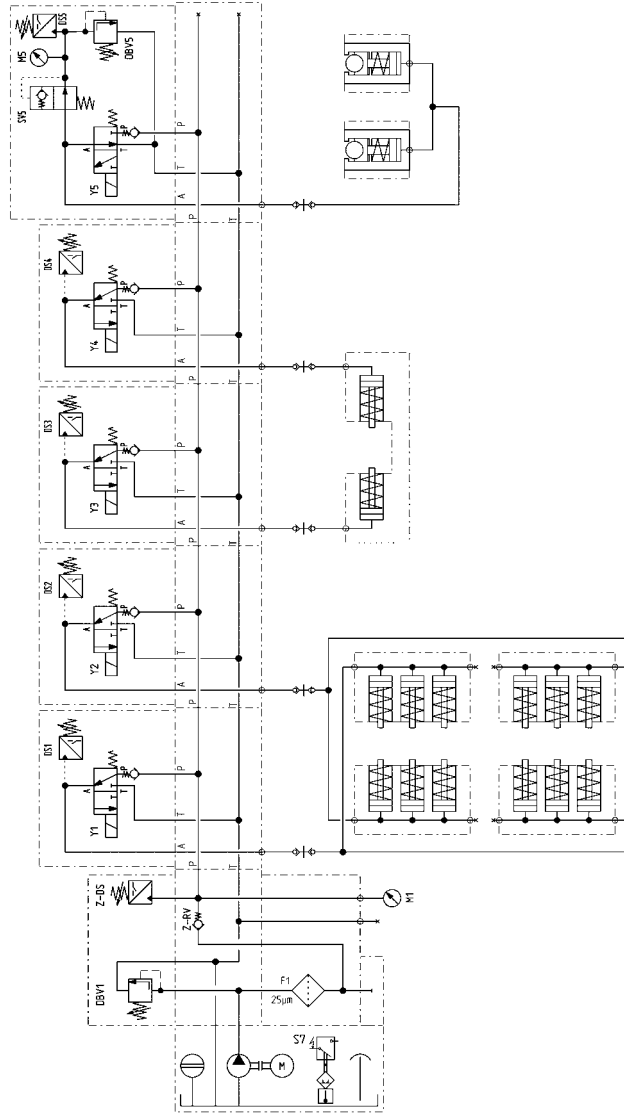

Note:

The pump unit must not start automatically when power supply is restored after a power failure. This does not apply to drive systems that may restart automatically without any risk of injury of operators or damage to the product to be processed. Note in accordance with VDE 0113-5.3: Safety in the event of power failure or pump unit failure.

Important note:

The external DS function of the pump unit can be integrated into the machine controller at the terminal housing by the operator. Ensure that the control circuit is correctly integrated into the machine controller!

External monitoring of AMF pump unit and pressure switches by customer's machine control

Attention! External voltage of external machine control

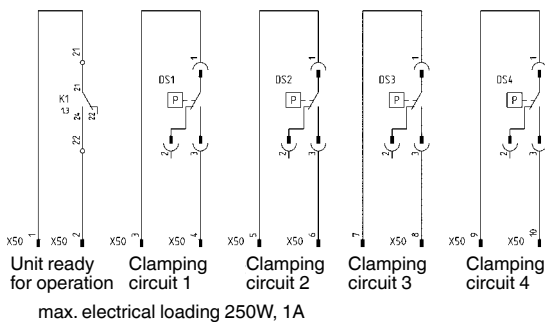

Attention! External voltage of external machine control

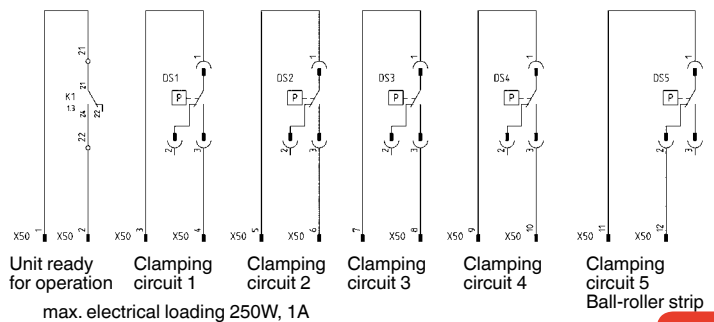

No. 6907B-4-4

Remote Control Switch with magnetic base

for 4 clamping circuits



Order no.	Article no.	Control voltage	Number of poles	L x W x H	Weight [g]
61663	6906PB-4-4	24 V =	13	160x75x75	2300

Design:

Compact polyester housing with magnetic base. Illuminated push buttons with screening, insert labels for clamping circuits, 1-4. 5 m cable with 13-pin coupling connector, protection class IP 65.

Application:

For pump unit No. 6906P-64319, Order no. 326702.

No. 6907B-4-5

Remote Control Switch with magnetic base and safety cover

for 4 clamping circuits



Order no.	Article no.	Control voltage	Number of poles	L x W x H	Weight [g]
60392	6906PB-4-5	24 V =	13	160x75x75	2500

Design:

Compact polyester housing with magnetic base, safety hood with lock. Illuminated push buttons with screening, insert labels for clamping circuits, 1-4. 5 m cable with 13-pin coupling connector, protection class IP 65.

Application:

For pump unit No. 6906P-64319, Order no. 326702.

No. 6907B-6-4

Remote Control Switch

for 5 clamping circuits



Order no.	Article no.	Control voltage	Number of poles	L x W x H	Weight [g]
253823	6906PB-6-4	24V =	13	230x75x75	1910

Design:

Compact polyester housing. Illuminated push-buttons with screening for clamping circuits 1-4 and insert labels. Push buttons for clamping (green) and releasing (red), without screening for clamping circuit 5. 5 m cable with 13-pin coupling connector, protection class IP 65.

Application:

For pump unit No. 6906P-65319, Order no. 326728.

Note:

Clamping circuits 1 to 4 are for operating hydraulic clamping elements, circuit 5 is for raising the hydraulic ball-roller strip. The controls are so arranged that unintentional operation of one of the clamping circuits automatically retracts the hydraulic ball-rollers.

No. 6907BS-1-1

Coupling Plug, 13-pin

without plug screw, without current bridge.



Order no.	Article no.	Control voltage	Number of poles	Weight [g]
126326	6906PBS-1-1	24 V =	13	40

Design:

Glasfibre-reinforced plastic with plug screw rugged version IP 65.

Application:

For connection directly to the machine control system. Suitable for pump unit and special units with 13-pin flange socket.

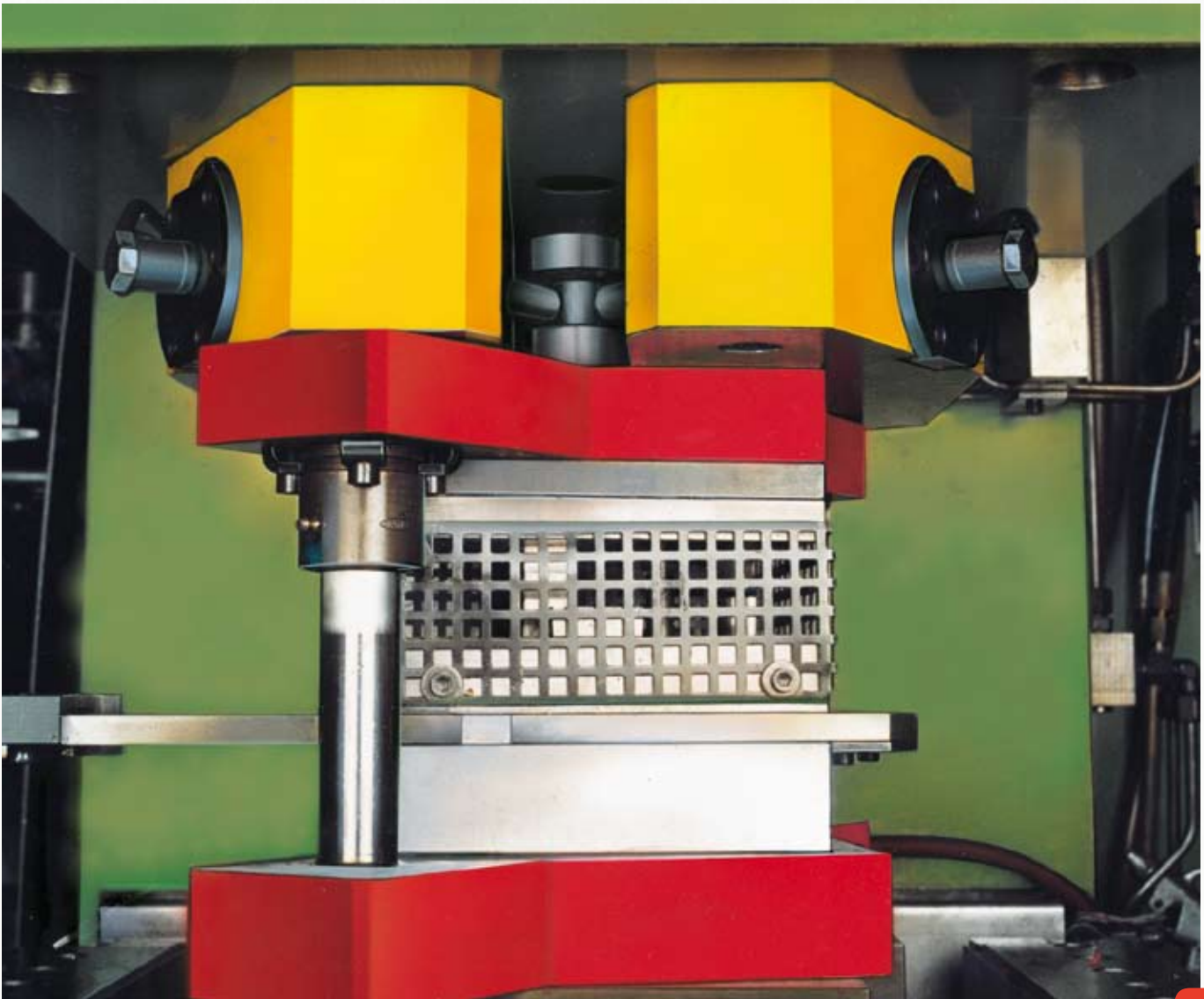
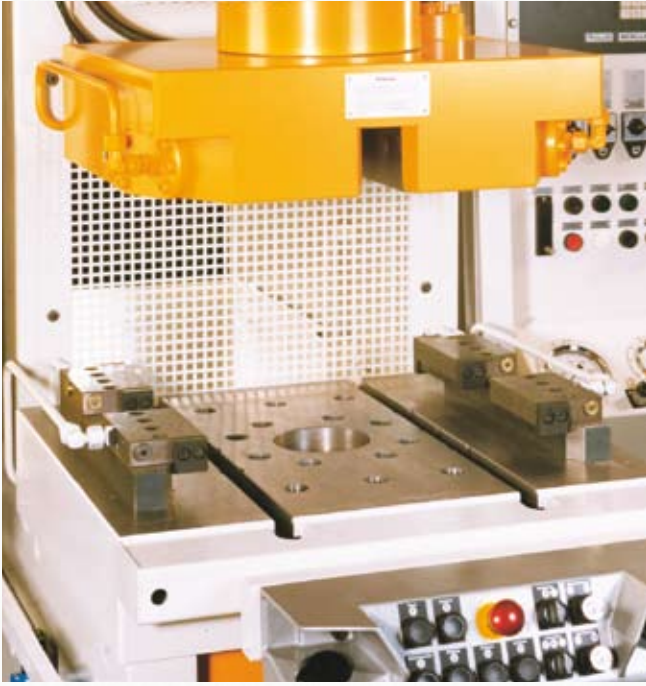

Subject to technical alterations.

No. 6945-22-20

Clamping Bar, short

single acting, with spring return,
max. operating pressure 400 bar, 1 clamping circuit.

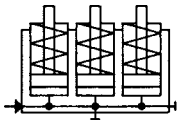

Order no.	Article no.	Clamping force at 400 bar [kN]	Stroke [mm]	Vol. total [cm ³]	Min. spring force per piston [N]	Weight [g]
61085	6945-22-20-1x3	60	6	8,7	120	3000

Suitable spacer bars:

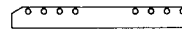

No. 6945-22-04



No. 6945-22-06

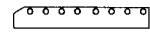

No. 6945-22-07

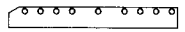

No. 6945-22-08

Design:

Cylinder body made of tempering steel, phosphated. Piston case-hardened and ground, built-in return spring, with stroke limitation.

Application:

For quick clamping and unclamping on press table or ram. Suitable for workpieces with uniform clamping rim. The clamping bar is bolted with a spacer bar directly onto the press table or ram.

On request:

Special sizes available on request.

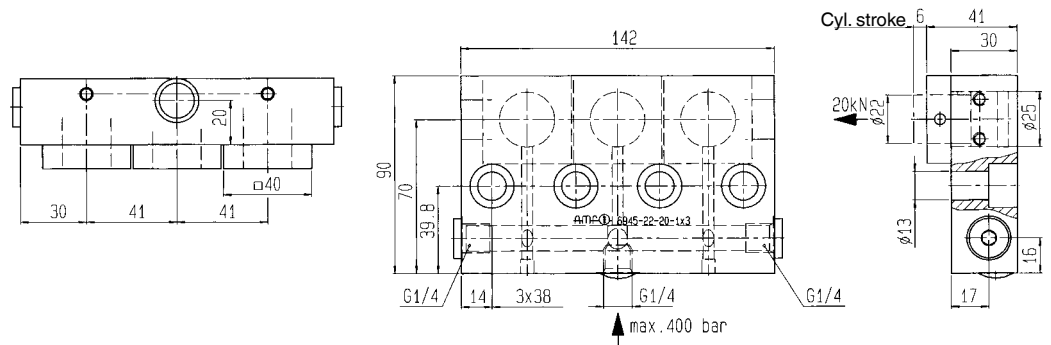

Sectional view:

Clamping strip no. 6945-22-20-1x3 with exchangeable clamping pistons

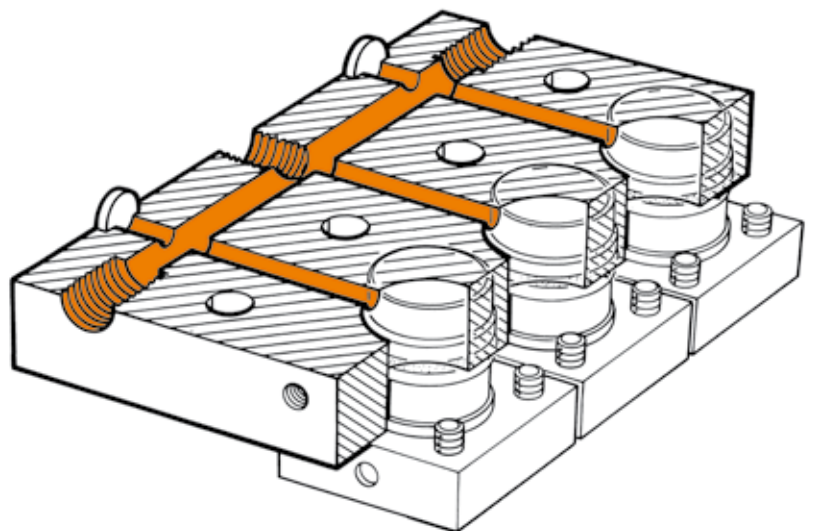

No. 6945-22-20

Clamping Bar, long

single acting, with spring return,
max. operating pressure 400 bar.



Order no.	Article no.	Clamping force at 400 bar [kN]	Stroke [mm]	Vol. total [cm ³]	Min. spring force per piston [N]	Weight [g]
61689	6945-22-20-2x3	2 x 60	6	17,4	120	6000
61630	6945-22-20-1x6	120	6	17,4	120	6000

Suitable spacer bar:

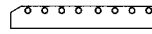

No. 6945-22-07

Design:

Cylinder body made of tempering steel, phosphated. Piston case-hardened and ground, built-in return spring, with stroke limitation.

Application:

For quick clamping and unclamping on press table or ram. Suitable for workpieces with uniform clamping rim. The clamping bar is bolted with a spacer bar directly onto the press table or press ram.

On request:

Special sizes available on request.

No. 6945-22-20-2x3

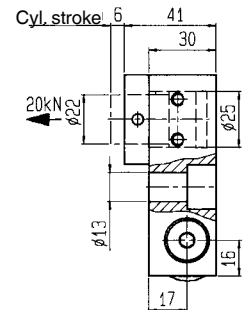
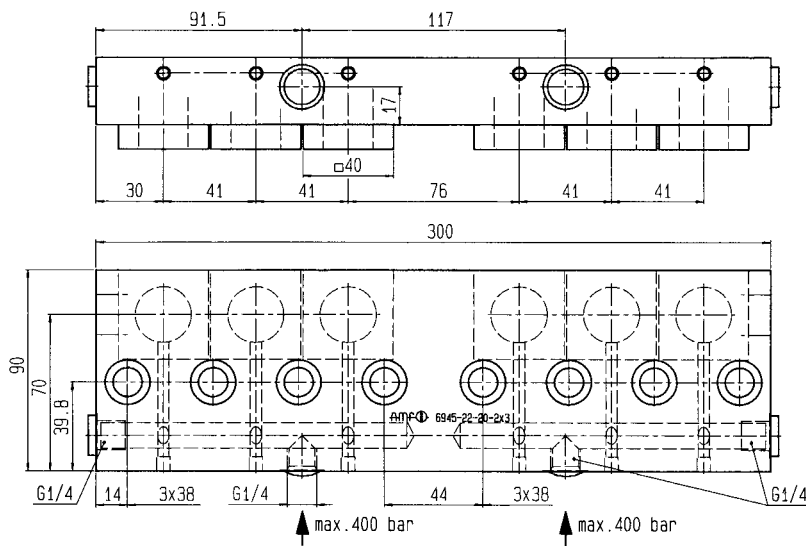
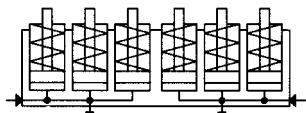

No. 6945-22-20-1x6

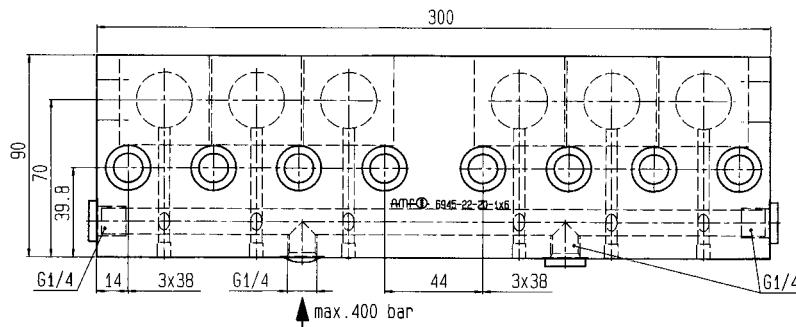
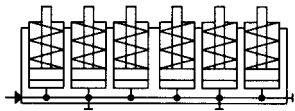

No. 6945-22-20

Clamping Bar, long

single acting, with spring return,
max. operating pressure 400 bar.

Order no.	Article no.	Clamping force at 400 bar [kN]	Stroke [mm]	Vol. total [cm ³]	Min. spring force per piston [N]	Weight [g]
61622	6945-22-20-2x4	2 x 80	6	23,2	120	8000
61697	6945-22-20-1x8	160	6	23,2	120	7840

Suitable spacer bars:

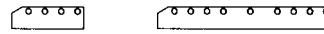

No. 6945-22-06

No. 6945-22-08



Design:

Cylinder body made of tempering steel, phosphated. Piston case-hardened and ground, built-in return spring, with stroke limitation.

Application:

For quick clamping and unclamping on press table or ram. Suitable for workpieces with uniform clamping rim. The clamping bar is bolted with a spacer bar directly onto the press table or press ram.

On request:

Special sizes available on request.

No. 6945-22-20-2x4

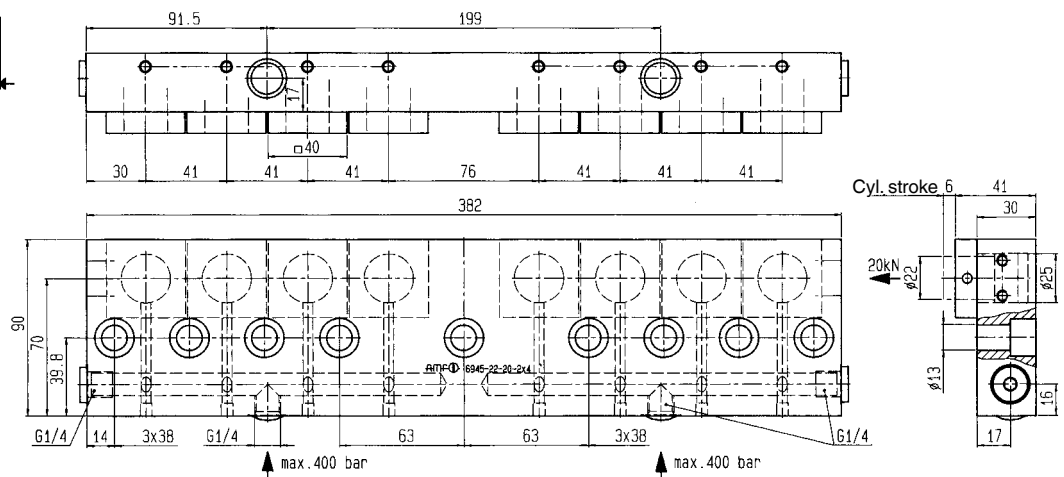
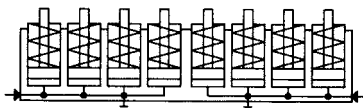

No. 6945-22-20-1x8

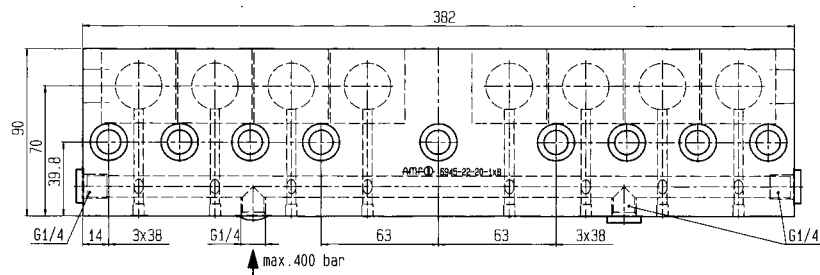
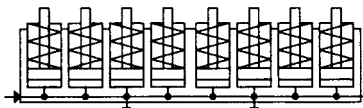

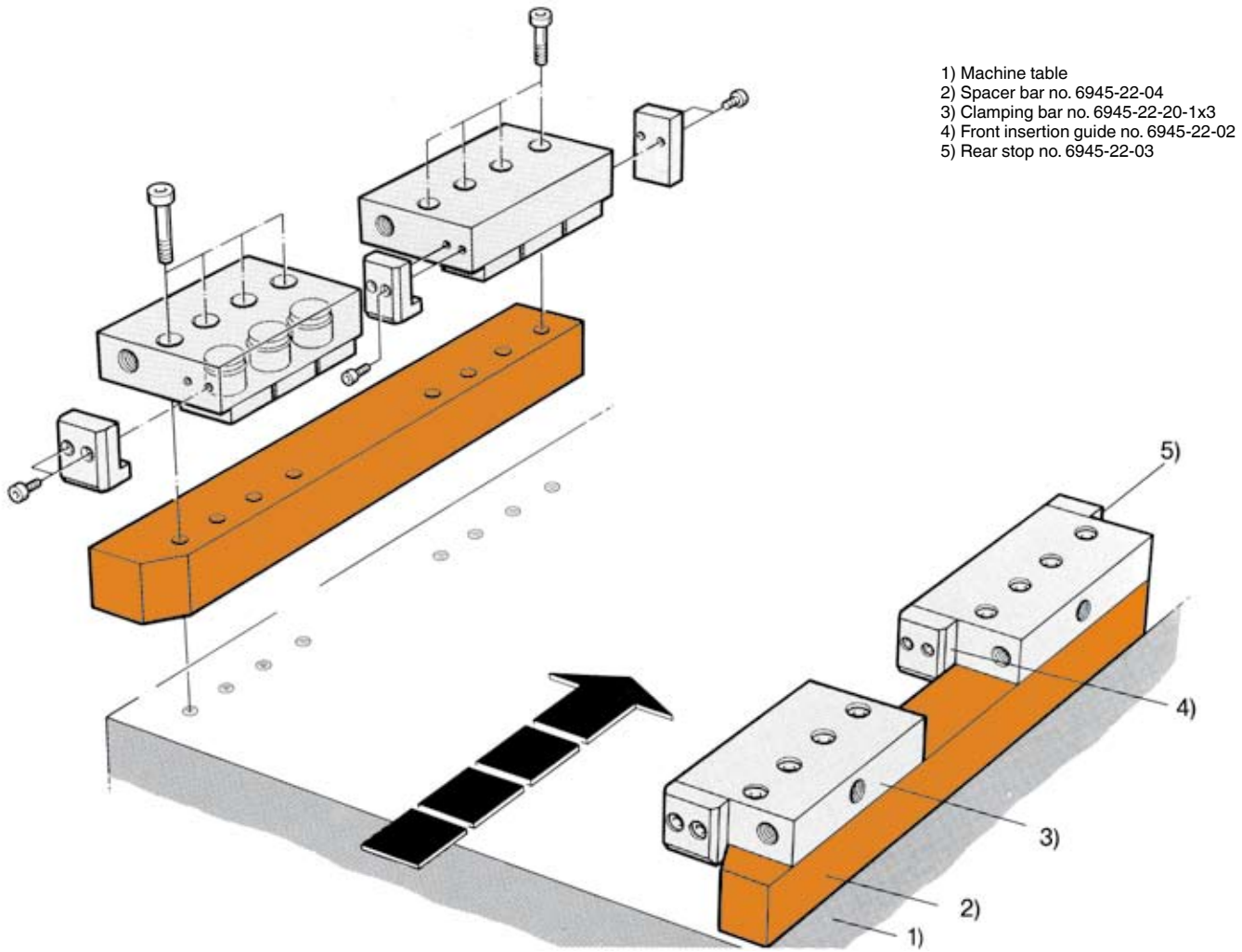

- 1) Machine table
- 2) Spacer bar no. 6945-22-04
- 3) Clamping bar no. 6945-22-20-1x3
- 4) Front insertion guide no. 6945-22-02
- 5) Rear stop no. 6945-22-03

No. 6945-22-04
Spacer Bar



Order no.	Article no.	L x W x H	Weight [g]
61101	6945-22-04	425 x 50 x 44,5	7300

Design:

Tempering steel, phosphated. Tolerance of distance between holes ± 0.2 .

Application:

Spacer and guide bar for a clamping-rim or tool-pallet height of 30 mm.

Note:

For clamping bar: No. 6945-22-20-1x3.

On request:

Special sizes available on request.

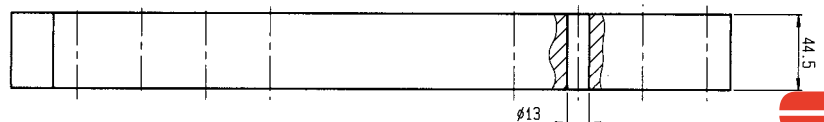
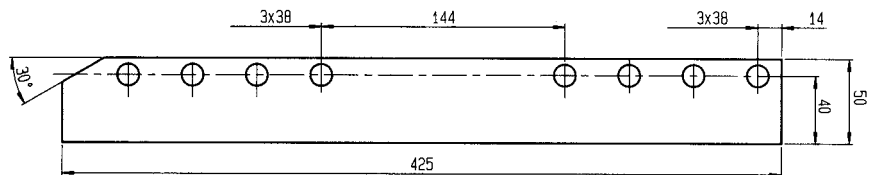

Subject to technical alterations.

No. 6945-22-06
Spacer Bar



Order no.	Article no.	L x W x H	Weight [g]
61408	6945-22-06	167 x 50 x 44,5	2670

Design:

Tempering steel, phosphated. Tolerance of distance between holes ± 0.2 .

Application:

Spacer and guide bar for a clamping-rim or tool-pallet height of 30 mm.

Note:

- For clamping bars:
 - No. 6945-22-20-1x3
 - No. 6945-22-20-2x4
 - No. 6945-22-20-1x8

On request:

Special sizes available on request.

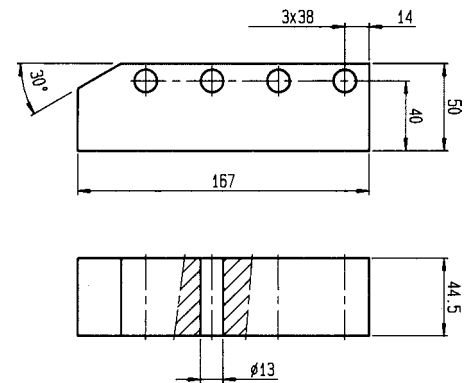

No. 6945-22-07
Spacer Bar



Order no.	Article no.	Article no.	Weight [g]
61705	6945-22-07	325 x 50 x 44,5	5800

Design:

Tempering steel, phosphated. Tolerance of distance between holes ± 0.2 .

Application:

Spacer and guide bar for a clamping-rim or tool-pallet height of 30 mm.

Note:

- For clamping bars:
 - No. 6945-22-20-1x3
 - No. 6945-22-20-2x3
 - No. 6945-22-20-1x6

On request:

Special sizes available on request.

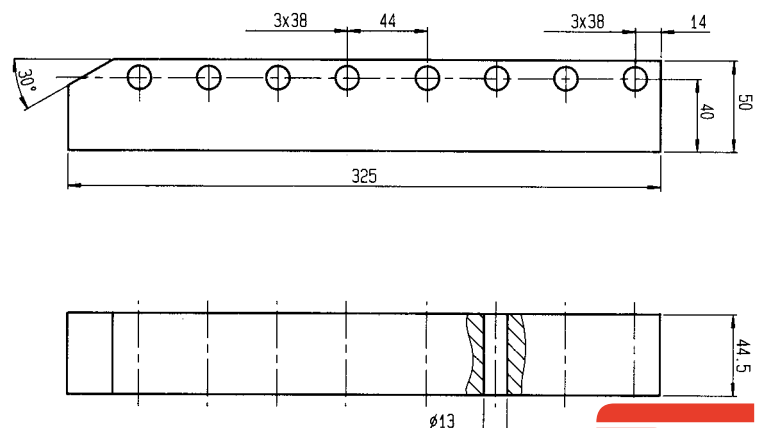

No. 6945-22-08
Spacer Bar



Order no.	Article no.	L x W x H	Weight [g]
61713	6945-22-08	407 x 50 x 64	10500

Design:

Tempering steel, phosphated. Tolerance of distance between holes ± 0.2 .

Application:

Spacer and guide bar for a clamping-rim or tool-pallet height of 50 mm.

Note:

- For clamping bars:
 - No. 6945-22-20-1x3
 - No. 6945-22-20-2x4
 - No. 6945-22-20-1x8

On request:

Special sizes available on request.

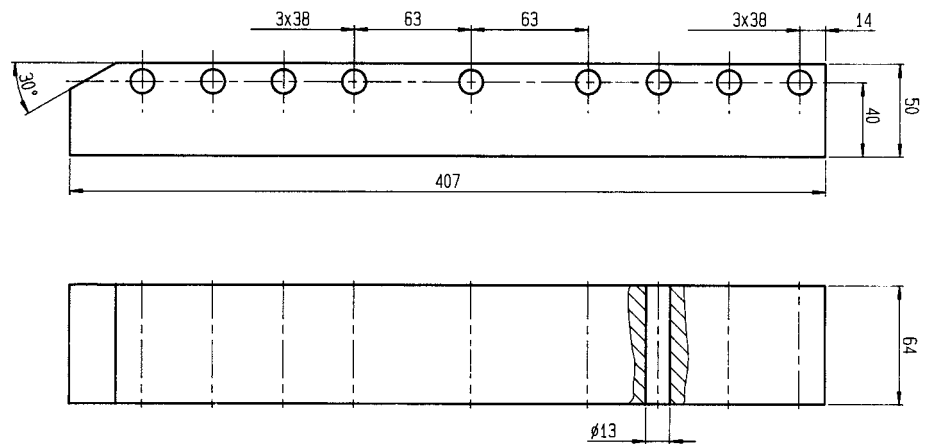

No. 6945-22-02
Front Insertion Guide



Order no.	Article no.	Weight [g]
61077	6945-22-02	300

Design:

Tempering steel, blued and hardened. Mounting bolts supplied.

Application:

For safe guidance of die pallet into press. This guide protects the clamping pistons in the clamping bar.

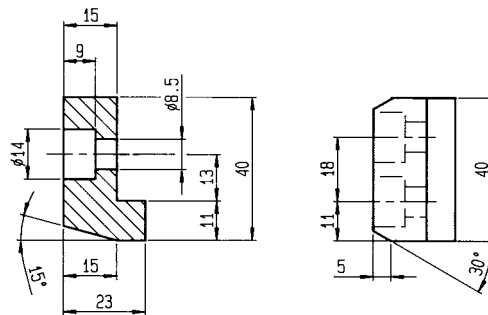

No. 6945-22-03
Rear Stop



Order no.	Article no.	Weight [g]
61093	6945-22-03	250

Design:

Tempering steel, blued and hardened. Mounting bolts supplied.

Application:

Stop for die pallet in the press.

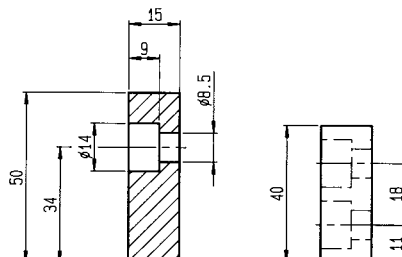

No. 6945-11-**

Clamping Head, complete with base

single acting, with spring return,
max. operating pressure 400 bar.

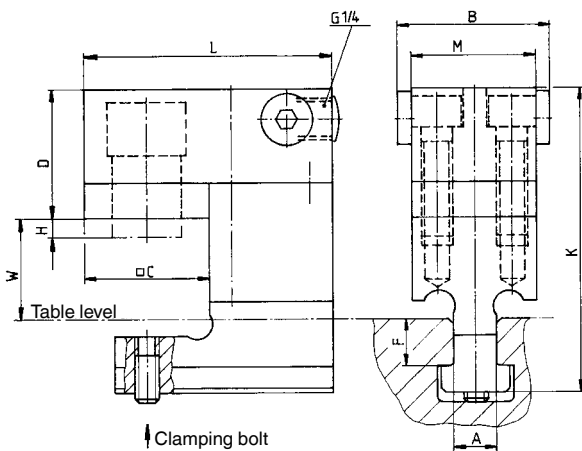
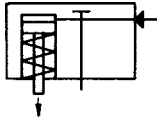

Order no.	Article no.	Clamping force at 400 bar [kN]	Stroke H [mm]	Vol. [cm ³]	Spring force min. [N]	Weight [g]
61184	6945-11-20x14x30	20	6	2,9	120	1471
61416	6945-11-20x18x30	20	6	2,9	120	1581
61192	6945-11-32x18x30	32	8	6,4	260	2855
61424	6945-11-32x22x30	32	8	6,4	260	3095
61200	6945-11-63x22x30	63	10	16,0	580	4660
61432	6945-11-63x28x30	63	10	16,0	580	5080
64006	6945-11-94x28x50	94	12	28,5	920	10380

Design:

Cylinder body made of tempering steel, blued. Piston case-hardened and ground. Built-in return spring, complete with locating pin.

Application:

The clamping head is used to clamp press tools on the press table and ram. The unit is inserted into the T-slot and moved above the clamping spot at the tool to be clamped. The clamping heads of size 20-63kN are suitable for a clamping height of 29 mm. Size 94kN suits a clamping height of 50 mm. To adjust other clamping heights, spacer plates of 10 mm and 20 mm are available.

Features:

Small dimensions. The hydraulic oil supply can be connected to any of the three sides.

Note:

If a clamping head is retrofitted with an spacer plate, the locating pin must be removed from the lower part of clamping head. T-Slot dimension F has to be considered urgently.

Dimensions

Order no.	Article no.	A	B	C	D	F	H	K	L	M	W
61184	6945-11-20x14x30	14	50	40	41,0	15	6	95,0	80	40	31
61416	6945-11-20x18x30	18	50	40	41,0	20	6	102,0	80	40	31
61192	6945-11-32x18x30	18	60	50	53,0	20	8	114,0	100	50	31
61424	6945-11-32x22x30	22	60	50	53,0	25	8	123,0	100	50	31
61200	6945-11-63x22x30	22	70	60	63,0	25	10	133,0	120	60	31
61432	6945-11-63x28x30	28	70	60	63,0	30	10	142,0	120	60	31
64006	6945-11-94x28x50	28	90	80x70	79,5	34	12	187,5	150	80	55

No. 6945-11-***

Holder for Clamping Head

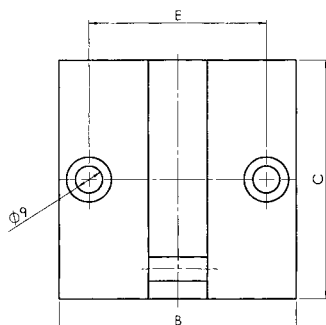
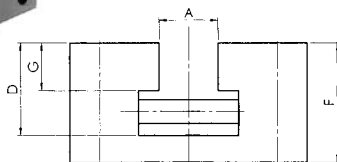

Order no.	Article no.	A [mm]	for T-Slot	for Clamping Head	Weight [g]
110700	6945-11-006	16	14	6945-11-**-**x14x**	1600
110692	6945-11-005	20	18	6945-11-**-**x18x**	1550
255687	6945-11-003	24	22	6945-11-**-**x22x**	2120
255752	6945-11-004	30	28	6945-11-**-**x28x**	2090

Design:

Steel, blued.

Application:

For parking clamp head No. 6945-11-**-*** during tool changing.

Note:

Untoleranced dimensions are to DIN ISO 2768 medium.

On request:

Special versions available on request.

Dimensions

Order no.	Article no.	B	C	D	E	F	G
110700	6945-11-006	80	80	25	60	35	12
110692	6945-11-005	80	80	31	60	40	16
255687	6945-11-003	90	90	40	70	50	20
255752	6945-11-004	90	90	50	70	60	25

No. 6945-11-**

Clamping Head

single acting, with spring return,
max. operating pressure 400 bar.

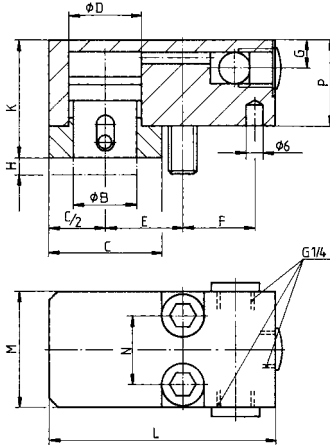
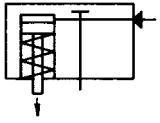

Order no.	Article no.	Clamping force at 400 bar [kN]	Stroke H [mm]	Vol. [cm³]	ISO 4762 (2 pieces)	Md max. [Nm]	Spring force min. [N]	Weight [g]
61218	6845-11-20	20	6	2,9	M10x35-10.9	65	120	790
61234	6845-11-32	32	8	6,4	M12x45-10.9	120	260	1625
60327	6845-11-63	63	10	16,0	M16x50-8.8	200	580	2700
63990	6945-11-94	94	12	28,5	M20x70-12.9	670	920	5600

Design:

Cylinder body made of tempering steel, blued. Piston case-hardened and ground. Built-in return spring.

Application:

The upper part of the clamping head can be screwed on direct on clamping devices.

On request:

Special sizes available on request.

Dimensions

Order no.	Article no.	dia. B	C	dia. D	E	F	G	K	L	M	N	P
61218	6845-11-20	22	40	25	27	26	10	41,0	80	40	24	30
61234	6845-11-32	26	50	32	34	32	13	53,0	100	50	28	41
60327	6845-11-63	38	60	45	41	38	15	63,0	120	60	34	48
63990	6945-11-94	47	70	55	50	55	15	79,5	150	80	46	62

No. 6945-11-**

Base for Clamping Head

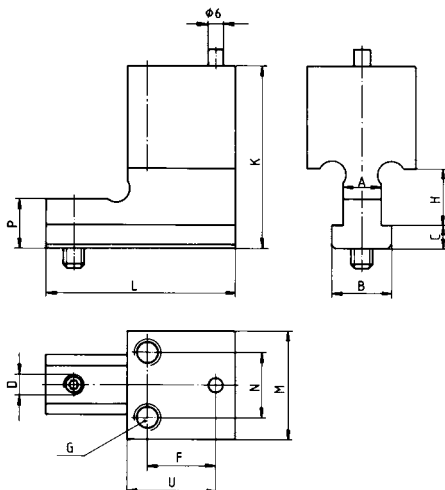

Order no.	Article no.	A [mm]	H [mm]	Weight [g]
61226	6945-11-20x14	14	25	680
61440	6945-11-20x18	18	25	790
61242	6945-11-32x18	18	25	1230
61457	6945-11-32x22	22	30	1470
60285	6945-11-63x22	22	30	1960
61465	6945-11-63x28	28	37	2380
60475	6945-11-94x28	28	36	4750

Design:

Tempering steel, blued. Complete with locating pin.

On request:

Special sizes available on request.

Maßtabelle

Bestell-Nr.	Artikel-Nr.	B	C	D	F	G	K	L	M	N	P	U
61226	6945-11-20x14	22	8	M8	26	M10	65,0	70	40	24	18	32,7
61440	6945-11-20x18	28	10	M8	26	M10	72,0	70	40	24	24	32,7
61242	6945-11-32x18	28	10	M10	32	M12	73,0	90	50	28	24	40,4
61457	6945-11-32x22	35	14	M10	32	M12	82,0	90	50	28	32	40,4
60285	6945-11-63x22	35	14	M10	38	M16	85,0	110	60	34	32	48,3
61465	6945-11-63x28	44	18	M10	38	M16	94,0	110	60	34	40	48,3
60475	6945-11-94x28	44	19	M10	55	M20	125,5	140	80	46	47	69,0

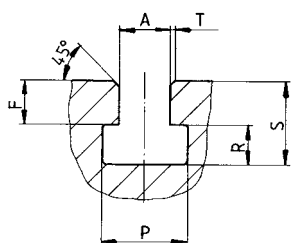

Dimensions for T-slots in accordance with DIN 650

A	F* min.	F* max.	P	R	S min.	S max.	T max.
14 ^{H8}	12	19	23 ⁺²	9 ⁺²	23	28	1,6
18 ^{H8}	16	24	30 ⁺²	12 ⁺²	30	36	1,6
22 ^{H8}	20	29	37 ⁺²	16 ⁺²	38	45	1,6
28 ^{H8}	26	36	46 ⁺²	20 ⁺²	48		

* Please check this dimension on your machine.

Subject to technical alterations.

No. 6945-11-**-**

Adaptor Plate

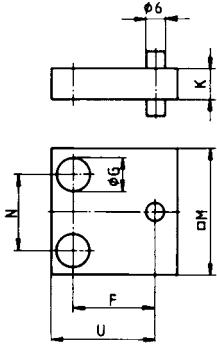
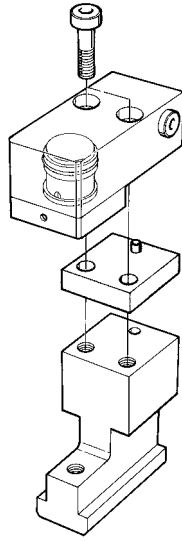

Order no.	Article no.	ISO 4762 (2 pieces)	F	dia. G	K	M	N	U	Weight [g]
61259	6945-11-20-08-10	M10x45	26	11	10	40	24	32,7	190
61267	6945-11-20-08-20	M10x50	26	11	20	40	24	32,7	300
61275	6945-11-32-08-10	M12x50	32	13	10	50	28	40,4	290
61283	6945-11-32-08-20	M12x60	32	13	20	50	28	40,4	485
61291	6945-11-63-08-10	M16x60	38	17	10	60	34	48,3	500
61309	6945-11-63-08-20	M16x70	38	17	20	60	34	48,3	770
63503	6945-11-94-08-20	M20x85	55	21	20	80	46	69,0	1500

Design:

Tempering steel, blued, with locating pin and two mounting bolts ISO 4762.

Application:

The adaptor plate is fitted between of the clamping head and it's base in order to obtain a different clamping height.

On request:

Special sizes available on request.

No. 6945-11-**-10

Clamping Piston, complete



Order no.	Article no.	Clamping force at 400 bar [kN]	Stroke [mm]	Vol. [cm ³]	Weight [g]
61473	6945-11-20-10	20	6	2,9	220
61481	6945-11-32-10	32	8	6,4	400
61499	6945-11-63-10	63	10	16,0	730
64089	6945-11-94-10	94	12	28,5	1200

Design:

Tempering steel, piston case-hardened and ground. Cover blued.

Application:

For simple retrofitting into existing fixture body. Suitable for clamping bar No. 6945-22-20-**-** and clamping head No. 6945-11-**-**.

Installation dimensions

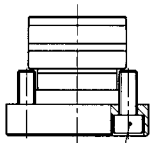
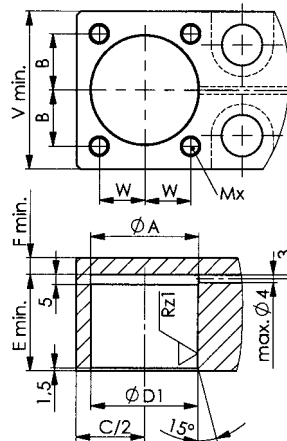

4xISO 4762-MxT/Md.

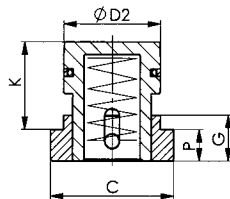

Dimensions

Order no.	Article no.	dia. A	B ±0.1	C	dia. D1	dia. D2	E	F	G	Md [Nm]	K	P	M x T	Depth	V	W
61473	6945-11-20-10	25,5	13,0	40	25 +0,033	25 -0,020/-0,041	26	4	14,0	10	26	11,0	M 6x12- 8.8	10	40	13
61481	6945-11-32-10	32,5	16,0	50	32 +0,039	32 -0,025/-0,050	33	7	15,0	25	33	12,0	M 8x20- 8.8	20	50	16
61499	6945-11-63-10	45,5	21,0	60	45 +0,039	45 -0,025/-0,050	39	9	20,0	36	39	15,0	M 8x20- 10.9	20	60	21
64089	6945-11-94-10	55,5	28,5	70	55 +0,046	55 -0,030/-0,060	49	13	25,5	79	49	17,5	M10x25- 12.9	23	80	23

Subject to technical alterations.

No. 6954

Swivel Clamping Strap, hydraulic clamping, mechanic unclamping

single acting,
max. operating pressure 250 bar /
400 bar at size 50.

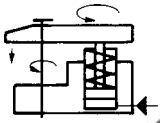

Size 14-22

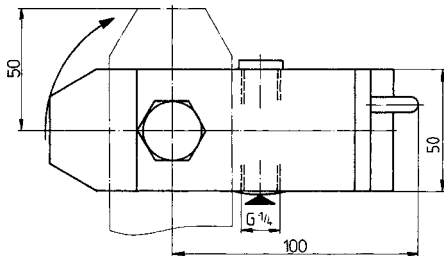
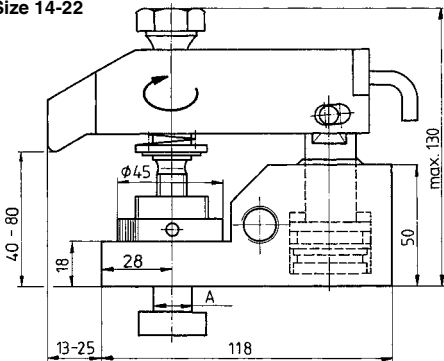

Size 50N28

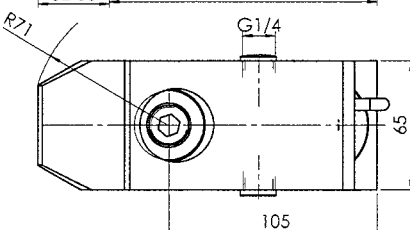
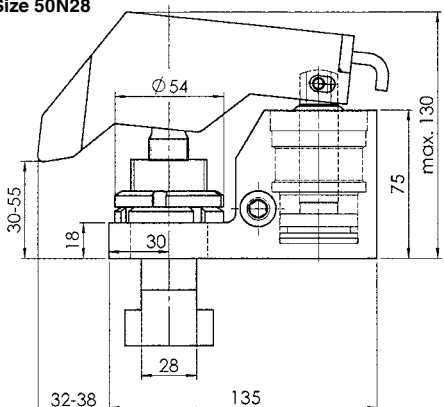

Order no.	Article no.	A	Clamping height [mm]	Clamping stroke [mm]	Clamping force at 250 bar			Piston dia. [mm]	Vol.	Spring force min. [N]	Weight [g]
					below [kN]	centre [kN]	top [kN]				
65417	6954-14	14	40 - 80	0 - 5	30	26	24	32	4,8	150	3320
65433	6954-16	16	40 - 80	0 - 5	30	26	24	32	4,8	150	3320
65458	6954-18	18	40 - 80	0 - 5	30	26	24	32	4,8	150	3320
65474	6954-20	20	40 - 80	0 - 5	30	26	24	32	4,8	150	3320
65490	6954-22	22	40 - 80	0 - 5	30	26	24	32	4,8	150	3320
9613	6954-50N28	28	30 - 55	0 - 8	63*	59*	56*	40	13,8	470	3320

* Max. clamping force at 400 bar operating pressure.

Design:

Clamp (with swivel lock), clamping bolt and sleeve tempered and blued. Cylinder body made of tempering steel, blued. Piston and piston rod case-hardened and ground. Wiper at piston rod, venting screw and sinter metal breather. Long piston guiding and Teflon guide ring at piston.

Application:

The swivel clamping strap is intended for the most frequently occurring tool clamping heights.

Features:

Large clamping range, fast height adjustment to the required tool clamping edge height. The swivel clamping strap is inserted directly into the T-slot of the press. The workpiece can also be removed vertically upwards as the clamping bar can be swivelled away manually. The clamping bar is mechanically locked in the clamping position.

Note:

For single acting cylinders there is risk of sucking in coolant during return stroke. In this case the cylinders have to be protected against the direct effect of coolant. The built in sinter metal breather should be protected.

On request:

Further sizes, specially made bases for bigger clamping heights and other T-slot sizes on request.

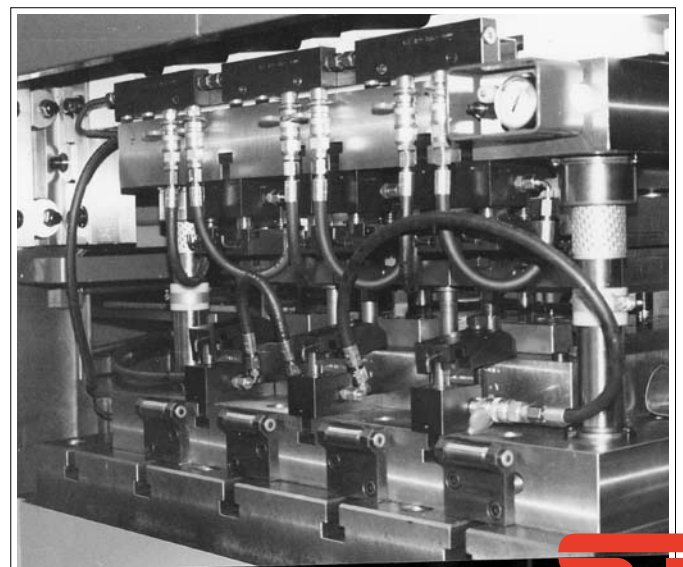

Please fill in the following form so we can use your data to prepare an offer for the right clamping system for your individual requirements. We will respond as soon as possible.

Please use a copy of this page, do not remove it from the catalogue:

Company/address:

.....

Name/telephone:

.....

Dept.:

.....

PRESS:

- | | | | |
|-------------------------------|-------|---------------------|-------|
| 1. Manufacturer or press type | | 4. Max. stroke rate | |
| 2. Pressing force | | 5. Closing height | |
| 3. Max. stroke | | 6. Wiping force | |

PRESS TABLE:

7. Table surface W x D

8. Table thickness

9. Table opening, if present

10. No. of T-grooves (table)

11. Pitch of T-grooves (table)

12. Dimensions of T-grooves (table) A= F= P= R= S=

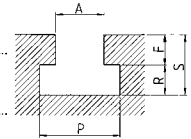

PRESS PISTON:

13. Piston size W x D

14. No. of T-grooves (piston)

15. Pitch of T-grooves (piston)

16. Dimensions of T-grooves (piston) A= F= P= R= S=
17. Diameter of present clamping stud

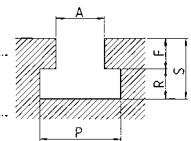

TOOL:

18. Maximum weight of upper tool part

19. Maximum weight of part

20. Thickness of tool base plates
 bottom/top

21. Minimum and maximum tool
 dimensions W x H x D

22. Important notes

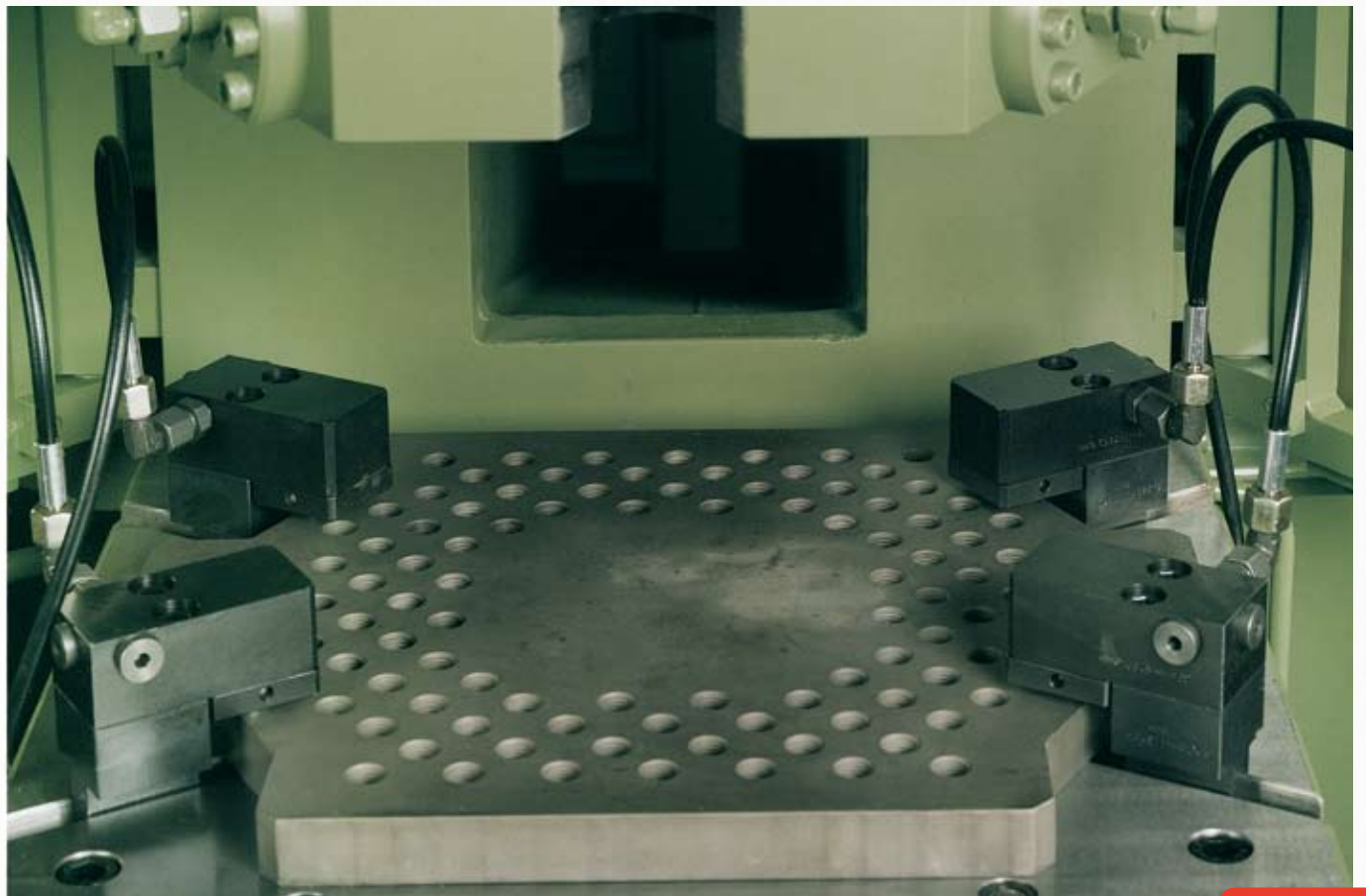

Nr. 6946

Wedge clamp

double-acting
max. operating pressure 350 bar (400 bar*).



Order no.	Article no.	Clamping force [kN]	max. operating pressure [kN]	With positioning monitoring	Without position monitoring	Weight [Kg]
325134	6946-25-L	25	36	-	√	2,6
325142	6946-25-B	25	36	√	-	2,6
325159	6946-50-L	50	72	-	√	6,1
325167	6946-50-B	50	72	√	-	6,1
325175	6946-100-L	100	145	-	√	11,5
325183	6946-100-B	100	145	√	-	11,5
325191	6946-160-L	160	230	-	√	23,0
325209	6946-160-B	160	230	√	-	23,0

Design:

Steel block cylinder housing, burnished. Housing and clamping bolt tempered. Piston hardened and ground. The fastening screws are included in the scope of delivery.

Application:

Wedge clamps are used for clamping the tools on presses and injection moulding machines. The clamping bolt clamps at a 20° diagonal to the tool, which results in a friction connection.

Note:

The maximum permitted load per clamp must not be exceeded. The clamping force acts vertically on the clamping point which applies very low sliding forces to the tool.

* When using fixing screws of 10.9 quality a maximum operating force of 400 bar is permitted. A mounting surface with corresponding thread resistance (at least corresponding to St 50) is required.

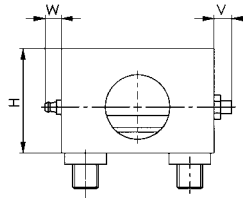
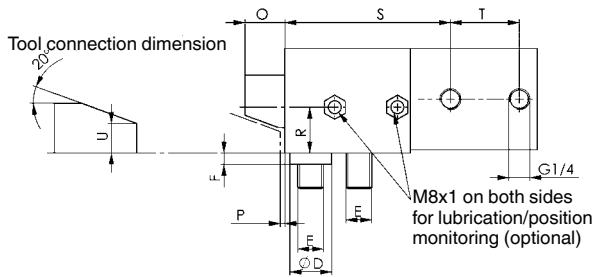
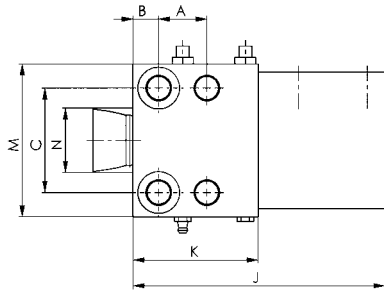

Dimensions

Order no.	Article no.	A	B	C ±0,02	ØD H8	E	F	H	J	K	M	N	O	P	R	S	T	U	V	W	Supplied screws ISO 4762 - 12.9
325134	6946-25-L	24	14	48	18	m12	6	48	122	58	70	30	20	3	21,5	78	33	15	12	11	M12x60
325142	6946-25-B	24	14	48	18	M12	6	48	122	58	70	30	20	3	21,5	78	33	15	12	11	M12x60
325159	6946-50-L	30	16	65	26	M16	7	65	157	78	95	40	25	3	28,5	103	43	18	6	11	M16x70
325167	6946-50-B	30	16	65	26	M16	7	65	157	78	95	40	25	3	28,5	103	43	18	6	11	M16x70
325175	6946-100-L	38	20	85	30	M20	11	80	190	100	120	56	25	3	37,0	127	51	25	16	11	M20x90
325183	6946-100-B	38	20	85	30	M20	11	80	190	100	120	56	25	3	37,0	127	51	25	16	11	M20x90
325191	6946-160-L	50	25	106	35	M24	11	105	222	120	150	70	30	3	49,0	148	57	30	8	11	M24x120
325209	6946-160-B	50	25	106	35	M24	11	105	222	120	150	70	30	3	49,0	148	57	30	8	11	M24x120

Subject to technical alterations.

No. 6945-28-***

Clamping Stud Holder, hydraulic

for direct attachment to ram.

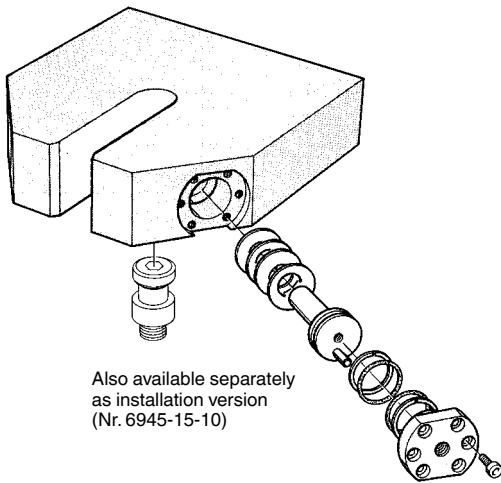

Also available separately
as installation version
(Nr. 6945-15-10)

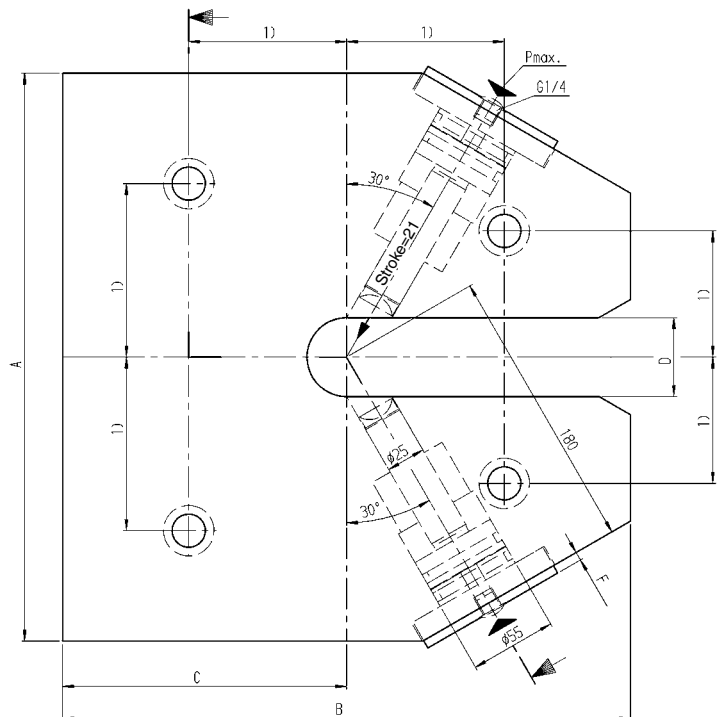
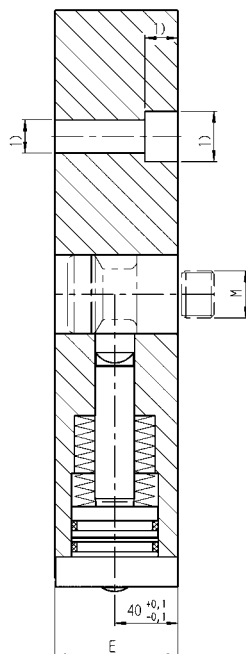

1) Special dimensions available on request

Order no.	Article no.	max. operating pressure [bar]	Pull Force cylinder [kN]	Clamping stud dia. [mm]	Spring force min. [N]	Weight [Kg]
6163	6945-28-007	230	54	40	1200	47
61390	6945-28-010	400	94	50	1200	66

Design:

Cylinder body made of tempering steel. External, vertical surfaces painted yellow. Complete with two clamping pistons No. 6945-15-10 and cover plates.

Application:

Clamping stud No. 6945-02-04-***, which is screwed into the tool, is gripped hydraulically when it has entered the opening in the clamping-pin chuck.

Note:

No DIN clamping studs must be used for the clamping stud holder. Mounting holes can be incorporated on request. Untoleranced dimensions are to DIN ISO 2768 medium.

On request:

Special versions available on request.

Dimensions

Order no.	Article no.	A	B	C	D +0.1/+0.3	E	F	M
6163	6945-28-007	360	270	135	40	78	1,5	M24x1,5
61390	6945-28-010	360	360	180	50	78	5,5	M30x2,0

No. 6945-15-10

Clamping Piston, complete

for stud clamping,
max. operating pressure 400 bar.

Order no.	Article no.	Weight [g]
61382	6945-15-10	1700

Design:

Piston made of steel, tempered and ground. Cover made of tempering steel. Complete with disc springs, O-rings, support rings, dowel pin and mounting screws ISO 4762.

Application:

This clamping piston can be retrofitted to your original ram plate.

Note:

The use of clamping stud No. 6945-02-04-009 in combination with clamping piston set No. 6945-15-10 is restricted to a maximum operating pressure of 230 bar.

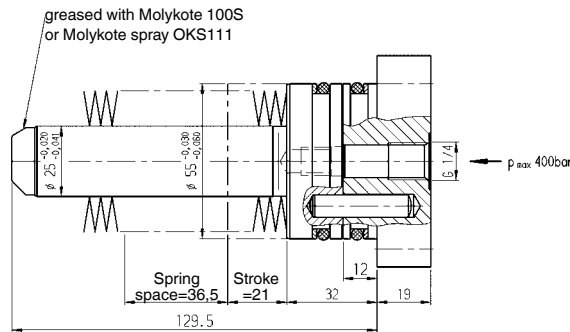
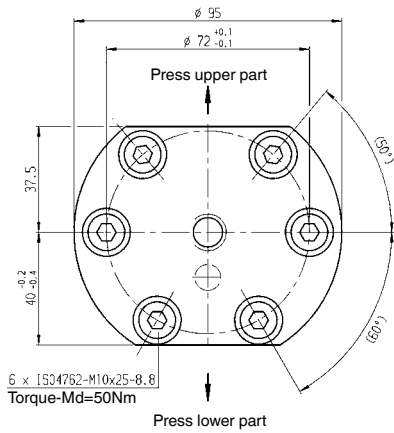

Installation dimensions

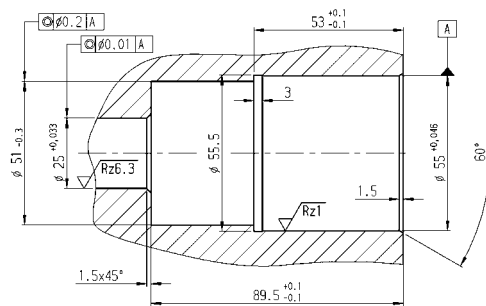

No. 6945-02-04

Clamping Stud

Order no.	Article no.	dia. A	dia. D	M	Weight [g]
61671	6945-02-04-009	22	40	M24x1,5	760
61150	6945-02-04	32	50	M30x2,0	945

Design:

Tempering steel, tempered, inductively hardened clamping area.

Note:

Clamping stud does not conform to DIN, suitable only for use with our hydraulic stud clamping.

On request:

Special sizes available on request.

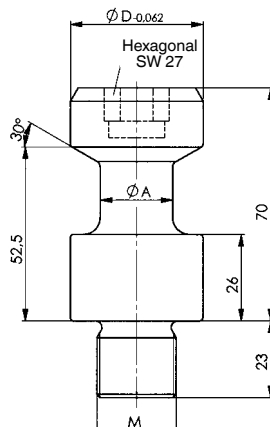

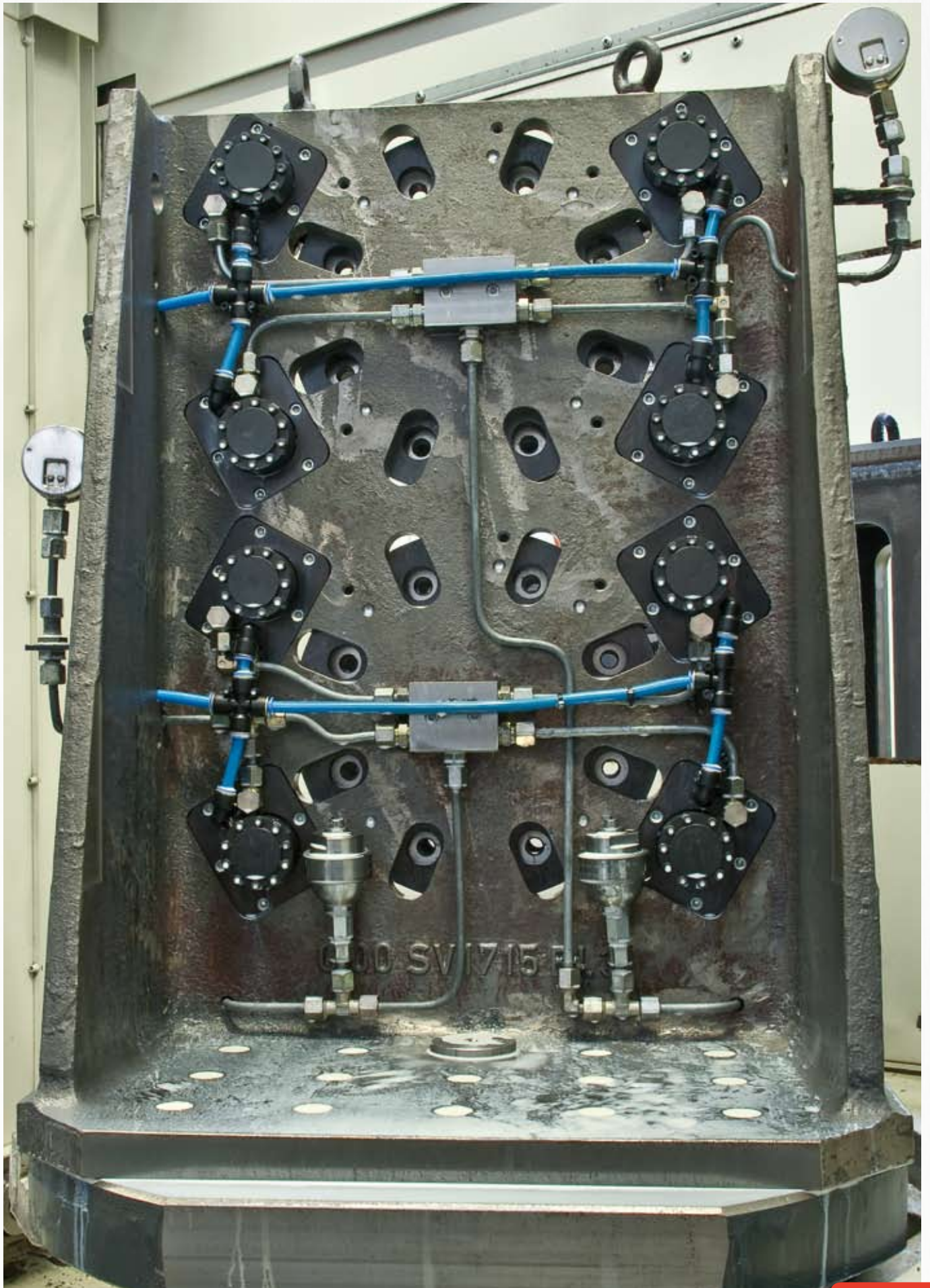

... BY ITEM NO.

Article no.	page	Article no.	page	Article no.	page	Article no.	page	Article no.	page
DIN 70852	38	No. 6911A-07-01	15, 172	No. 6935	36	No. 6954	225	No. 6972GR	133
DIN 7603	197	No. 6916-04	176	No. 6936	58	No. 6958A-16	98, 100	No. 6972W	133
DIN 908	197	No. 6916-05/06	176	No. 6936D	59	No. 6958A-20	101	No. 6973	134
No. 6380	203	No. 6916-07	176	No. 6940	200	No. 6958A-25	102	No. 6977	132
No. 6380D	203	No. 6916-08	176	No. 6941K	152	No. 6958A-32	103	No. 6981E-xx-G1/4	192
No. 6380WZ	204	No. 6916-09	177	No. 6941R	154	No. 6958AT	104	No. 6981G-xx-G1/4	193
No. 6383ZUK	201	No. 6916-10	177	No. 6941S	154	No. 6958AU	104	No. 6981-xx-G1/4	192
No. 6383ZUS	201	No. 6916-11	177	No. 6942K	156	No. 6958Ax-16	100	No. 6982-***	174, 175
No. 6387	204	No. 6916-12	83	No. 6942R	157	No. 6958Ax-20	101	No. 6982-02-01	174
No. 6540FX	63	No. 6917-1	160	No. 6942S	157	No. 6958Ax-25	102	No. 6982-05-01	175
No. 6540GX	62	No. 6917A-1	160	No. 6944GH	158	No. 6958Ax-32	103	No. 6982E	173
No. 6540KX	62	No. 6917E	163	No. 6945-02-04	230	No. 6958DR	109	No. 6982E-01-L	173
No. 6540SX	63	No. 6917F	162	No. 6945-11-***	222-224	No. 6958DT	107	No. 6983	196
No. 6540VX	63	No. 6917R	161	No. 6945-11-***	222	No. 6958DU	106	No. 6984-30	194
No. 6901	10	No. 6918	164, 165	No. 6945-11-***-10	224	No. 6958D-xx-04	109	No. 6985	195
No. 6902	11	No. 6918-10	165	No. 6945-15-10	230	No. 6958S-16	98, 100	No. 6985K	195
No. 6903	12	No. 6918-80-10	166	No. 6945-22-02	220	No. 6958S-20	101	No. 6985R	195
No. 6904-20	13	No. 6919-2	188	No. 6945-22-03	220	No. 6958S-25	102	No. 6988	196
No. 6904-25	14	No. 6919-20	190	No. 6945-22-04	218	No. 6958S-32	103	No. 6989M	178
No. 6904-50	15	No. 6919-25	191	No. 6945-22-06	219	No. 6958Sx-16	98	No. 6989N	179
No. 6904-52	15	No. 6919-30	191	No. 6945-22-07	219	No. 6959-**-10	115	No. 6990	196
No. 6904-54	15	No. 6919S	189	No. 6945-22-08	220	No. 6959C	110	No. 6990MK/SK	196
No. 6904-59	15	No. 6920	31	No. 6945-22-20	215-217	No. 6959CR-xx-04	112	No. 6991-01	180
No. 6904-90	15	No. 6920D	33	No. 6945-28-***	229	No. 6959C-xx-15-01	113	No. 6991-02	180
No. 6906	16, 20	No. 6920G	32	No. 6946	228	No. 6959C-xx-30	112	No. 6991-x0	182
No. 6906B-2-1	26	No. 6921	34	No. 6949	150	No. 6959KL	114	No. 6991-x1	183
No. 6906B-3-2	26	No. 6921S	35	No. 6951	81, 82	No. 6959KL-xx-30	116	No. 6992H-11	184
No. 6906BS-1	26	No. 6924	38	No. 6951F	79	No. 6959KR-xx-04	116	No. 6992H-21	186
No. 6906BS-2	26	No. 6925	39	No. 6951FN	88, 89	No. 6960C	120	No. 6993	197
No. 6906BS-3	26	No. 6925D	40	No. 6951FZ	70	No. 6961F/L	138	No. 6994	198
No. 6906BS-4	26	No. 6926	52	No. 6951FZN	71	No. 6962F/L	139	No. 6994	199
No. 6906BZH-2	27	No. 6926	53	No. 6951G	80	No. 6964F	140, 143	No. 6996	197
No. 6906P	208, 210	No. 6926D	54, 55	No. 6951GN	90, 91	No. 6964H	142, 145	No. 6997	197
No. 6906PB-4-4	213	No. 6926Z	61	No. 6951GZ	72	No. 6964H-xx-20	146	No. 7110DF-**xM**	200
No. 6906PB-4-5	213	No. 6927B	66	No. 6951GZN	73	No. 6964L	141, 144	No. 7110DH-**xM**	200
No. 6906PB-6-4	213	No. 6929	43	No. 6951K	78	No. 6965	147	No. 7110DI-**xM**	200
No. 6906PBS-1-1	213	No. 6929-03	42	No. 6951KN	86, 87	No. 6970-***	124	No. 7110DK-**xM**	200
No. 6910-06-01/02	170	No. 6930	44	No. 6951KZ	68	No. 6970-**-***	125	No. 7110DM-**xM**	200
No. 6910-06-04/05	171	No. 6930D	45	No. 6951KZN	69	No. 6970D	126, 127	No. 908G	197
No. 6910-10/11	167	No. 6932	46	No. 6951N	92, 93	No. 6972D	131	No. 908S	197
No. 6910A-05	167	No. 6933	47	No. 6951WN	82, 94	No. 6972F	130		
No. 6910A-07-02	172	No. 6934	48	No. 6952E	77	No. 6972G	133		

... BY ORDER NO.

Order no.	page	Order no.	page	Order no.	page	Order no.	page	Order no.	page
6163	229	61267	224	62885	176	63842	38	66530	68
9613	225	61275	224	62901	176	63859	38	66548	70
60004	47	61283	224	62968	176	63867	38	66555	68
60012	47	61291	224	62984	176	63875	38	66563	70
60020	47	61309	224	62992	177	63883	38	66571	68
60038	47	61382	230	63008	177	63891	38	66589	70
60046	43	61390	229	63016	31	63909	38	66597	68
60053	43	61408	219	63024	38	63917	38	66605	72
60061	43	61416	222	63032	32	63925	38	66613	72
60079	43	61424	222	63057	31	63933	38	66621	141
60087	43	61432	222	63073	32	63966	192	66647	120
60095	43	61440	223	63099	38	63974	38	66654	120
60103	43	61457	223	63115	38	63990	223	66662	120
60111	42	61465	223	63131	38	64006	222	66670	72
60129	44	61473	224	63149	34	64014	200	66688	141
60137	44	61481	224	63156	38	64022	200	66696	72
60145	44	61499	224	63164	38	64030	200	66704	141
60152	44	61622	217	63180	38	64048	200	66712	72
60160	44	61630	216	63198	195	64055	200	66720	145
60178	46	61663	213	63206	195	64063	200	66738	72
60186	46	61671	230	63214	195	64071	200	66746	142
60194	46	61689	216	63222	195	64089	224	66787	134
60202	46	61697	217	63230	195	64998	31	66795	72
60210	46	61705	219	63248	195	65003	31	66803	134
60285	223	61713	220	63354	52	65011	31	66852	140
60293	124	61861	87	63362	52	65052	139	66878	140
60301	124	61879	92	63370	52	65060	139	66894	140
60319	124	61887	87	63388	52	65078	139	66910	140
60327	223	61895	26	63396	52	65086	139	66928	72
60335	167	61903	87	63404	52	65094	139	66936	141
60376	124	61929	87	63412	52	65102	139	66944	71
60384	124	61937	11	63420	52	65250	138	66951	130
60392	213	61945	11	63438	52	65268	138	66969	130
60418	124	62034	54	63446	52	65276	138	66977	130
60426	124	62042	54	63453	52	65284	138	66985	130
60434	124	62067	55	63461	52	65292	138	67009	133
60475	223	62091	55	63479	52	65300	138	67017	133
60491	176	62117	54	63487	52	65318	32	67025	133
60517	164	62133	54	63503	224	65326	177	67165	133
60525	124	62158	55	63511	53	65334	32	67173	133
60616	124	62166	55	63529	53	65359	32	67181	133
60715	124	62174	54	63537	53	65375	165	67256	133
60723	124	62182	54	63545	53	65391	171	67264	133
60731	124	62190	55	63552	53	65417	225	67272	133
60772	26	62208	55	63560	53	65433	225	67322	133
60780	174	62224	88	63578	53	65458	225	67330	133
60798	125	62257	54	63586	53	65474	225	67348	133
60814	125	62323	54	63594	53	65490	225	67371	132
60822	125	62372	55	63602	53	65508	196	67421	132
60830	125	62380	55	63610	53	65524	196	67512	132
60848	92	62398	54	63628	53	65805	91	67520	132
60855	93	62406	54	63636	53	65870	73	67538	33
60863	93	62455	55	63644	53	65888	86	67546	33
61077	220	62463	55	63651	124	65896	86	67595	33
61085	215	62554	54	63669	125	65912	87	67603	33
61093	220	62562	54	63677	124	65920	87	67611	33
61101	218	62570	55	63685	125	65987	88	67629	33
61150	230	62588	55	63693	124	65995	69	67637	189
61168	188	62596	54	63701	125	66100	164	67645	189
61176	47	62604	54	63719	124	66118	26	67801	39
61184	222	62653	55	63727	125	66126	26	67819	10
61192	222	62786	55	63768	34	66290	89	67827	39
61200	222	62794	33	63784	38	66332	89	67835	10
61218	223	62836	33	63792	38	66480	70	67843	40
61226	223	62844	33	63800	38	66498	68	67850	36
61234	223	62851	33	63818	38	66506	70	67868	40
61242	223	62869	33	63826	38	66514	68	67876	36
61259	224	62877	33	63834	38	66522	70	67884	40

... BY ORDER NO. (CONTINUED)

Order no.	page	Order no.	page	Order no.	page	Order no.	page	Order no.	page
67892	36	68619	80	69492	89	175323	198	320333	147
67900	40	68627	80	69500	92	176040	174	320341	147
67918	36	68635	80	69526	93	176214	174	320358	147
67926	40	68650	80	69609	197	176693	197	320366	165
67934	36	68676	80	69625	197	176701	197	320457	82
67942	40	68692	80	69641	197	176719	197	320465	82
67959	36	68718	80	69666	197	179952	197	320473	94
67967	40	68726	78	69757	90	181214	167	320481	94
67975	39	68734	80	69765	91	184150	198	320499	94
67983	40	68742	78	69773	90	253823	213	320507	45
67991	39	68759	80	69781	91	255687	222	320515	45
68007	40	68767	78	69815	197	255752	222	320523	45
68015	39	68775	78	69823	197	258236	15	320531	45
68023	58	68791	78	69963	90	259168	170	320549	45
68031	39	68817	196	76059	200	259226	170	320556	45
68049	58	68825	196	77446	200	259242	15	320614	131
68056	58	68833	78	77453	200	267062	38	320622	115
68064	66	68858	78	77743	200	267427	15	320630	115
68072	58	68874	78	77750	200	271031	15	320648	196
68080	66	68890	78	83931	200	271031	15	320655	196
68098	58	68916	78	83949	200	275198	12	320689	199
68106	66	68932	78	86223	200	276824	171	320705	199
68114	58	68957	78	86637	200	276881	175	320721	199
68122	66	68973	81	86652	200	283184	54	320747	199
68130	58	68999	81	87858	200	288225	165	320774	199
68155	59	69005	35	87866	200	291526	12	320762	199
68171	59	69013	196	87874	200	294637	54	320788	199
68197	59	69021	196	87882	200	295246	55	320804	199
68213	59	69039	196	87908	200	295360	54	320820	199
68221	79	69047	35	87916	200	295410	54	320846	199
68239	59	69054	196	87924	200	295436	54	320861	199
68247	79	69062	196	87924	200	295451	54	320887	133
68254	59	69070	81	110692	222	295477	54	320903	133
68262	79	69088	180	110700	222	295535	54	321620	133
68270	59	69104	180	112714	198	295550	54	321646	115
68288	79	69112	81	112961	198	295592	54	321695	114
68296	59	69120	91	114298	167	295618	55	321711	114
68304	79	69138	81	114405	130, 131	295626	55	321901	193
68312	48	69146	92	116418	198	295634	55	321927	193
68320	79	69153	81	122903	198	295642	55	321968	193
68338	48	69161	93	126326	213	295667	55	322032	114
68346	79	69179	160	131631	198	295675	55	322040	114
68353	48	69211	160	136291	175	295683	55	322057	114
68361	79	69229	81	153288	197	295691	55	322065	15
68379	48	69245	81	156067	130	295709	55	322065	172
68387	79	69252	82	160093	197	313361	199	322073	172
68395	48	69260	81	160184	198	320002	190	322214	16
68403	79	69278	82	160192	198	320028	191	322230	16
68411	79	69294	82	160200	198	320044	191	322248	98
68429	80	69302	197	160358	198	320051	192	322255	98
68437	79	69328	197	160366	198	320069	192	322404	100
68445	80	69336	69	161414	196	320077	192	322420	100
68452	80	69344	197	164962	179	320085	192	322438	98
68460	80	69351	71	164970	178	320093	192	322446	101
68478	80	69369	86	164988	179	320135	164	322453	98
68486	80	69377	73	164996	178	320143	164	322461	101
68502	80	69385	86	165092	143	320150	131	322487	102
68510	195	69393	197	165100	143	320168	131	322495	101
68528	195	69401	87	165167	144	320184	12	322503	102
68536	195	69419	197	165183	144	320192	12	322511	101
68544	195	69427	87	165225	145	320200	12	322529	103
68551	195	69435	13	165241	145	320218	98	322537	101
68569	195	69443	88	168575	196	320234	98	322545	103
68577	195	69450	14	170258	198	320242	98	322552	101
68585	195	69468	88	170266	198	320259	98	322560	104
68593	195	69476	90	170308	198	320267	98	322586	104
68601	195	69484	89	170316	198	320275	98	322594	101
				174177	195	320283	98	322602	104

... BY ORDER NO. (CONTINUED)

Order no.	page	Order no.	page	Order no.	page	Order no.	page	Order no.	page
322610	101	323667	192	325514	62	326611	83	373761	201
322628	104	323683	192, 193	325522	112	326629	152	373779	204
322636	101	323709	192, 193	325530	62	326637	150	373787	204
322651	101	323725	192, 193	325548	112	326645	152	373795	204
322693	102	324178	100	325555	62	326652	150	373803	204
322719	102	324186	100	325563	110	326660	152	373811	204
322735	102	324194	100	325571	62	326678	161	373829	204
322750	102	324384	126	325597	62	326686	163	373837	204
322792	102	324392	126	325605	63	326702	208	373845	204
322818	102	324400	126	325613	63	326728	210	400267	116
322834	102	324418	100	325621	63	326785	162	400283	116
322859	102	324426	27	325639	63	334185	182	400309	116
322867	156	324434	100	325647	63	343632	197	400325	116
322883	156	324459	100	325654	63	373001	203	401299	116
322891	103	324475	100	325878	142	373019	203	402610	175
322909	156	324483	100	325886	77	373027	203	408401	165
322917	103	324491	178	325894	77	373035	203	409508	115
322925	156	324509	179	325902	16	373043	203	445536	183
322933	103	324517	178	325910	16	373050	203	452060	12
322941	156	324525	179	325928	16	373068	203	492256	175
322958	103	324533	184	325936	16	373076	203	492330	163
322990	103	324541	184	325944	16	373084	203	497636	175
323014	103	324558	184	325951	16	373092	203	498709	173
323030	103	324566	186	325969	16	373100	203		
323055	103	324574	186	325977	16	373118	203		
323089	104	324582	186	325985	20	373126	203		
323105	104	324590	20	325993	20	373134	203		
323121	104	324616	20	326009	20	373142	203		
323147	104	324632	113	326017	20	373159	203		
323170	157	324640	113	326025	20	373167	203		
323196	157	324657	110	326033	20	373175	203		
323212	157	324723	26	326041	20	373183	203		
323238	157	324905	110	326058	20	373191	203		
323246	154	324996	112	326215	109	373209	203		
323253	157	325019	110	326231	107	373217	203		
323261	154	325035	112	326256	109	373225	203		
323279	157	325068	164	326272	106	373233	203		
323287	154	325118	165	326280	166	373241	203		
323295	157	325134	228	326298	107	373258	203		
323303	154	325142	228	326306	164	373266	203		
323311	157	325159	228	326314	106	373274	203		
323329	154	325167	228	326322	109	373282	203		
323337	157	325175	228	326348	109	373290	203		
323345	154	325183	228	326363	15	373308	204		
323352	157	325191	228	326371	106	373316	204		
323360	154	325209	228	326389	197	373332	204		
323386	154	325217	194	326397	107	373340	204		
323394	26	325225	112	326405	161	373563	201		
323402	154	325233	112	326413	109	373571	201		
323410	126	325241	116	326421	161	373589	201		
323428	154	325266	116	326439	109	373597	201		
323436	126	325282	116	326447	173	373605	201		
323444	126	325290	113	326454	152	373613	201		
323451	182	325308	116	326462	163	373621	201		
323469	126	325324	116	326470	152	373639	201		
323477	182	325340	158	326488	163	373647	201		
323485	126	325365	158	326496	152	373654	201		
323493	183	325373	61	326504	162	373662	201		
323501	127	325399	61	326512	152	373670	201		
323519	183	325415	62	326520	146	373688	201		
323527	127	325431	62	326538	152	373696	201		
323543	127	325456	62	326546	146	373704	201		
323568	127	325464	112	326561	146	373712	201		
323584	127	325472	62	326579	83	373720	201		
323600	127	325480	113	326587	152	373738	201		
323626	192	325498	62	326595	158	373746	201		
323642	192	325506	112	326603	152	373753	201		

... IN ALPHABETICAL ORDER

0-9	page	D	page
1-circuit control switch (rotary switch)	26	Double-nipple	197
2/2-Way-Manual Seat Valve	167	Dummy connector	196
2-circuit control switch (rotary switch)	26		
3/2-Seat Valve	172	E	
3/2-Seat Valve	15	Eccentric clamping bolt	204
3/2-Way-Manual Seat Valve	167	Electronic pressure switch	173
3/3-Seat valve	172		
4/3-Seat Valve	15, 172	F	
A		Filter	192
Accessories	195-200	Filter with rectifier circuit	193
Accessories for Air-Hydraulic Pump	15	Flange Nut	38
Accessories for Hollow Rod Cylinder	33	Flange with pipe socket	175
Accessories for hydraulic clamping chains	61-63	Front Insertion Guide	220
Accessories for Pump units	26-27, 213		
Accumulator	189	G	
Adapter	199	Gauge	196
Adaptor Plate for Clamping Head	224		
Adjustable angular fitting	198	H	
Adjustable T-bolt fitting	198	Hand Pump	11
Air filter and pressure regulator	15	HELI-COIL thread insert	33
Air-Hydraulic Pump	13, 14	High Pressure Hose	195
AI Protection MK/SK	196	High Pressure Hose with steel-wire interlace	195
Angle Swivel Joint, 90° single passage	180	Holder for Clamping Head	222
Angular fitting	198, 199	Hollow Rod Cylinder	31-34
Angular fitting, adjustable	198	Hollow Rod Cylinder with internal thread	32, 36
Angular swivelling screw fitting	198, 199	Hollow Rod Cylinder with internal thread	36
Axial Swivel Joint, single passage	180	Hollow Rod Cylinder with mechanic locking	35
		Hook ends, hydraulic	61
		Hose fittings	197
B		Hydraulic Compensating Clamp	147
Ball-Valve	177	Hydraulic intensifier	12
Base for Clamping Head	223	Hydraulic Pull-Down Clamping Element, concentric	124
Block Cylinder	52-55, 58, 59	Hydraulic Pull-Down Clamping Element, eccentric	125
Built-In Cylinder	38-40	Hydraulic pull-down spring clamp, eccentric	126, 127
C		I	
Centering tensioner	201	Intensifier, hydraulic	12
Check valve, hydraulically pilot operated	176	Intermediate flange	197
Clamp arm out of aluminium for vertical clamps	98-103		
Clamp arm out of steel for vertical clamps	98-103, 109	L	
Clamping arm blank for link clamps	157	Lateral pressure pad	203
Clamping arm blank for swing clamps	154	Line Check Valve	176
Clamping arm for link clamps	157	Link Clamp	114
Clamping arm for swing clamps	154	Link clamp, integrated version	110
Clamping arm, blank for link clamps	112, 116	Link Clamp, Low pressure	156
Clamping arm, blank for vertical clamps	109	Low pressure Link Clamp	156
Clamping arm, standard for link clamps	112, 116	Low pressure Pump Unit	150
Clamping Bar, long	216, 217	Low pressure Support Element, cartridge type	158
Clamping Bar, short	215	Low pressure Swing Clamp	152
Clamping bolt, eccentric	204	Low-pressure clamping technology	149-158
Clamping Head	223		
Clamping Head, complete with base	222	M	
Clamping Jaws, serrated	133	Manifold	196
Clamping Jaws, soft	133	Manual Seat Valve, 2/2-Way and 3/2-Way	167
Clamping Jaws, with clamping edge	133	Multiple-Clamping System	135
Clamping Piston, complete	224, 230		
Clamping Stud	230	O	
Clamping Stud Holder, hydraulic	229	O-ring	115, 130, 131
Compensating clamps	147		
Connecting links with spring cotter pin	63		
Connecting Plate for reducing valve	160		
Connection Plate	167		
Connection Plate for Piston Pressure Switch	174		
Connector	196		
Control switches	26, 27, 213		
Counter catch for hydraulic clamping chains	62		
Coupling Plug	26		
Coupling Plug, 13-pin	213		
Coupling Unit for Pallet Decoupler Block	191		
Cross-pattern bolting	198, 199		

... IN ALPHABETICAL ORDER (CONTINUED)

P	page	S	page
Pallet Decoupler Block	188, 190	Support control, pneumatic	194
Piston Pressure Switch	174, 175	Support Element, base-flange-mounting	140-142
Pneumatic Support control	194	Support Element, block type	138
Pressure control seat valve	161-163	Support Element, cartridge type	139
Pressure generators	9-28, 208-212	Support Element, cartridge type, Low pressure	158
Pressure Reducing Valve	160	Support Element, threaded-type	143-145
Pressure Relief Valve	165	Surface-mounted block for link clamps	113
Pressure switch, electronic	173	Surface-mounted block for vertical clamps	104
Pressure switches	173-175	Surface-mounted housing	26
Protection, Alu, MK/SK	196	Swing Clamp Arm, double ended	82, 93
Protective elements for hydraulic clamping chains	63	Swing Clamp Arm, long	81, 93
Pull Cylinder, block type	66	Swing Clamp Arm, standard	81, 92
Pull-Down Clamp	134	Swing Clamp Arm, upreach	81, 92
Pull-Down Clamp, hydraulic	130, 131	Swing Clamp, base-flange-mounting	79, 88, 89
Pull-down clamping elements	124-131	Swing Clamp, Low pressure	152
Pull-Down Counter-Hold, mechanical	132	Swing clamp, threaded design	77
Pump unit	16-25, 208-212	Swing Clamp, thread-flange-mounting	80, 90, 91
Pump unit, Low pressure	150	Swing Clamp, top-flange-mounting	78, 86, 87
Push-Pull Cylinder, base-flange-mounting	70, 71	Swivel Clamping Strap, hydraulic	225
Push-Pull Cylinder, thread-flange-mounting	72, 73	Swivelling screw fitting, angular	198, 199
Push-Pull Cylinder, top-flange-mounting	68, 69		
		T	
Q		T-bolt fitting	198, 199
Quick Disconnect Coupler	196	T-bolt fitting, adjustable	198
		Thread insert	33
R		Threaded Check Valve	176
Rear Stop	220	Threaded Cylinder	45
Reduction piece	197	Threaded Cylinder bottom sealing	48
Remote Control Switch	213	Threaded Cylinder bottom sealing, piston rod with internal thread	44
Remote Control Switch with magnetic base	213	Threaded Cylinder bottom sealing, with spherical piston rod	43
Remote Control Switch with magnetic base and safety cover	213	Threaded Cylinder for tube connection, with spherical piston rod	42
Roller chain for hydraulic clamping chains	62	Threaded Cylinder with spherical piston rod	46
Rotary control switch	26	Threaded Cylinder, piston rod with internal thread	47
Rotary coupling	180-186	Threaded filter set spare parts	161, 192, 193
Round connector	173	Threaded plug	197
		Throttle/Check Valve	83
S		Throttle/Check Valve	177
Screw Pump	10	Toggle Clamp, hydraulic	120
Screw-in Coupling Mechanism	178	Tool clamping for presses	208-230
Screw-In Coupling Nipple	179	Tool for Lateral pressure pad	204
Screw-in fitting, straight	198, 199	T-swivelling bolt fitting	198, 199
Screw-in flange, straight	198, 199	Tube Fittings, heavy-duty	198
Screw-in nipple	197	Tube fittings, light duty	199
Screw-on fitting, straight	198	Two-hand safety operator panel	27
Seal Cu	197		
Seat Valve, 3/2-Way	15, 170, 171	U	
Seat Valve, 3/3-Way	172	Union nut with cutting ring	198, 199
Seat Valve, 4/3-Way	15, 172		
Sensor sub-assembly for link clamps	115	V	
Sequence Valve	164-166	Valves	160-172, 176-177
Set screw	200	Vent screw	197
Set screw, ball-shaped	200	Vertical Clamp	98-103, 106, 107
Set spare parts - Threaded filter	161		
Shuttle Valve	176	W	
Sleeve	196	Wall fitting, straight	198, 199
Spacer Bar	218-220	Wedge clamp	228
Special block cylinders	54, 55		
Splash protection	146		
Spring cotter pin	63		
Store Station for Coupling Unit	191		
Straight screw-in fitting	198, 199		
Straight screw-in flange	198, 199		
Straight screw-on fitting	198		
Straight wall fitting	198, 199		

These conditions of sale apply to business conducted with companies, legal entities in the public sector, and legal entities with special budget in the public sector. Our deliveries and services are carried out exclusively on the basis of the conditions stated below. Deviating purchasing conditions of the buyer will not become part of the contract, not even through acceptance of the order, unless we have expressly accepted them.

1. Offer and entering into a contract

The basis of our delivery contracts is the latest edition of our catalogue. Orders are not considered as accepted until they have been confirmed by us in writing. When goods are supplied from stock and, for organisational reasons, you receive no separate confirmation, the invoice has the additional function of confirming the order. Details of dimensions and weights, and illustrations, drawings and data are not binding and may be changed by us at any time. Deviations cannot be excluded.

2. Prices

Prices are quoted in EUR ex-works excluding turnover tax, packing, freight, carriage, and insurance. Unless otherwise agreed, our list prices on the day of delivery apply. In order to cover our costs, orders under EUR 50.- net value are subject to a small order surcharge of EUR 10.-.

3. Delivery

Delivery delays are quoted to the best of our knowledge but without guarantee. Agreed delivery delays begin on the day we accept the order and refer to the completion of the goods in our works.

4. Transfer of risk

Risks are transferred to you when the goods are passed to a specific person, company, or organisation that is charged with the execution of carriage of the goods. This applies also to partial deliveries and when we have accepted the costs of carriage, delivery or erection. The risks are also transferred to you when you have defaulted on acceptance.

5. Dispatch

Goods are supplied ex-works. Dispatch is at your cost and risk. Scheduled, FOB, and CIF deliveries are also at your risk. In the absence of specific instructions concerning dispatch, we will arrange same as we think fit, but without accepting any responsibility for choosing the cheapest or most suitable method of dispatch. We make a handling charge of EUR 5.- if goods are sent at your request to a third party. You accept that your order can be supplied in partial deliveries insofar as this is reasonable.

6. Reservation of proprietary rights

Goods delivered remain our property until payment of all claims has been received in full or until redemption of cheques given in payment. The cancellation of individual positions in an open invoice and the drawing of a balance and its acceptance do not affect proprietary rights. You have the right to dispose of the goods as a normal commercial transaction, but you are forbidden to pawn, mortgage, or transfer ownership of them in settlement of a debt or debts. You surrender to us herewith your right to payment for goods for which we reserve our proprietary rights. You have the right to collect these payments as long as you meet your obligations to us. If we request it, you are obliged to name the third party and we have the right to publish this information and the transfer of rights.

7. Cancellation rights due to late payment or insolvency

If you do not pay for the goods by the time payment is due, and if you have not paid after expiry of a reasonable time limit set by us, we have the right to withdraw from the contract and demand the return of goods already supplied. Rights under § 323 BGB (BGB = German civil law code) remain otherwise unaffected. Application for the opening of insolvency proceedings gives us the right to withdraw from the contract and demand the immediate return of goods supplied before the bankruptcy court orders protective measures.

8. Packaging

Packages comply with the German packaging regulations (WO). Disposable packaging is charged at cost. The packaging is not returnable.

9. Tooling costs

In the absence of any agreement to the contrary, tooling made for the execution of an order remains our property in all cases. This applies even if we have made a charge for a proportion of the tooling costs.

10. Payment

Our invoices are payable net within 30 days of the date of the invoice, or with 2% discount if paid within 10 days. Invoices below EUR 50.- are payable immediately without discount. Our credit notes and your charges on us reduce the amount subject to discount. Late payment entitles us to interest at the rate the bank charges us for a current account overdraft but at least 8 percent above the current base rate of the European Central Bank. If payment is overdue, we are entitled, after giving you notice in writing, to cease fulfilling our obligations under the contract until payment is received.

11. Offsetting exclusion

You can only offset payments with legally-established or unopposed counter claims.

12. Guarantee

If you come to an agreement with us on properties of the goods, we include this agreement in our technical specifications. If we have to supply to your drawings, specifications, samples, etc., you accept the risk associated with suitability for the intended purpose. The point in time at which risk is transferred is decisive for the contractual condition of the goods. The deterioration of parts subject to wear in the course of normal use does not constitute a defect. If the goods supplied are defective, we will – at our choice and within a reasonable time limit set by you – supply a replacement or repair the goods. If such repair or replacement is not satisfactory, you have the right to reduce the price or withdraw from the contract. Any further guarantee claims are excluded. Recognisable defects must be notified at the latest within 10 days of receipt and defects that are not recognisable must be notified as soon as they are discovered. The guarantee period is 24 months and starts with dispatch of the goods from our works.

13. Hindered or impossible performance

If we are prevented from meeting our obligation by some unforeseeable event (e.g. disruption of our plant, or delay in the delivery of important raw materials), which, in spite of taking all reasonable care appropriate to the circumstances of the case, we have been unable to avert, and it has become impossible to execute the delivery or service punctually, the delivery delay will be extended to an appropriate extent.

14. Liability

Except in the case of injury to life or limb, or damage to health caused by our breach of duty, we are only liable in the event of intent or culpable negligence on our part.

15. Customer specials

Orders for customer specials must be in writing and include binding details of execution, quantities etc. For technical reasons we reserve the right to supply 10% more or less than the quantity specified. If technical changes or cancellation are required, the costs incurred will be charged to the customer.

16. Deliveries of samples and return of goods

Samples will be charged. When goods have been sent for testing or as samples, we will credit you with the additional price against subsequent orders, as long as the net contract value is at least EUR 125.-. The return of goods is only possible with prior agreement. Customer specials may not be returned. For goods returned for reasons outside our responsibility (e.g. wrongly ordered), we charge 10% of the value of the goods but at least EUR 7.50, to cover administration costs.

17. Place of fulfilment, court of jurisdiction

The place of fulfilment for all obligations arising from this contract is D-70707 Fellbach. The court of jurisdiction for any legal dispute arising from this contract is D-71332 Waiblingen. (All disputes that arise from this contract or about its validity will be decided by a court of arbitration according to the Arbitration Rules of the German Committee for Arbitration Courts/Settlement and Arbitration Procedure of the International Chamber of Commerce. Such decisions will be final and normal legal procedures are excluded.) German law applies (BGB and HGB = civil and commercial codes). The application of UN purchasing law (CISG) is excluded.

18. Validity clause

If individual conditions should be found to be not legally valid, the remaining conditions continue to apply. The invalid conditions will be replaced by conditions which fulfil as closely as possible the commercial intent of the contract with reasonable consideration of the interests of both parties. With the publication of these Conditions for Sales, Deliveries and Payment, all previous versions become invalid. This does not apply to contracts agreed before publication.

...just copy
and mail or fax

REQUEST FOR CATALOGUES:

- | | |
|--|--|
| <input type="checkbox"/> Locks for doors and gates | <input type="checkbox"/> Clamping and fixture systems |
| <input type="checkbox"/> Hand tools | <input type="checkbox"/> Magnetic clamping technology |
| <input type="checkbox"/> Toggle clamps, manual and pneumatic | <input type="checkbox"/> Zero-Point Systems |
| <input type="checkbox"/> Mechanical clamping elements | <input type="checkbox"/> Clamping and fixture system for automated welding |
| <input type="checkbox"/> Hydraulic clamping systems | <input type="checkbox"/> Positioning system for laser marking |

Company/Address (please don't forget your phone no.)

ANDREAS MAIER
GmbH & Co. KG
Schloss- und
Werkzeugfabrik
Postfach 1760

70707 FELLBACH

responsible



HOW DO I ORDER?



AMF e-Business offers you new possibilities! Many of our customers have been ordering AMF products electronically for several years now. Currently, for more than 30% of our sales, orders are placed electronically and processed online. In the sidebar you will find the various ordering options with which you too can profit from the advantages that AMF e-Business offers.

E-COMMERCE AT AMF - THE AMF ONLINE SHOP

In our new AMF Online Shop, AMF offers you the best conditions for your Internet buying. Its basis today is a media-neutral database from which our Online Shop and related print media are generated fully automatically. In this way you always have immediate access to the latest products and revisions.

Using the direct online connection to the AMF inventory control system, you can check the availability and delivery of the goods you need, and check the current status of your order at any time.

If you are a registered customer, you can log in to access your specific, individual prices and order data.

1. Use the „Products“ menu item to go to our Online Shop.
2. Register without obligation; your access data will be sent to you automatically by e-mail.
3. Study our range of products and select those you need on the individual product pages, or use „Rapid registration“ to put them straight in the trolley.
4. Go to „Prices and availability“ to check when a product can be supplied.
5. When you order: send off your order, and you are 98% certain to receive your goods on the next working day (within Germany).
6. The entire system is supplemented and enhanced by integration of the CAD data for AMF products. These are available to our customers free of charge, in over 60 CAD formats, direct from the AMF Shop.

Go online with us – test our website and register so that you have all these advantages. We look forward to your visit ...

IN THE ONLINE SHOP:

Register at www.amf.de/ products and order at the click of a mouse - simple and uncomplicated.

USING EDIFACT:

you can order direct from your inventory control system. If desired you can also receive the delivery note and invoice via EDIFACT.

IN E-MAIL FORMAT:

you send us the necessary data for your order. Please ask us how it must be formatted.

BY TELEPHONE:

just as before, all information is available from our service staff

+49 711 5766-112



ECONOMICAL, PRECISE, QUICK - THE AMF ZERO-POINT SYSTEM

By using modern AMF zero-point systems, you optimize fixture and workpiece changeover in your production, correspondingly reducing set-up times on the machine and so save money!

The benefits of zero-point clamping technology are obvious:

- > Increase in machine run-time
- > Very fast workpiece or fixture changeover
- > High repeatability
- > A uniform interface for all machines
- > Positioning and clamping in a single step





> The clamping nipple in our zero-point system is the interface between the machine table and the workpiece or fixture. It ensures exact positioning and secure clamping. The resulting work forces are transferred through the clamping nipple to the clamping module.

Our complete zero point clamping programme can be found in our catalogue „Zero-Point-Systems“.

> The precisely manufactured clamping modules of the AMF Zero-Point System ensure a secure and firm hold of the workpiece or fixture to be clamped. With their high pull-in, closing and holding forces, they are suitable for every application.





DEMONSTRATION AND ADVICE:

Do you have a clamping problem? Let us show you, without obligation, how your problem can be solved on the basis of our comprehensive range of hydraulic products, for example by making a practical trial clamping.

TRAINING:

In our own Training and Demonstration Room, our qualified application technicians will show you the variety, advantages, and special features of AMF Clamping Hydraulics in detail.

INSTRUCTION AND SUPPORT:

Not only in the planning phase, but also before and after sales our application engineers will support you.

OUR OBJECTIVE - YOUR ADVANTAGE:

Drastic reduction of setting-up and part-changing times, and thus clear cost savings through competent, well-founded advice, demonstration, and information.

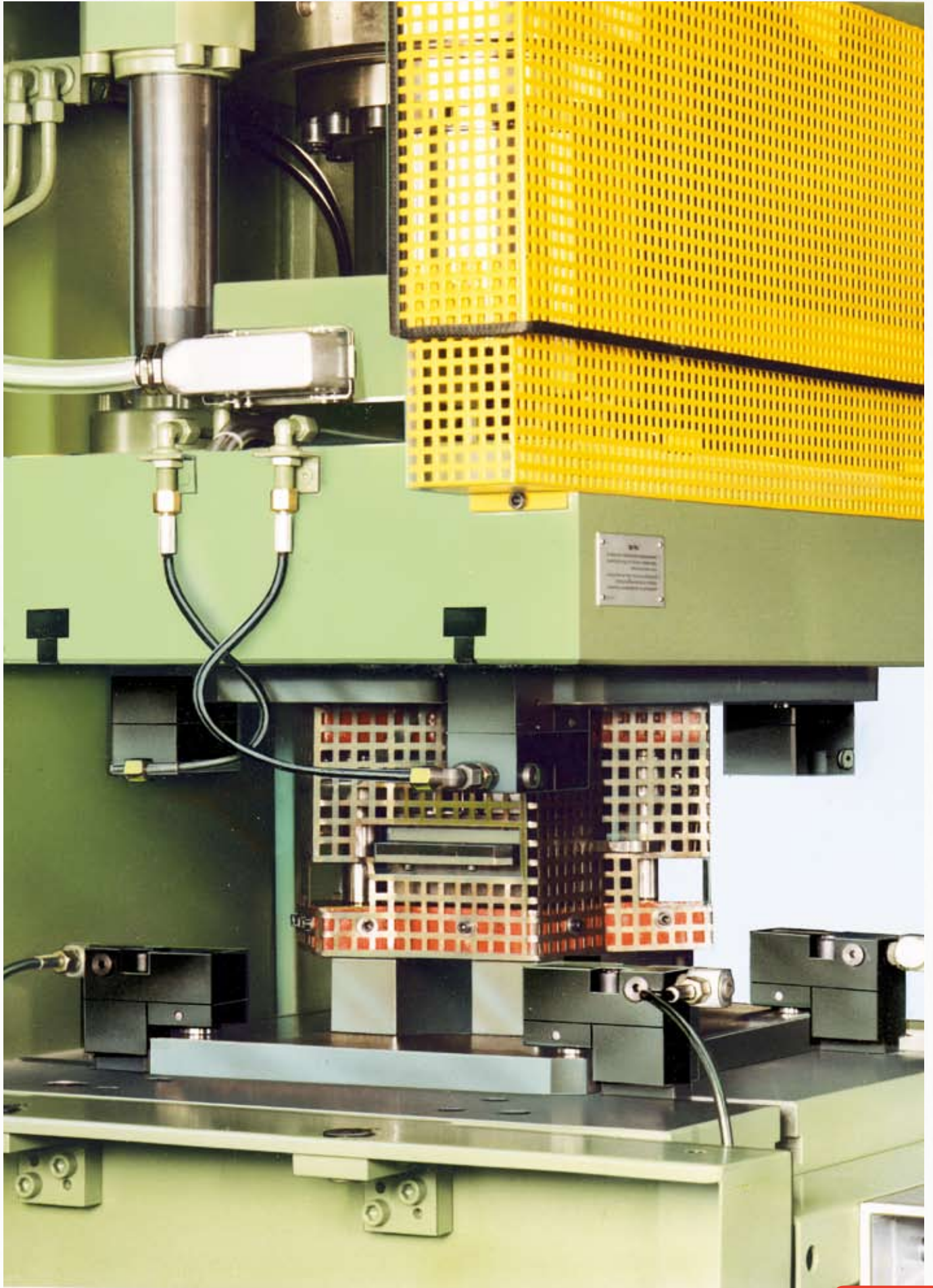

YOUR IDEAS WORKSHOP.



CLAMPING. SCREWING. LOCKING. Plus Service Guarantee

We are your partner in innovation for solutions to mechanical, pneumatic, and hydraulic clamping problems.

- ▶ Reduction of set-up times
- ▶ Advice
- ▶ Automation solutions
- ▶ CAD data in over 60 formats with kinematics and collision functions

Just test us!

With AMF you are always a step ahead! AMF CAD data are transmitted to sub-assemblies with active links. This feature can be exploited by the CAD systems Solid Works, Unigraphics, Inventor and Catia V5.

Further advantages:

- ▶ Complete transmission of the structure tree, including all accessories, with all CAD systems!
- ▶ When parts lists are generated, the article designations from the structure tree are automatically incorporated.
- ▶ Ordering procedures can thus be initiated directly.
- ▶ In addition, sample functions are transmitted which
 - a) increase computer speed and
 - b) simplify the job of the tool designer.
- ▶ When they are not needed, the sample functions can be suppressed





TOGGLE CLAMPS,
MANUAL AND PNEUMATIC



HAND TOOLS



MAGNETIC CLAMPING
TECHNOLOGY



HYDRAULIC CLAMPING
SYSTEMS



MECHANICAL CLAMPING
ELEMENTS



ZERO-POINT-SYSTEMS



CLAMPING AND FIXTURE SYSTEM
FOR AUTOMATED WELDING



LOCKS FOR DOORS
AND GATES



CLAMPING. SCREWING. LOCKING.

ANDREAS MAIER GmbH & Co. KG

Waiblinger Straße 116 · D-70734 Fellbach
Postfach 1760 · D-70707 Fellbach
Phone: +49 711 5766-0
Fax: +49 711 575725
E-Mail: amf@amf.de · Mobile: amf.mobi
Internet: www.amf.de

Sales

Phone: +49 711 5766-112
Fax: +49 711 575725
E-Mail: export@amf.de

Catalogue order no. 446435 · € 3,60